

Wingspan : 1270mm (50in)
Length : 1050mm (41.3in)
Flying Weight : 1450g (51.2oz)
Wing Area : 25dm²
Wing Load : 41g/dm²
Radio System : 4 Ch TX and 7 Ch RX
Power : Brushless System
Battery : LIPO, 2200 mAh, 14.8V

DIRECTIONS FOR ASSEMBLY AND ADJUSTMENT

SPARE PART LIST:

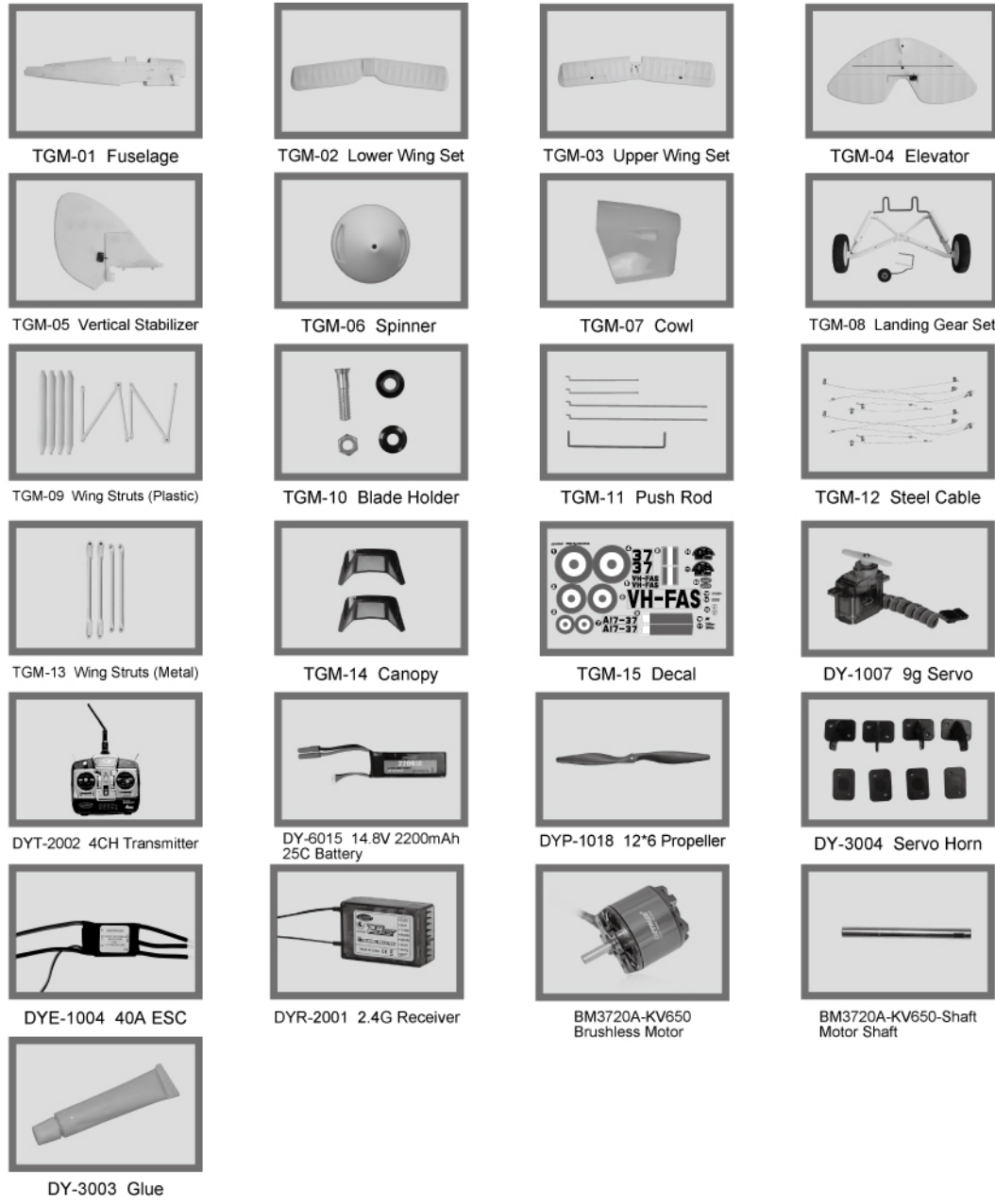

Control Throw Setting Suggestion

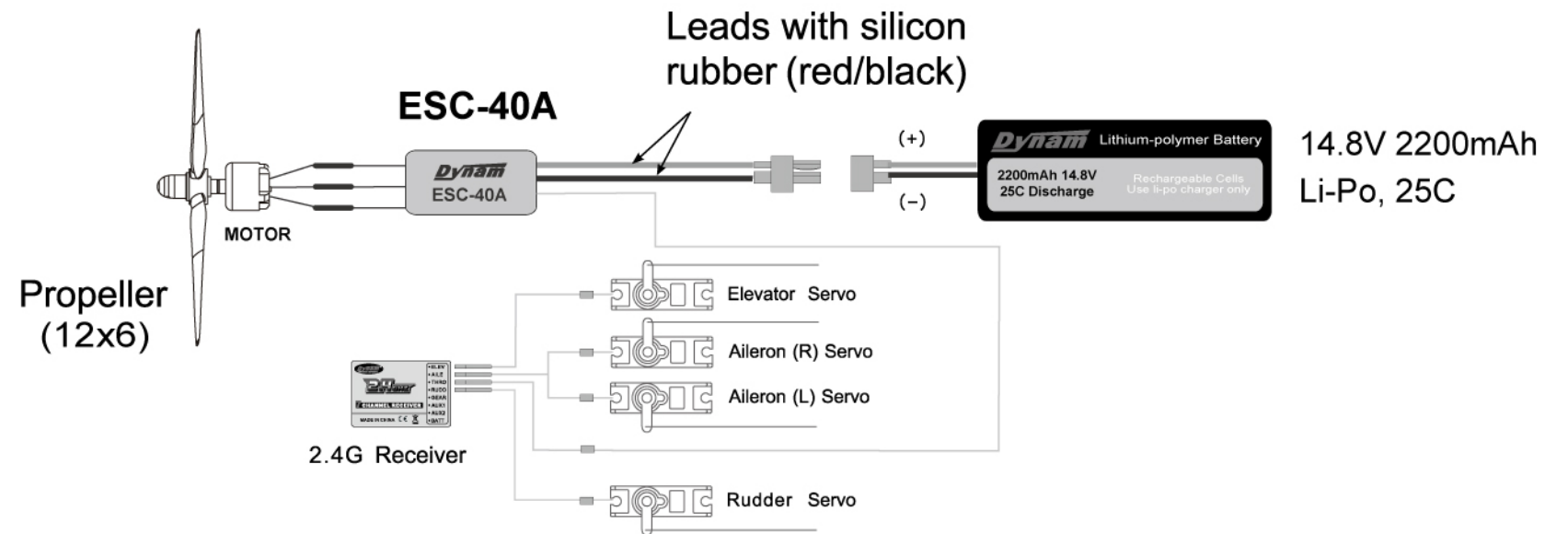
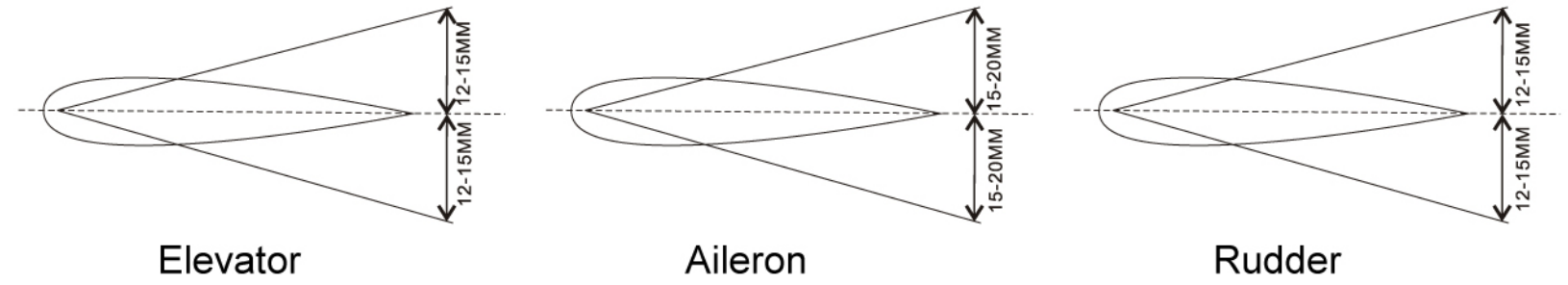

ASSEMBLY:

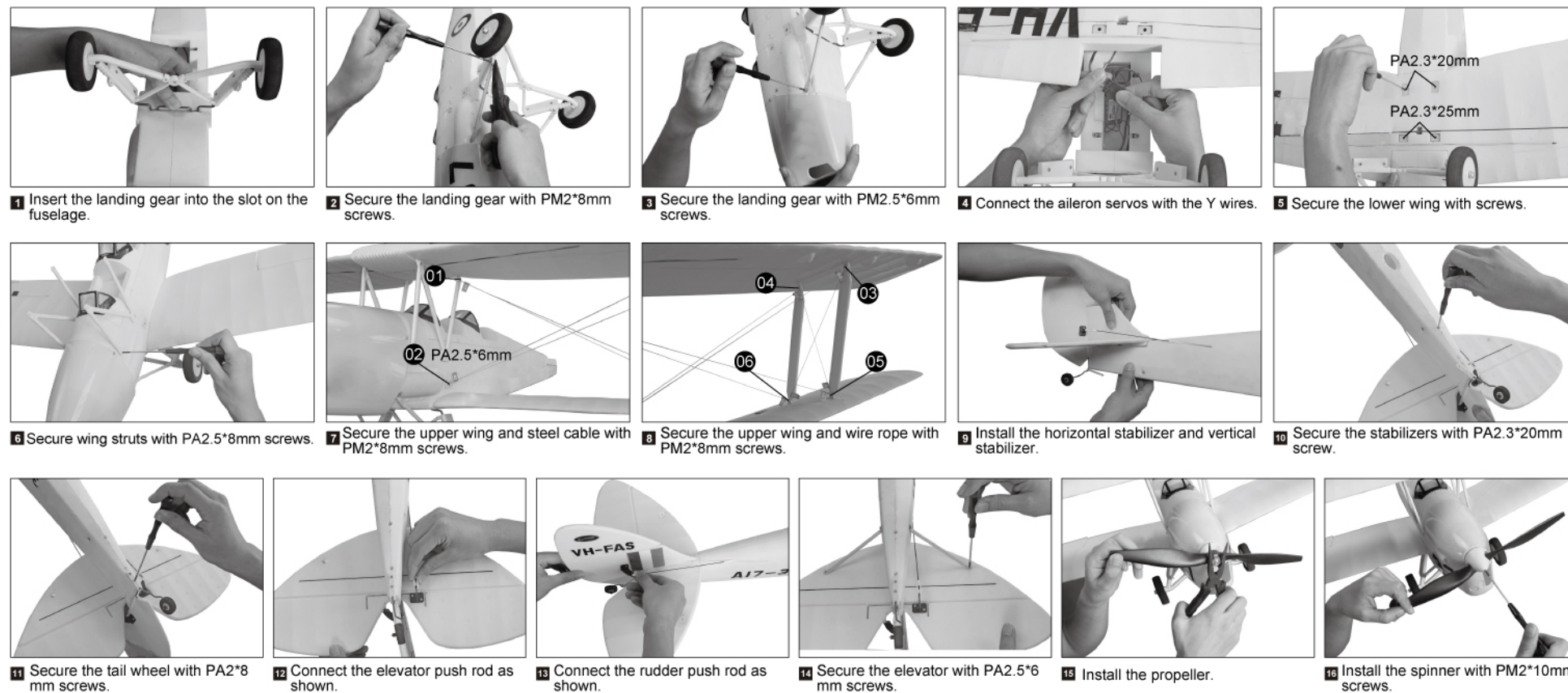

CENTER OF GRAVITY(C.G.)

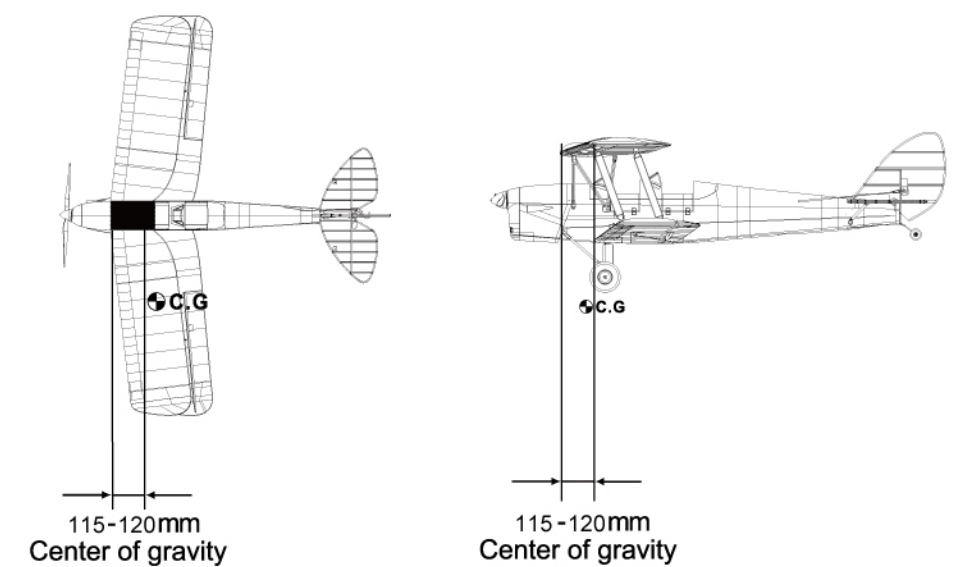

DECAL:

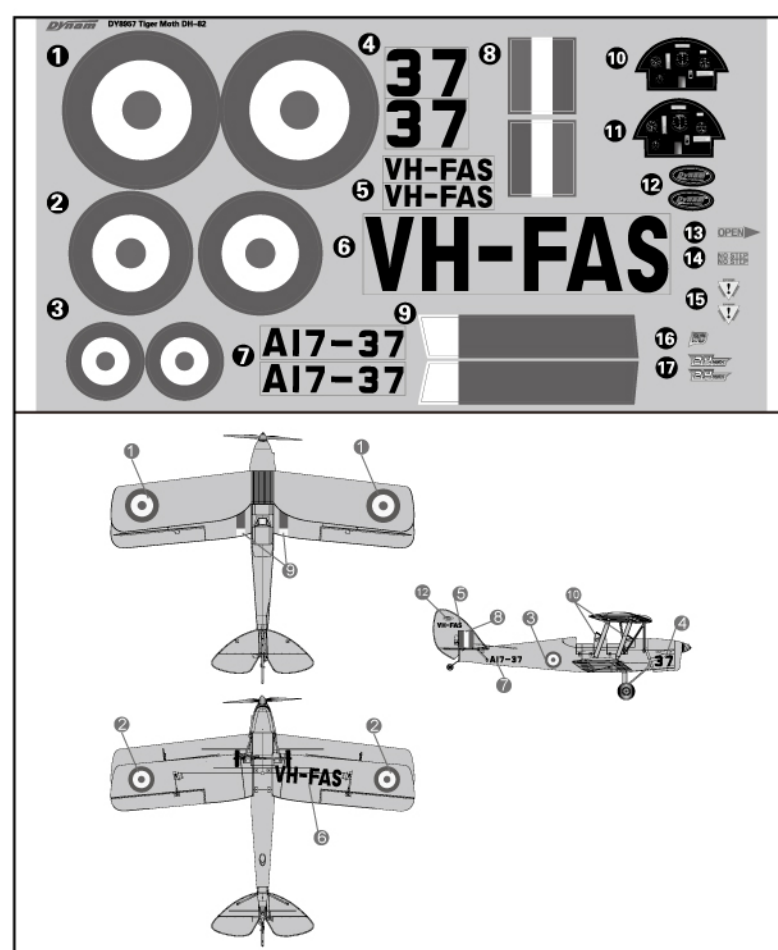

WARNINGS

- The product is not intended for those under 14 years of age without proper adult supervision. The product is not a toy. It is a precision machine requiring proper assembly and setup to avoid accidents and it is the responsibility of the owner to operate this product in a safe manner as it can cause serious personal injury and damage to property due to carelessness or misuse.
 - The spinning rotors on this product can be dangerous! When operating/flying, always be aware of the spinning rotors. Be careful not to let them come close to your body, other people or loose clothing. Keep your hands, fingers and any articles of clothing away from the rotors.
 - Do not attempt to disassemble or modify any of the product components without the assistance of an experienced RC user.
 - Only use the correct type of battery to operate. Using any wrong type of battery will damage the product and possibly make it dangerous to operate.
 - The motor(s) may get hot during use. Always allow 10-15 minutes between each flight for the motor to cool down. This will prolong the life of your product.
 - Choose an appropriate operating site consisting of flat, smooth ground, and clear open field. Do not operate near buildings, high voltage cable lines, or trees to ensure safety operation. Operate in safe area only, away from other people. RC models are prone to accidents, failures, and crashes due to a variety of reasons including, lack of maintenance, pilot error, and radio interference. Pilots are responsible for their actions and damage or injury occurring during the operation.
 - Do not operate in inclement weather, such as rain, wind, snow and darkness.
 - The product is composed of precision electrical components. It is critical to keep the product away from moisture and other contaminants. Do not allow them to get wet. Electrical damage may occur that could affect safe operation.
- Dynam RC guarantees this product to be free of manufacturing faults and material defects. This product has been checked and fine tuned individually by professional pilot and quality control pilot. The warranty does not cover any component parts damaged by use and modification. Please visit <http://www.dynam-rc.cn> for updated product information.
- This product is not a toy. It is not recommended for children under 14 years old and any minor should be accompanied by an adult when operating. This product is a precision machine that requires proper assembly and setup to avoid accidents. Failure to take caution when operating this product may result in serious injury or property damage. It is the owner's responsibility to operate this product in a safe manner. Manufacturer and its distributors are not responsible in any way for any and all bodily injury(s) and/or property damage that may occur from the use of or caused by in any way of this product.
- This product contains chemicals known to the State of California to cause cancer, birth defects or other reproductive harm. Please recycle.
- After each use, always allow the battery to cool down before recharging. When charging the battery pack, do not overcharge! If batteries get hot during charging, discontinue charging immediately and disconnect the battery from the charger. Never leave battery unattended while charging. If you are unsure of how to charge this battery, please seek the advice of experienced RC users. Never let children charge the battery without adult supervision.
 - Always turn on the transmitter before connecting the battery on the model. When turning off the model, always disconnect the battery first, and then turn off the transmitter. If the order is reversed, the model may become uncontrollable and cause serious damage.
 - Never allow batteries to run low or you might lose control of the model.
 - You should complete a successful pre-flight check of your radio equipment and model prior to each flight.
 - Before turning on your model and transmitter, please check to make sure no one else is operating under the same frequency. Frequency interference can cause your model, or other's models to crash. The guidance provided by experienced RC users will be valuable for the assembly, tuning, trimming, and actual first flight.
 - Plastic is very susceptible to damage or deformation due to extreme heat and cold climate. Do not store the model near any source of heat such as oven or heater. Store the model indoors, in a climate-controlled, room temperature environment.

Charge the Li-Po battery pack

Disconnect the battery from the charger when the charging process completed. Do not charge the battery unattended at all time.

Lithium Polymer (LiPo) Battery Warnings

- Never charge a lithium polymer battery with a charger designed for NiCd, NiMH, or any other type of battery chemistry. Use ONLY charger designed for LiPo battery.
- Do not leave LiPo battery unattended during charging.
- Do not overcharge the battery.
- Always put the LiPo battery inside a charging protection container while charging.
- Do not allow LiPo cells to overheat at any time. Cells which reach greater than 140 Fahrenheit (60°C) will usually become damaged and will catch fire.
- Do not allow LiPo cells on or near combustible materials including paper, plastic, carpets, vinyl, leather, and wood, inside an R/C model or full size automobile.
- Do not over discharge LiPo; doing so will damage the battery.
- Do not expose LiPo cell to water or moisture at any time.
- Do not store battery near open flame or heater.
- Do not assemble LiPo cells or pre-assembled packs together with other LiPo cells or packs.
- Always store LiPo battery in a secure location away from children.
- Always remove the LiPo battery if model is involved in any kind of crash. Carefully inspect the battery and connectors for even the smallest damage. CAUTION: cells may be hot!
- Do not allow the electrolyte to get into eyes or on skin. Wash affected areas immediately if they come into contact with electrolyte. Do not alter or modify connectors or wires of a LiPo battery pack.
- Always inspect the condition of the battery before charging and operating.
- Do not short circuit the LiPo battery.
- Do not have contact with a leaky/damaged battery directly.
- Do not charge battery out of recommended temperature rang (0°C-45°C)

Manual of Brushless Motor Speed Controller

Specifications:

Pentium Series											
Class	Model	Cont. Current	Burst Current (>10s)	BEC Mode (Note1)	BEC Output	Battery Cell		User Programmable	Balance Discharge Protection	Weight	Size
						Li-ion	NiMH NiCd				L*W*H
12A	Esc-12	12A	15A	Switch	5V/3A	2-4	5-12	Available	N/A	19g	45*24*9
18A	Esc-18	18A	22A	Switch	5V/3A	2-4	5-12	Available	N/A	19g	45*24*11
25A	Esc-25	25A	35A	Switch	5V/3A	2-4	5-12	Available	N/A	22g	45*24*11
30A	Esc-30	30A	40A	Switch	5V/3A	2-4	5-12	Available	N/A	25g	45*24*11
40A	Esc-40	40A	55A	Switch	5V/3A	2-6	5-18	Available	N/A	35g	55*28*12
50A	Esc-50	50A	80A	Switch	5V/3A	2-6	5-18	Available	N/A	60g	70*31*14
60A	Esc-60	60A	80A	Switch	5V/3A	2-6	5-18	Available	N/A	60g	70*31*14
70A	Esc-70	70A	100A	Switch	5V/3A	2-6	5-18	Available	N/A	62g	70*31*14
80A	Esc-80	80A	100A	Switch	5V/3A	2-6	5-18	Available	N/A	62g	70*31*14

Wiring Diagram:

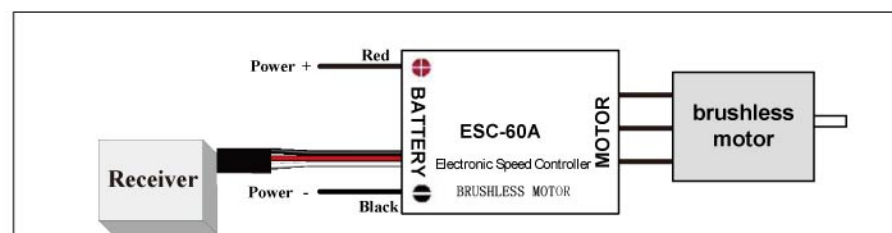

Programmable Items:

- Brake Setting:** Enabled / Disabled, default is Disabled
- Battery Type:** Li-xx(Li-ion or Li-poly) / Ni-xx(NiMH or NiCd), default is Li-xx.
- Low Voltage Protection Mode(Cut-Off Mode):** Soft Cut-Off (Gradually reduce the output power) or Cut-Off (Immediately stop the output power). Default is Soft Cut-Off.
- Low Voltage Protection Threshold(Cut-Off Threshold):** Low / Medium / High, default is Medium.
 - When NOT using balance discharge monitoring and protection function (i.e. Not plugging the balance charge connector into the BDMP socket on the Guard series ESC, the ESC only monitors the voltage of the whole battery pack)
 - For lithium batteries, the number of battery cells is calculated automatically. Low / medium / high cutoff voltage for each cell is: 2.6V/2.85V/3.1V. For example: For a 3 cells lithium pack, when "Medium" cutoff threshold is set, the cut-off voltage will be: 2.85*3=8.55V.
 - For nickel batteries, low / medium / high cutoff voltages are 0%/45%/60% of the startup voltage (i.e. the initial voltage of battery pack), and 0% means the low voltage cut-off function is disabled. For example: For a 10 cells NiMH battery, fully charged voltage is 1.44*10=14.4V, when "Medium" cut-off threshold is set, the cut-off voltage will be: 14.4*45%=6.5V.
 - When using balance discharge monitoring and protection function (i.e. Plugging the balance charge connector on battery pack into the BDMP socket on the Guard series ESC, the ESC monitors not only the voltage of the whole battery pack but also the voltage of each cell). For lithium battery, low / medium / high cut off voltage for each cell is: 2.6V/2.85V/3.1V. When the voltage of any cell in battery pack is lower than the cut-off threshold, the protection function is activated.
- Startup Mode:** Normal /Soft /Super-Soft, default is Normal. Normal is preferred for fixed-wing aircraft. Soft or Super-soft are preferred for helicopters. The initial acceleration of the Soft and Super-Soft modes are slower in comparison, usually taking 1 second for Soft startup or 2 seconds for Super-Soft startup from initial throttle advance to full throttle. If the throttle is closed (throttle stick moved to bottom) and opened again (throttle stick moved to top) within 3 seconds of the initial startup, the restart-up will be temporarily changed to normal mode to get rid of the chances of a crash caused by slow throttle response. This special design is very suitable for aerobatic flight when quick throttle response is needed.
- Timing:** Low / Medium / High, default is Low. *Note2*
Usually, low timing value can be used for most motors. We recommend the Low timing value for 2 poles motor and Medium timing value for motors with more than 6 poles to get a high efficiency. For higher speed, High timing value can be chosen.
Note2: After changing the timing setting, please test your RC model on ground prior to flight!

Begin To Use Your New ESC

Please start the ESC in the following sequences:

- Move the throttle stick to the bottom position and then switch on the transmitter.
- Connect the battery pack to the ESC, the ESC begins the self-test process, a special tone " ♪ 123" is emitted, which means the voltage of the battery pack is in normal range, and then N "beep" tones will be emitted, means the number of lithium battery cells. Finally a long "beep-----" tone will be emitted, which means self-test is OK, the aircraft/helicopter is ready to go flying.
 - If nothing is happened, please check the battery pack and all the connections;

Manual of Brushless Motor Speed Controller

- If a special tone " ♪ 56712" is emitted after 2 beep tones ("beep-beep-"), means the ESC has entered the program mode, it is because the throttle channel of your transmitter is reversed, please set it correctly;
- If the very rapid "beep-beep-, beep-beep-" tones is emitted, means the input voltage is too low or too high, please check your battery's voltage.

- "VERY IMPORTANT!"** Because different transmitter has different throttle range, we strongly suggest you using the "Throttle Range Setting Function" to calibrate throttle range. Please read the instruction on page 4-----"Throttle Range Setting".

Alert Tone

- Input voltage is abnormal: The ESC begins to check the voltage when the battery pack is connected, if the voltage is not in the acceptable range, such an alert tone will be emitted: "beep-beep-, beep-beep-,beep-beep-" (Every "beep-beep-" has a time interval of about 1 second.)
- Throttle signal is abnormal: When the ESC can't detect the normal throttle signal, such an alert tone will be emitted: "beep-, beep-, beep-". (Every "beep-" has a time interval of about 2 seconds)
- Throttle stick is not in the bottom position: When the throttle stick is not in bottom (lowest) position, a very rapid alert tone will be emitted: "beep-, beep-, beep-". (Every "beep-" has a time interval of about 0.25 second.)

Protection Function

- Abnormal start up protection: If the motor fails to start within 2 seconds of throttle application, the ESC will cut-off the output power. In this case, the throttle stick **MUST** be moved to the bottom again to restart the motor. (Such a situation happens in the following cases: The connection between ESC and motor is not reliable, the propeller or the motor is blocked, the gearbox is damaged, etc.)
- Over-heat protection: When the temperature of the ESC is over 110 Celsius degrees, the ESC will reduce the output power.
- Throttle signal loss protection: The ESC will reduce the output power if throttle signal is lost for 1 second, further loss for 2 seconds will cause its output to be cut-off completely.

Program Example

Setting "Start Mode" to "Super-Soft", i.e. value #3 in the programmable item #5

- Enter Program Mode**
Switch on transmitter, move throttle stick to top position, connect battery pack to ESC, wait for 2 seconds, "beep-beep" tone should be emitted. Then wait for another 5 seconds, special tone like " ♪ 56712" should be emitted, which means program mode is entered.
- Select Programmable Items**
Now you'll hear 8 tones in a loop. When a long "beep-----" tone is emitted, move throttle stick to bottom to enter the "Start Mode"
- Set Item Value (Programmable Value)**
"Beep-", wait for 3 seconds; "Beep-beep-", wait for another 3 seconds; then you'll hear "beep-beep-beep", move throttle stick to top position, then a special tone " ♪ 1515" is emitted, now you have set the "Start Mode" item to the value of "Super-Soft"
- Exit Program Mode**
After the special tone " ♪ 1515", move throttle stick to bottom within 2 seconds.

Trouble Shooting

Trouble	Possible Reason	Action
After power on, motor does not work, no sound is emitted	The connection between battery pack and ESC is not correct	Check the power connection. Replace the connector.
After power on, motor does not work, such an alert tone is emitted: "beep-beep-, beep-beep-,beep-beep-" (Every "beep-beep-" has a time interval of about 1 second)	Input voltage is abnormal, too high or too low. The balance charge connector is not located properly in BDMP adapter.	Check the voltage of battery pack Check the connection of the balance charge connector and the BDMP adapter.
After power on, motor does not work, such an alert tone is emitted: "beep-, beep-, beep-" (Every "beep-" has a time interval of about 2 seconds)	Throttle signal is irregular	Check the receiver and transmitter Check the cable of throttle channel
After power on, motor does not work, such an alert tone is emitted: "beep-, beep-, beep-" (Every "beep-" has a time interval of about 0.25 second)	The throttle stick is not in the bottom (lowest) position	Move the throttle stick to bottom position
After power on, motor does not work, a special tone " ♪ 56712" is emitted after 2 beep tone (beep-beep-)	Direction of the throttle channel is reversed, so the ESC has entered the program mode	Set the direction of throttle channel correctly
The motor runs in the opposite direction	The connection between ESC and the motor need to be changed.	Swap any two wire connections between ESC and motor
The motor stop running while in working state	Throttle signal is lost ESC has entered Low Voltage Protection mode Some connections are not reliable	Check the receiver and transmitter Check the cable of throttle channel Land RC model as soon as possible, and then replace the battery pack Check all the connections: battery pack connection, throttle signal cable, motor connections, etc.
Random stop or restart or irregular working state	There is strong electro-magnetic interference in flying field.	Reset the ESC to resume normal operation. If the function could not resume, you might need to move to another area to fly.

Manual of Brushless Motor Speed Controller

Normal startup procedure:

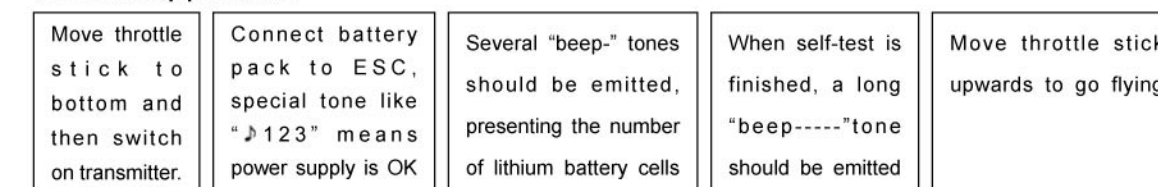

Throttle range setting: (Throttle range should be reset whenever a new transmitter is being used)

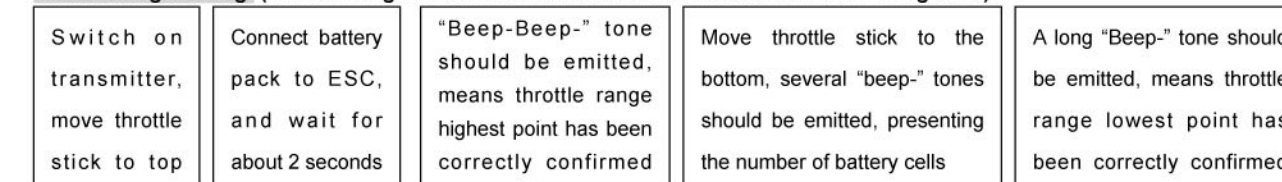

Program the ESC with your transmitter (4 Steps):

- Enter program mode
- Select programmable items
- Set item's value (Programmable value)
- Exit program mode

1. Enter program mode

- Switch on transmitter, move throttle stick to top, connect the battery pack to ESC
- Wait for 2 seconds, the motor should emit special tone like "beep-beep-"
- Wait for another 5 seconds, special tone like " ♪ 56712" should be emitted, which means program mode is entered

2. Select programmable items:

After entering program mode, you will hear 8 tones in a loop with the following sequence. If you move the throttle stick to bottom within 3 seconds after one kind of tones, this item will be selected.

- "beep" brake (1 short tone)
- "beep-beep-" battery type (2 short tone)
- "beep-beep-beep-" cutoff mode (3 short tone)
- "beep-beep-beep-beep-" cutoff threshold (4 short tone)
- "beep-----" startup mode (1 long tone)
- "beep-----beep-" timing (1 long 1 short)
- "beep-----beep-beep-" set all to default (1 long 2 short)
- "beep-----beep-----" exit (2 long tone)

Note: 1 long "beep-----" = 5 short "beep-"

3. Set item value (Programmable value):

You will hear several tones in loop. Set the value matching to a tone by moving throttle stick to top when you hear the tone, then a special tone " ♪ 1515" emits, means the value is set and saved. (Keeping the throttle stick at top, you will go back to step 2 and you can select other items; Moving the stick to bottom within 2 seconds will exit program mode directly)

Items	Tones		
	"beep-" 1 short tone	"beep-beep-" 2 short tones	"beep-beep-beep-" 3 short tones
Brake	Off	On	
Battery type	Li-ion / Li-poly	NiMH / NiCd	
Cutoff mode	Soft-Cut	Cut-Off	
Cutoff threshold	Low	Medium	High
Start mode	Normal	Soft	Super soft
Timing	Low	Medium	High

4. Exit program mode

There are 2 ways to exit program mode:

- In step 3, after special tone " ♪ 1515", please move throttle stick to the bottom position within 2 seconds.
- In step 2, after tone "beep-----beep-----"(ie. The item #8), move throttle stick to bottom within 3 seconds.

DYNAM 2.4GHZ REMOTE CONTROL SYSTEM



INSTALL THE TRANSMITTER BATTERIES

Install 8 new AA batteries into the battery compartment on the back of the transmitter. Turn on the transmitter. The status LED on the transmitter should indicate the capacity level of the batteries. Please replace batteries if the color of the status LED is not green.

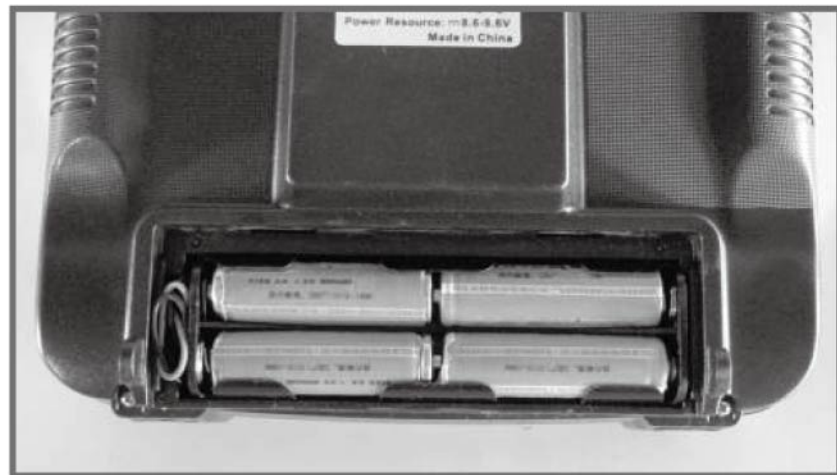

STICK OPERATION

MODE 1	MODE 2	MOVEMENT
<p>THROTTLE</p>		
<p>RUDDER</p>		
<p>ELEVATOR</p>		
<p>AILERONS</p>		