

## CHAPTER 2

# Inspections, Tests and Safety Considerations

### Scope

*Once a PE piping system has been selected and designed for an application, the design is implemented by procuring the pipe, fittings and other necessary appurtenances, installing the system, and placing it in service. Piping installation involves people and machines in motion to move, assemble, install, inspect and test the piping system. Whenever moving machinery, piping parts, and personnel are engaged in piping system construction, safety must be a primary consideration. This chapter presents some of the inspections, tests and safety considerations related to installing PE piping, placing an installed system in service, and operating a PE piping system.*

*Cautionary statements are provided in this chapter, but this chapter does not purport to address all of the product applications, inspections, tests, or construction practices that could be used, nor all of the safety practices necessary to protect persons and property. It is the responsibility of the users of this chapter, installers, inspectors and operators of piping systems to establish appropriate safety and health practices, and to determine the applicability of regulatory limitations before any use, installation, inspection, test or operation.*

### Introduction

Generally, piping system installation begins with the arrival and temporary storage of pipe, fittings, and other goods required for the system. Assembly and installation follow, then system testing and finally, release for operation. Throughout the installation process, various inspections and tests are performed to ensure that the installation is in accordance with specification requirements and that the system when completed is capable of functioning according to its design specifications. In the selection, design, and installation of PE piping systems, professional engineering services, and qualified installers should be used.

PE piping products are integrated pipe and fitting systems for a broad range of commercial, municipal, utility and industrial applications. They may be buried, laid on the surface, supported above grade, installed underwater, or floated on the surface of lakes or rivers.

PE piping products are manufactured from 1/4" (6 mm) diameter through 120" (3050 mm) diameter under applicable industry standards (ASTM, AWWA, etc.) for pressure and non-pressure applications. As well, PE fittings, custom fabrications, special structures and appurtenances are available for full pressure rated, reduced pressure rated, or non-pressure rated applications.

Conventionally extruded PE pipes have homogeneous walls and smooth interior and exterior surfaces. Profile pipes are manufactured by extruding a profile over a mandrel. These pipes have smooth interiors, and may have a smooth or a profiled exterior.

Fittings, fabricated structures, tanks, and manholes are constructed for pressure, low pressure and non-pressure applications. Smaller size fittings are usually injection molded. Larger fittings, fabricated structures, tanks, and manholes are fabricated in manufacturer's facilities. Thermal joining techniques used for fabrication usually limit the design pressure capacity of the structure. Complex structures are generally not suitable for field fabrication.

## **PE Piping in the Field**

After the piping system has been designed and specified, the piping system components must be procured. Typically, project management and purchasing personnel work closely together so that the necessary components are available when they are needed for the upcoming construction work.

### **Packaging for Commercial Transport**

PE fittings, fabrications and pipe are shipped by commercial carriers who are responsible for the products from the time they leave the manufacturing plant until they are accepted by the receiver. Molded fittings and small fabrications and components are usually packaged in cartons. Large orders may be palletized. Large fabrications may require custom packaging. Commercial transport may be by parcel service or commercial carrier in enclosed vans or on flatbed trailers depending on packaging.

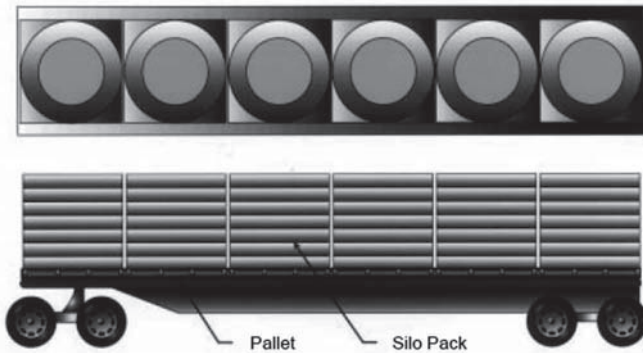

**Figure 1** Typical Truckload of Coiled, Silo-Pack Pipe (40' Trailer)

PE pipe is produced in coils or in straight lengths and shipped on flatbed trailers. Coils are typically limited to 6-inch and smaller sizes. Coils may be laid flat and stacked together into silo packs, or may be individual large vertical coils, or may be reels of coiled pipe. Straight lengths are bundled together in bulk packs or loaded on the trailer in strip loads. Standard straight lengths for extruded pipe are 40 feet long; however, shorter lengths or lengths 60 feet long or longer depending on transportation restrictions may be produced. State transportation restrictions on length, height and width usually govern allowable load configurations. Higher freight costs may apply to loads that exceed length, height, or width restrictions. Although PE pipe is lightweight, weight limitations may restrict load size for very heavy wall or longer length pipe. Profile wall extruded pipes 96-inch ID (2438 mm ID) and 120-inch ID (3048 mm ID) will exceed 8 feet overall permissible width, and are subject to wide load restrictions.

Figures 1 through 3 are general illustrations of truckload and packaging configurations for conventionally extruded PE pipes. Actual truckloads and packaging may vary from the illustrations. “Nesting”, or sliding a smaller pipe length inside a larger pipe, is generally not practiced for commercial flatbed loads because it is difficult to remove the inner pipe when the load is delivered at the jobsite, because nesting can result in an overweight load, and because most commercial flatbed trailers do not have structural bulkheads at both ends to prevent nested pipes from sliding out during acceleration or braking. Fully enclosed containers for overseas delivery can occasionally be nested. Occasionally, silos of small tubing sizes may be “nested” in silos of larger coiled pipe. Nested silos must have special packaging to lift the tubing silo out of the pipe silo. De-nesting should only be performed after the nested silos have been unloaded from the truck and placed on the ground.

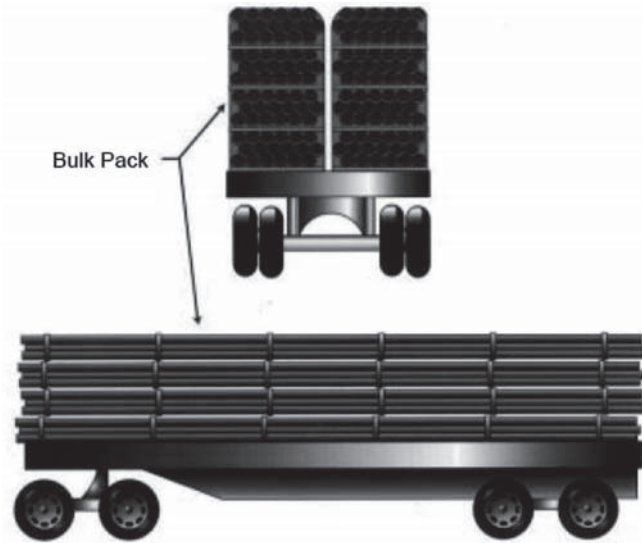

**Figure 2** Typical Straight Length Bulk Pack Truckload

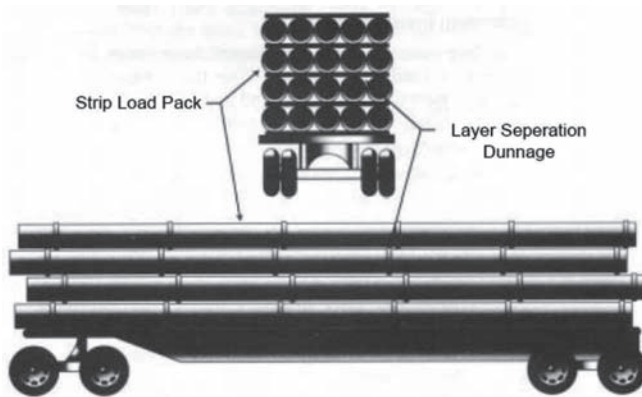

**Figure 3** Typical Straight Length Strip Load Truckload

Occasionally, when coiled pipe silo packs and boxed fittings are shipped together, fitting cartons are placed in the center of the silo packs. Tanks, manholes, and large fittings and custom fabrications are usually loaded directly onto flatbed trailers.

### Receiving Inspection

Few things are more frustrating and time consuming than not having what you need, when you need it. Before piping system installation begins, an important initial step is a receiving inspection of incoming products. Construction costs can

be minimized, and schedules maintained by checking incoming goods to be sure the parts received are the parts that were ordered, and that they arrived in good condition and ready for installation.

### Checking and Inspecting the Order

When a shipment is received, it should be checked to see that the correct products and quantities have been delivered in a condition that is suitable for installation. Several documents are used here. The Purchase Order or the Order Acknowledgment lists each item by its description, and the required quantity. The incoming load will be described in a Packing List which is attached to the load. The descriptions and quantities on the Packing List should match those on the Purchase Order or the Order Acknowledgment.

The carrier will present a Bill of Lading that generally describes the load as the number of packages the carrier received from the manufacturing plant. The Order Acknowledgment, Packing List, and Bill of Lading should all be in agreement. Any discrepancies must be reconciled among the shipper, the carrier, and the receiver. The receiver should have a procedure for reconciling any such discrepancies.

There is no substitute for visually inspecting an incoming shipment to verify that the paperwork accurately describes the load. Products are usually identified by markings on each individual product. These markings should be checked against the Order Acknowledgment and the Packing List. The number of packages and their descriptions should be checked against the Bill of Lading.

Before and during unloading, the load should be inspected for damage that may occur anytime products are handled. Obvious damage such as cuts, abrasions, scrapes, gouges, tears, and punctures should be carefully inspected. Manufacturers should be consulted for damage assessment guidelines. Product with damage that could compromise product performance should be segregated and a resolution discussed with the manufacturer.

When pipe installation involves saddle fusion joining, diesel smoke on the pipe outside surface may be a concern because it may reduce the quality of saddle fusion joints. Smoke damage is effectively prevented by covering at least the first third of the load with tarpaulins or by using truck tractors with low exhaust. If smoke tarps are required, they should be in place covering the load when it arrives.

### Receiving Report & Reporting Damage

The delivering truck driver will ask the person receiving the shipment to sign the Bill of Lading, and acknowledge that the load was received in good condition. Any damage, missing packages, etc., should be noted on the bill of lading at that time.

Shipping problems such as damage, missing packages, document discrepancies, incorrect product, etc., should be reported to the product supplier immediately. Shipping claims must be filed within 7 days.

## Field Handling

PE piping product transportation and handling is generally subject to governmental safety regulations such as OSHA in the United States or CCOSH in Canada. Persons transporting and handling PE piping products should be familiar with applicable governmental safety regulations. Additional PE pipe handling and transportation information is available in the PPI Material Handling Guide<sup>(1)</sup>, and in handling and unloading recommendations from product manufacturers. The responsibility for safe transport and handling; however, rests primarily with persons that actually perform transport and handling activities.

Manufacturer handling and unloading recommendations are typically given to the truck driver when the load leaves the manufacturing plant with instructions for the truck driver to give the manufacturer's handling and unloading recommendations to jobsite personnel upon delivery.

*Always observe applicable governmental safety regulations and manufacturer's handling and unloading recommendations when transporting or handling PE piping products in the field. Unsafe handling can result in damage to property or equipment, and be hazardous to persons in the area. Keep unnecessary persons away from the area during unloading and while handling pipe and piping components. See and be seen at all times. All persons involved in unloading and handling PE pipe and piping components should be sure that they can see all other persons and be seen by all other persons engaged in unloading and handling.*

PE pipe is tough, lightweight, and flexible. Installation does not usually require high capacity lifting equipment. Pipe up to about 8" (219 mm) diameter and weighing roughly 6 lbs per foot (9 kg per m) or less can frequently be handled manually. Heavier, larger diameter pipe will require appropriate handling equipment to lift, move and lower the pipe. Pipe must not be dumped, dropped, pushed, or rolled into a trench.

Lengths of heat fused PE pipe may be cold bent in the field. The PE pipe manufacturer should be consulted for field bending radius recommendations. Field bending usually involves sweeping or pulling the pipe string into the desired bend radius, then installing permanent restraint such as embedment around a buried pipe, to maintain the bend. If used, temporary blocking should be removed before backfilling to avoid point loads against the pipe.

*Considerable force may be required to field bend larger pipe, and the pipe may spring back forcibly if holding devices slip or are inadvertently released while bending. Observe appropriate safety precautions during field bending.*

## Handling Equipment

Unloading and handling equipment must be appropriate for the type of packaging, must be in safe operating condition, and must have sufficient capacity (load rating) to safely lift and move the product as packaged. Equipment operators should be trained and preferably, certified to operate the equipment. Safe handling and operating procedures must be observed.

Although PE piping components are lightweight compared to similar components made of metal, concrete, clay, or other materials, larger components can be heavy. Lifting and handling equipment must have adequate rated capacity to safely lift and move components. Equipment that lifts from the bottom of the load such as a forklift, or from above the load such as a crane, a side boom tractor, or an extension boom crane is used for unloading. Above the load lifting equipment may employ slings or slings and spreader bars to lift the load.

When using a forklift, or forklift attachments on equipment such as articulated loaders or bucket loaders, lifting capacity must be adequate at the load center on the forks. Forklift equipment is rated for a maximum lifting capacity at a distance from the back of the forks. If the weight-center of the load is farther out on the forks, lifting capacity is reduced.

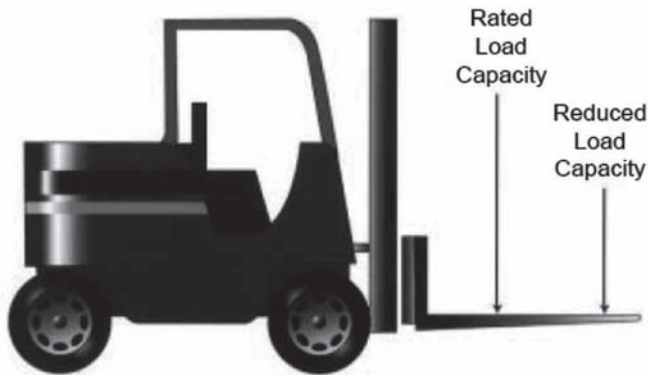

**Figure 4** Forklift Load Capacity

Before lifting or transporting the load, forks should be spread as wide apart as practical, forks should extend completely under the load using fork extensions if necessary, and the load should be as far back on the forks as possible. During transport, a load on forks that are too short or too close together, or a load too far out on the forks, may become unstable and pitch forward or to the side, and result in damage to the load or property, or hazards to persons.

Above the load lifting equipment such as cranes, extension boom cranes, and side boom tractors, should be hooked to wide fabric choker slings that are secured

around the load or to lifting lugs on the component. Wire rope slings and chains can damage components, can slip, and should not be used. Spreader bars should be used when lifting pipe or components longer than 20'. *Before use, inspect slings and lifting equipment. Equipment with wear or damage that impairs function or load capacity should not be used.*

### Unloading Site

A suitable unloading site will be generally level and large enough for the carrier's truck, handling equipment and its movement, and for temporary load storage.

### Unloading Bulk Packaged Pipe, Fittings and Fabrications

Silo packs and other palletized packages should be unloaded from the side or end with a forklift. Non-palletized pipe, fittings, fabrications, manholes, tanks, or other components should be unloaded from above with suitable lifting equipment and wide fabric slings, or from the side with a forklift.

*Pipe, fittings, fabrications, tanks, manholes, and other components must not be pushed or rolled or dumped off the truck, or dropped.*

### Unloading Large Fabrications, Manholes and Tanks

Large fabrications, manholes and tanks should be unloaded using a wide web choker sling and lifting equipment such as an extension boom crane, crane, or lifting boom. The choker sling is fitted around the manhole riser or near the top of the tank. Do not use stub outs, outlets, or fittings as lifting points, and avoid placing slings where they will bear against outlets or fittings. Larger diameter manholes and tanks are typically fitted with lifting lugs. All lifting lugs must be used. *The weight of the manhole or tank is properly supported only when all lugs are used for lifting. Do not lift tanks or manholes containing liquids.*

### Pre-Installation Storage

The size and complexity of the project and the components, will determine pre-installation storage requirements. For some projects, several storage or staging sites along the right-of-way may be appropriate, while a single storage location may be suitable for another job.

The site and its layout should provide protection against physical damage to components. General requirements are for the area to be of sufficient size to accommodate piping components, to allow room for handling equipment to get around them and to have a relatively smooth, level surface free of stones, debris, or other material that could damage pipe or components, or interfere with handling. Pipe may be placed on 4-inch wide wooden dunnage, evenly spaced at intervals of 4 feet or less.



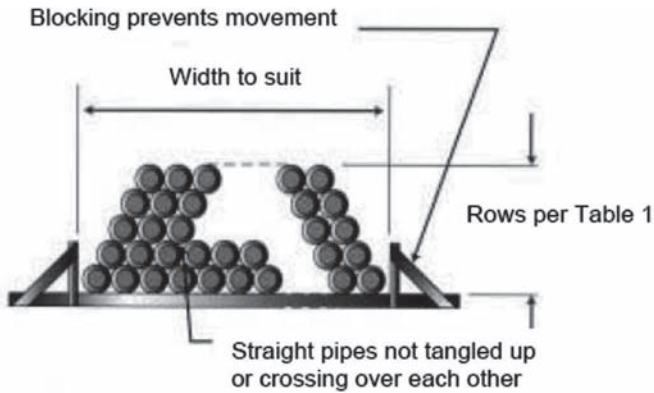

**Figure 5** Loose Pipe Storage

### Pipe Stacking Heights

Coiled pipe is best stored as-received in silo packs. Individual coils may be removed from the top of the silo pack without disturbing the stability of the remaining coils in the silo package.

Pipe received in bulk packs or strip load packs should be stored in the same package. If the storage site is flat and level, bulk packs or strip load packs may be stacked evenly upon each other to an overall height of about 6'. For less flat or less level terrain, limit stacking height to about 4'.

Before removing individual pipe lengths from bulk packs or strip load packs, the pack must be removed from the storage stack, and placed on the ground.

**TABLE 1**  
**Suggested Jobsite Loose Storage Stacking Height Limits for PE Pipe**

Conventionally Extruded Solid Wall Pipe OD Size	Suggested Stacking Height Limits, Rows		Profile Wall Pipe ID Size (ASTM F 894 <sup>(2)</sup> )	Suggested Stacking Height, Rows
	DR Above 17	DR 17 & Below		
4	15	12	18	4
5	12	10	21	3
6	10	8	24	3
8	8	6	27	2
10	6	5	30	2
12	5	4	33	2
14	5	4	36	2
16	4	3	42	1
18	4	3	48	1
20	3	3	54	1
22	3	2	60	1
24	3	2	66	1
26	3	2	72	1
28	2	2	84	1
30	2	2	96	1
32	2	2	120	1
36	2	1		
42	1	1		
48	1	1		
54	1	1		
63	1	1		

Individual pipes may be stacked in rows. Pipes should be laid straight, not crossing over or entangled with each other. The base row must be blocked to prevent sideways movement or shifting. The interior of stored pipe should be kept free of debris and other foreign matter.

**Exposure to UV and Weather**

PE pipe products are protected against deterioration from exposure to ultraviolet light and weathering effects with antioxidants, and thermal and UV stabilizers. UV stabilization formulations for color products and for black products are different.

Color products use sacrificial UV stabilizers that are depleted by the UV energy absorbed. For this reason, unprotected outdoor storage for color products is generally about 2 years or less; however, some manufacturers may use UV stabilization formulations that allow longer unprotected outside storage. Where extended storage is anticipated, color products should be covered or measures should be taken to protect color product from direct UV exposure. Consult color product manufacturers for unprotected outdoor storage recommendations.

Black products contain at least 2% carbon black to shield the material against UV deterioration<sup>(3)</sup>. Black products with and without stripes are generally suitable for outdoor storage without covering or protection against UV exposure. Products that are stored for many years may be affected by other environmental conditions or obsolescence due to improvements in materials or processes.

### Cold Weather Handling

Temperatures near or below freezing will affect PE pipe by increasing stiffness and reducing resistance to impact damage. PE remains ductile at temperatures below -40°F (-40°C). In colder conditions, allow more time to conduct handling and installation procedures that bend and flex the pipe. Extra care should be taken not to drop pipe or fabricated structures, and to keep handling equipment and other things from forcefully impacting the pipe.

Ice, snow, and rain are not harmful to the material, but unsure footing and traction require greater care and caution to prevent damage or injury. Inclement weather can make pipe surfaces especially slippery. Do not walk on pipe.

## General Considerations Before and During Installation

### Pre-Construction

Inspections and tests begin before construction. Jobsite conditions dictate how piping may be installed and what equipment is appropriate for construction. Soil test borings and test excavations may be useful to determine soil bearing strength and whether or not native soils are suitable as backfill materials in accordance with project specifications.

In slipline or pipe bursting rehabilitation applications, the deteriorated pipeline should be inspected by remote TV camera to locate structurally deteriorated areas, obstructions, offset and separated joints, undocumented bends, and service connections.

The installer should carefully review contract specifications and plans. Different piping materials require different construction practices and procedures. These differences should be accurately reflected in the contract documents. Good plans and specifications help protect all parties from unnecessary claims and liabilities. Good documents also set minimum installation quality requirements, and the testing and inspection requirements that apply during the job.

### Joining and Connections

For satisfactory material and product performance, system designs and installation methods rely on appropriate, properly made connections. An inadequate or

improperly made field joint may cause installation delays, may disable or impair system operations, or may create hazardous conditions. Joining and connection methods will vary depending upon requirements for internal or external pressure, leak tightness, restraint against longitudinal movement (thrust load capacity), application and operation conditions, construction and installation requirements, and the products being joined.

PE pressure piping products are connected to themselves and to piping products from other materials using methods that seal and restrain against longitudinal thrust loads. These methods include butt, socket and saddle fusion, electrofusion couplings and saddles, and mechanical methods such as MJ Adapters, flanges, and restrained mechanical couplings.

In some circumstances, external restraint may be necessary for connections between PE and non-PE piping, such as for connections between butt-fused PE pressure pipe and bell and spigot joined PVC or ductile iron pipe. Longitudinal thrust forces that may develop in PE pressure pipe may be sufficient to disjoin unrestrained PVC or ductile iron joints that seal but do not restrain. To restrain longitudinal thrust forces, PE pressure pipe may be fitted with a wall anchor or electrofusion restraints to anchor against movement from longitudinal thrust forces.

PE non-pressure piping may require less or no restraint and may be connected using gasketed bell and spigot joints, extrusion welding, compression couplings, and various types of elastomeric seals. Sealed, unrestrained joints that may be suitable for non-pressure service are not suitable for PE pressure service.

Before using a joining or connection method, the limitations of the joining or connection method must be taken into account. Where a joining or connection method is suitable, the manufacturer's joining procedures, tools and components required to construct and install joints in accordance with manufacturer's recommendations should always be used.

Field connections are controlled by and are the responsibility of the field installer. Some joining procedures such as heat fusion, electrofusion and thermal welding require trained and qualified personnel. Some joining equipment such as larger butt fusion machines, saddle fusion and electrofusion equipment require persons that are properly trained in equipment operation. For regulated pipelines, the authority having jurisdiction may require certification of joining proficiency. Before heat fusion or electrofusion joining is performed at the jobsite, the contractor should obtain joining procedures and inspection criteria from the PE product manufacturer, and should obtain documentation of joining proficiency and qualification for persons making heat fusion or electrofusion joints. A discussion of joining and connecting PE piping products is presented in the Polyethylene Joining Procedures chapter in this handbook and in PPI TN-36<sup>(4)</sup>.

### Cleaning Before Joining

All field connection methods and procedures require component ends to be clean, dry, and free of detrimental surface defects before the connection is made. Contamination and unsuitable surface conditions usually produce an unsatisfactory connection. Gasketed joints may require appropriate lubrication.

Cleaning component ends before joining may require removing surface deposits to planning (facing), abrading or scraping the pipe surface. Surface dust and light soil may be removed by wiping the surfaces with clean, dry, lint free cloths. Heavier soil may be washed or scrubbed off with soap and water solutions, followed by thorough rinsing with clear water, and drying with dry, clean, lint-free cloths.

Before using chemical cleaning solvents, the user should know the potential risks and hazards and appropriate safety precautions should be taken. Hazard information is available from chemical manufacturer's instructions and the MSDS for the chemical. Some solvents may leave a residue on the pipe, or may be incompatible or deleterious when used with PE, for example, solvents that contain hydrocarbon liquids such as WD-40 or kerosene will contaminate the pipe and prevent heat fusion bonding. General information on PE compatibility with various chemicals is available in PPI Technical Report TR-19<sup>(5)</sup>.

Surface damage that could detrimentally affect sealing or pipe performance generally requires removing the damaged section. See "Damage Inspections" below.

### Field Fusion Joining

Heat fusion joining may be performed in any season and in hot or cold conditions. During inclement weather, a temporary shelter should be set-up around the joining operation to shield heat fusion operations from rain, frozen precipitation, and high wind conditions. Wind chill can reduce heating plate temperature or chill melted component ends before joining. If fusion joining operations cannot be protected against dust contamination during severe windblown dust conditions, joining may need to be temporarily suspended until conditions improve.

*Most heat fusion equipment is electrically powered, but is not explosion proof. The fusion equipment manufacturer's instructions should be observed at all times and especially when heat fusion is to be performed in an atmosphere that may be volatile, such as coal or grain dust or in areas where gas or gas fumes may be present.*

*When installing large diameter PE pipe in a butt fusion machine, do not bend the pipe against an open fusion machine collet or clamp. The pipe may suddenly slip out of the open clamp, and cause injury or damage.*

## During Construction and Installation

Tests and inspections performed during construction may include damage inspections, butt fusion joint quality tests, soil tests, pipe deflection tests for ID controlled products such as extruded profile wall pipe, or pressure leak tests.

### Damage Inspections

Damage such as cuts, scrapes, gouges, tears, cracks, punctures, and the like may occur during handling and installation. Damage may affect joint integrity or sealing, or may compromise pipeline performance. The following guidelines may be used to assess surface damage significance.

For PE pipelines, damage should not exceed about 10% of the minimum wall thickness required for the pipeline's operating pressure or the minimum wall thickness required to meet structural design requirements. Excessive damage generally requires removing the damaged section or reinforcement with a full encirclement repair clamp. Excessively deep cuts, abrasions or grooves cannot be repaired by using hot gas or extrusion welding to fill the damaged area with PE material because these methods do not provide sufficient bond strength for pressure service or to restore structural strength.

If damage is not excessive, the shape of the damage may be a consideration. Sharp notches and cuts may be dressed smooth so the notch is blunted. Blunt scrapes or gouges should not require attention. Minor surface abrasion from sliding on the ground or insertion into a casing should not be of concern.

Damage such as punctures and tears will generally require cutting the pipe to remove the damaged section and replacement with undamaged pipe. Small punctures may occasionally be repaired with patching saddles that are saddle fused or electrofused over the puncture.

### Butt Fusion Joint Quality

Visual inspection is the most common butt fusion joint evaluation method for all sizes of conventionally extruded PE pipe. Visual inspection criteria for butt fusion joints should be obtained from the pipe manufacturer. Hydraulic butt fusion equipment is typically fitted for connection to data logging devices that can record equipment temperature, time and pressure conditions during joining. The record may be used to document equipment conditions when making field fusions, and to supplement field joining quality assurance using visual inspection and procedural oversight. Data logger records may be used to compare equipment operation during field fusion joining to data logger equipment operation records of properly made fusions (Butt fusion joining procedures are addressed in Chapter 9) where joint integrity has been verified.

To confirm joint integrity, operator procedure, and fusion machine set-up, fusion joints may be destructively tested. Destructive laboratory tests of tensile specimens prepared from butt fusion joined pipes may be performed per ASTM D 638<sup>(6)</sup> (standard tensile) or ASTM F 2634<sup>(7)</sup> (tensile impact). Tensile tests are usually compared to specimens without joints prepared from the parent pipe. Bent strap tests are usually limited to smaller pipe sizes. Bent strap test specimens from pipe with heavier walls require considerable bending force and attention to safety. Specially designed hydraulic press equipment may be used in the shop to conduct bend tests of heavy wall products. Bent strap tests in the shop or in the field require safety measures against inadvertent release, joint failure or springback during bending.

The bent strap test specimen is prepared by making a trial butt fusion and allowing it to cool to ambient temperature. A test strap that is at least 6" or 15 pipe wall thicknesses long on each side of the fusion, and about 1" or 1-1/2 wall thicknesses wide is cut out of the trial fusion pipe as illustrated in Figure 6. The strap is then bent so that the ends of the strap touch. Any disbondment at the fusion is unacceptable and indicates poor fusion quality. If failure occurs, fusion procedures and/or machine set-up should be changed, and a new trial fusion and bent strap test specimen should be prepared and tested. Field fusion should not proceed until a test joint has passed the bent strap test.

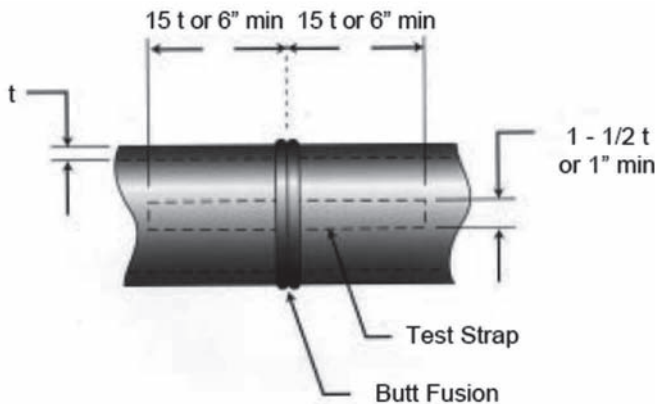

**Figure 6** Bent Strap Test Specimen

### Soil Tests

During buried pipe installation, work should be checked throughout the construction period by an inspector who is thoroughly familiar with the jobsite, contract specifications, materials, and installation procedures. Inspections should reasonably ensure that significant factors such as trench depth, grade, pipe

foundation (if required), quality and compaction of embedment backfill, and safety are in compliance with contract specifications and other requirements. To evaluate soil stability, density and compaction, appropriate ASTM tests may be required in the contract specifications.

### Deflection Tests for ID controlled Pipes

Deflection tests are typically based on an allowable percent vertical deflection of the pipe inside diameter. Deflection tests are generally limited to ID controlled PE piping such as extruded profile wall pipe. Conventionally extruded solid wall pipe is OD controlled so it is difficult if not impossible to determine a base ID for vertical deflection tests. Solid wall pipe extrusion also produces in a slight toe-in at the pipe ends. While internal fusion beads have negligible effects on fluid flows, the ID at butt fusions is reduced at butt fusions. For these reasons deflection testing is limited to ID controlled pipes and is not recommended for OD controlled conventionally extruded solid wall PE piping.

For ID controlled extruded profile pipes, pipe deflection may be used to monitor the installation quality. Improperly embedded pipe can develop significant deflection in a short time, thus alerting the installer and the inspector to investigate the problem. Inspection should be performed as the job progresses, so errors in the installation procedure can be identified and corrected.

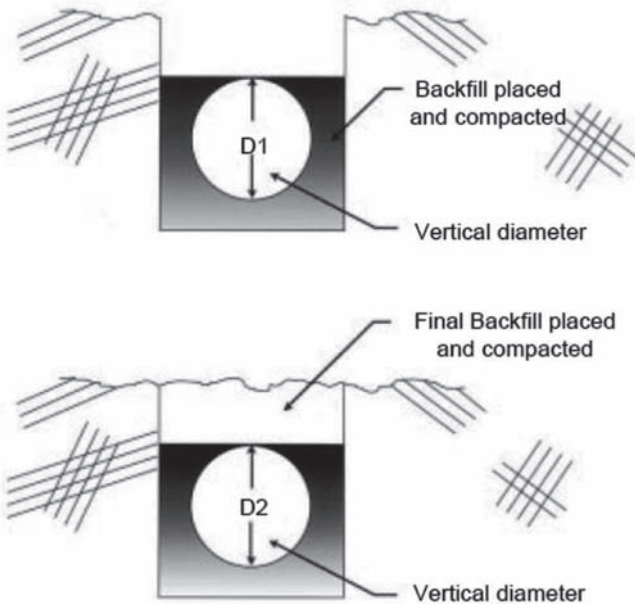

**Figure 7** Determining Initial Deflection



Initial deflection checks of ID controlled extruded profile pipe may be performed after embedment materials have been placed and compacted. The inside diameter of the pipe is measured after backfill materials have been placed to the pipe crown, and compacted. This is D1. Then final backfill materials are placed and compacted, and the pipe inside diameter is measured again at the exact location where the prior measurement was taken. This is D2.

Percent initial deflection is calculated using the following:

$$(1) \quad \% \text{ Deflection} = \left( \frac{D1 - D2}{D1} \right) 100$$

Where *D1* and *D2* are as defined above and depicted in Figure 7.

Another method to measure deflection is to pull a pre-sized mandrel (sewer ball) through the pipe. The mandrel should be sized so that if the pipe exceeds allowable deflection, the mandrel is blocked.

To properly size the mandrel, the allowable vertical diameter of the pipe must be established. It is necessary to account for pipe ID manufacturing tolerances and any ovality that may occur during shipping. Pipe base ID dimensions and tolerances should be obtained from the manufacturer. The maximum mandrel diameter is calculated as follows:

$$(2) \quad D_M = D - \left( \frac{Dy}{100} \right)$$

**WHERE**

*D<sub>M</sub>* = maximum mandrel diameter, in

*D* = base pipe ID, in

*y* = allowable deflection, percent

$$(3) \quad D = D_i - \sqrt{A^2 + B^2}$$

*D<sub>i</sub>* = nominal pipe ID, in

*A* = ID manufacturing tolerance, in

$$(4) \quad B = 0.03 D_i$$

*B* = shipping ovality, in

For buried large diameter PE pipe that has been poorly backfilled, excessive deflection may be correctable using point excavation to remove backfill, then reinstalling embedment materials in accordance with recommended procedures.

## Post Installation

### Leak Testing – Considerations for All Procedures

The intent of leak testing is to find unacceptable joint leakage in pressure or non-pressure piping systems. If leaks exist, they may manifest themselves by leakage or rupture. Leak tests of pressure systems generally involve filling the system or a section of the system with a liquid or gaseous fluid and applying internal pressure to determine resistance to leakage. Leak tests of non-pressure systems typically involve testing sections of the system or individual joints using end plugs or bulkheads to determine resistance to leakage.

Safety is of paramount importance when conducting pressurized internal fluid leak tests. Although routinely performed, leak tests may be the very first time a newly installed system or repair will be subjected to stress.

- *Even at relatively low internal pressures, leak testing with a pressurized internal fluid can generate very high forces that can be dangerous or even fatal if suddenly released by the failure of a joint or a system component or a testing component.*
- *Always take safety precautions when conducting pressurized fluid leak tests.*
- *Restrain pipe, components and test equipment against movement in the event of failure. Joints may be exposed for leakage inspection provided that restraint is maintained.*
- *Keep persons not involved in testing a safe distance away while testing is being conducted.*

Liquids such as water are preferred as test fluids because less energy is released if something in the test section fails catastrophically. During a pressure leak test, energy (internal pressure) is applied to stress the test section. If the test fluid is an incompressible liquid such as water, the energy applied to pressurize the liquid transfers primarily to the pipe and components in the test section. However, if the test fluid is a compressible gas, energy is applied to compress the gas as well as to stress the piping section. If a catastrophic failure occurs during a pressurized liquid leak test, the overall applied energy is much lower, and energy dissipation is rapid. However, if catastrophic failure occurs during a pressurized gas test, energy release is many times greater, much more forceful and longer duration.

- Where hydrostatic testing is specified, never substitute compressed gas (pneumatic) for liquid (hydrostatic) testing.
- *Test pressure is temperature dependent.* If possible, test fluid and test section temperatures should be less than 80°F (27°C). At temperatures above 80°F (27°C), reduced test pressure is required. Contact the pipe manufacturer for technical assistance with elevated temperature pressure reduction. Sunlight heating of exposed PE pipe especially black PE pipe can result in high pipe temperature. Before applying test pressure, allow time for the test fluid and the test section to

temperature equalize. Hydrostatic leak tests typically use cooler liquids so the liquid filled test section will tend to equalize to a lower temperature near test liquid temperature. Compressed gases used in pneumatic leak tests do not have similar temperature lowering effects, so it is more likely that test pressures will have to be reduced due elevated temperature effects when conducting pneumatic leak tests. Bursting can result if test pressure is not reduced for elevated test section temperature.

- *Leak Test Pressure and Duration* – The maximum allowable leak test pressure and leak test time including initial expansion, and time at leak test pressure should be in accordance with equation (5) and Tables 1 and 2.

$$(5) \quad P_{(T)} = \frac{2 \times HDS \times F_t \times H_T}{(DR - 1)}$$

**WHERE**

- P<sub>(T)</sub>** = Leak Test Pressure, psi (MPa), for Leak Test Time, T
- T** = Leak Test Time, hours
- HDS** = PE material hydrostatic design stress for water at 73°F (23°C), psi (MPa)
- F<sub>t</sub>** = PE material temperature reduction factor
- H<sub>T</sub>** = Leak test duration factor for leak test time, T
- DR** = Pipe dimension ratio

**TABLE 2**  
Leak Test Duration Factor, “H<sub>T</sub>”

Leak Test Pressure, P <sub>(T)</sub> , psi (MPa)	Leak Test Time, T, hours	Leak Test Duration Factor, H <sub>T</sub>
P <sub>(8)</sub>	≤ 8	1.50
P <sub>(48)</sub>	≤ 48	1.25
P <sub>(120)</sub>	≤ 120	1.00

**TABLE 3**  
PE Material Hydrostatic Design Stress

PE Material Designation	HDS for Water at 73°F (23°C), psi (MPa)
PE2606 (PE2406)	630 (4.3)
PE2708	800 (5.5)
PE3608 (PE3408)	800 (5.5)
PE3710 & PE4710	1000 (6.9)

Various PE materials can have different elevated temperature performance. Consult the PE pipe manufacturer for the applicable temperature reduction factor, “F<sub>t</sub>”.

Examples:

1. What is the maximum leak test pressure for a DR 11 PE4710 pipe for a 24 hour leak test where the pipe temperature is 125°F (52°C)?

Answer: From Table 1, “ $H_T$ ” = 1.25, and from Table 2, HDS = 1000 psi. The PE pipe manufacturer provided a temperature reduction factor, “ $F_t$ ”, of 0.70.

$$P_{(24)} = \frac{2 \times 1000 \times 0.70 \times 1.25}{(11 - 1)} = 175 \text{ psi}$$

2. What is the maximum leak test pressure for a DR 13.5 PE2606 pipe for a 6 hour leak test where the pipe temperature is 68°F (20°C)? For a 96 hour leak test?

Answer: From Table 1, “ $H_T$ ” = 1.50 for a 6 hour leak test, and “ $H_T$ ” = 1.00 for a 96 hour leak test; from Table 2, HDS = 630 psi. The PE pipe manufacturer provided a temperature reduction factor, “ $F_t$ ”, of 1.00.

$$P_{(6)} = \frac{2 \times 630 \times 1.00 \times 1.50}{(13.5 - 1)} = 151.2 \text{ psi}$$

$$P_{(96)} = \frac{2 \times 630 \times 1.00 \times 1.00}{(13.5 - 1)} = 100.8 \text{ psi}$$

The piping manufacturer should be consulted before using pressure testing procedures other than those presented here. Other pressure testing procedures may or may not be applicable depending upon piping products and/or piping applications.

#### Pressure System Leak Testing – Hydrostatic

Hydrostatic pressure leak tests of PE pressure piping systems should be conducted in accordance with ASTM F 2164<sup>(8)</sup>. The preferred hydrostatic testing liquid is clean water. Other non-hazardous liquids may be acceptable.

- *Restraint* –The pipeline test section must be restrained against movement in the event of catastrophic failure. Joints may be exposed for leakage examination provided that restraint is maintained.
- The testing equipment capacity and the pipeline test section should be such that the test section can be pressurized and examined for leaks within test duration time limits. Lower capacity testing and pressurizing equipment may require a shorter test section.

- Test equipment and the pipeline test section should be examined before pressure is applied to ensure that connections are tight, necessary restraints are in place and secure, and components that should be isolated or disconnected are isolated or disconnected. All low pressure filling lines and other items not subject to the test pressure should be disconnected or isolated.

For pressure piping systems where test pressure limiting components or devices have been isolated, or removed, or are not present in the test section, the maximum allowable test pressure for a leak test duration of 8 hours or less is 1.5 times the system design pressure at the lowest elevation in the section under test. If lower pressure rated components cannot be removed or isolated from the test section, the maximum test pressure is the pressure rating of the lowest pressure rated component that cannot be isolated from the test section. Test pressure is temperature dependent and must be reduced at elevated temperatures.

- The test section should be completely filled with the test liquid, taking care to bleed off any trapped air. Venting at high points may be required to purge air pockets while the test section is filling. Venting may be provided by bleed valves or equipment vents.
- The test procedure consists of initial expansion, and test phases. For the initial expansion phase, the test section is pressurized to test pressure and make-up test liquid is added as required to maintain maximum test pressure for four (4) hours. For the test phase, the test pressure is reduced by 10 psi. This is the target test pressure. If the pressure remains steady (within 5% of the target test pressure) for an hour, leakage is not indicated.
- If leaks are discovered, depressurize the test section before repairing leaks. Correctly made fusion joints do not leak. *Leakage at a butt fusion joint may indicate imminent catastrophic rupture. Depressurize the test section immediately if butt fusion leakage is discovered.* Leaks at fusion joints require the fusion joint to be cut out and redone.
- If the pressure leak test is not completed due to leakage, equipment failure, etc., the test section should be de-pressurized and repairs made. Allow the test section to remain depressurized for at least eight (8) hours before retesting.

#### Pressure System Leak Testing – Pneumatic

The Owner and the responsible Project Engineer should approve compressed gas (pneumatic) leak testing before use. Pneumatic testing should not be considered unless one of the following conditions exists:

- The piping system is so designed that it cannot be filled with a liquid;  
or
- The piping system service cannot tolerate traces of liquid testing medium.

The pressurizing gas should be non-flammable and non-toxic.

- *Restraint* – The pipeline test section must be restrained against movement in the event of catastrophic failure. Joints may be exposed for leakage examination provided that restraint is maintained.
- Leak test equipment and the pipeline test section should be examined before pressure is applied to ensure that connections are tight, necessary restraints are in place and secure, and components that should be isolated or disconnected are isolated or disconnected. All low pressure filling lines and other items not subject to the leak test pressure should be disconnected or isolated.
- *Leak Test Pressure* – For pressure piping systems where test pressure limiting components or devices have been isolated, removed, or are not present in the test section, the maximum allowable test pressure is 1.5 times the system design pressure for a leak test duration of 8 hours or less. If lower pressure rated components cannot be removed or isolated, the maximum test pressure is the pressure rating of the lowest pressure rated component that cannot be isolated from the test section. Leak test pressure is temperature dependent and must be reduced at elevated temperatures.
- The pressure in the test section should be gradually increased to not more than one-half of the test pressure; then increased in small increments until the required leak test pressure is reached. Leak test pressure should be maintained for ten (10) to sixty (60) minutes; then reduced to the design pressure rating (compensating for temperature if required), and maintained for such time as required to examine the system for leaks.
- Leaks may be detected using mild soap solutions (strong detergent solutions should be avoided), or other non-deleterious leak detecting fluids applied to the joint. Bubbles indicate leakage. After leak testing, all soap solutions or leak detecting fluids should be rinsed off the system with clean water.
- If leaks are discovered, depressurize the test section before repairing leaks. Correctly made fusion joints do not leak. *Leakage at a butt fusion joint may indicate imminent catastrophic rupture. Depressurize the test section immediately if butt fusion leakage is discovered.* Leaks at fusion joints require the fusion to be cut out and redone.
- If the pressure leak test is not completed due to leakage, equipment failure, etc., the test section should be de-pressurized and repairs made. Allow the test section to remain depressurized for at least eight (8) hours before retesting.

### Pressure System Leak Testing – Initial Service

An initial service leak test may be acceptable when other types of tests are not practical, or where leak tightness can be demonstrated by normal service, or when initial service tests of other equipment are performed. An initial service test may

apply to systems where isolation or temporary closures are impractical, or where checking out pumps and other equipment affords the opportunity to examine the system for leakage prior to full scale operations.

- *Restraint* – The pipeline section to be tested must be restrained against movement in the event of catastrophic failure. Joints may be exposed for leakage examination provided that restraint is maintained.

Test equipment and the pipeline should be examined before pressure is applied to ensure that connections are tight, necessary restraints are in place and secure, and components that should be isolated or disconnected are isolated or disconnected. All low pressure filling lines and other items not subject to the test pressure should be disconnected or isolated.

- *Leak test fluid* – The initial service leak test fluid will usually be the liquid or gas being transported in the pipeline. The leak test fluid may or may not need to be purged or flushed from the system.
- *Leak Test Pressure* – The piping system should be gradually brought up to normal operating pressure, and held at operating pressure for at least ten (10) minutes. During this time, joints and connections should be examined for leakage.
- If leaks are discovered, depressurize the test section before repairing leaks. Correctly made fusion joints do not leak. Leaks at fusion joints require the fusion to be cut out and redone. *Leakage at a butt fusion joint may indicate imminent catastrophic rupture. Depressurize the test section immediately if butt fusion leakage is discovered.*

### Non-Pressure System Leak Testing

Pressure testing of non-pressure systems such as sewer lines should be conducted in accordance with ASTM F 1417<sup>(9)</sup>.

### Non-Testable Systems

Some systems may not be suitable for pressure leak testing. These systems may contain non-isolatable components, or temporary closures may not be practical. Such systems should be carefully inspected during and after installation. Inspections such as visual examination of joint appearance, mechanical checks of bolt or joint tightness, and other relevant examinations should be performed.

## Considerations for Post Start-Up and Operation

### Disinfecting Water Mains

Applicable procedures for disinfecting new and repaired potable water mains are presented in standards such as ANSI/AWWA C651<sup>(10)</sup> that uses liquid chlorine,

sodium hypochlorite, or calcium hypochlorite to chemically disinfect the main. Disinfecting solutions containing chlorine should not exceed 12% active chlorine, because greater concentration can chemically attack and degrade PE.

## Cleaning

Pipelines operating at low flow rates (around 2 ft/sec or less) may allow solids to settle in the pipe invert. PE has a smooth, non-wetting surface that resists the adherence of sedimentation deposits. If the pipeline is occasionally subject to higher flow rates, much of the sedimentation will be flushed from the system during these peak flows. If cleaning is required, sedimentation deposits can usually be flushed from the system with high pressure water.

Water-jet cleaning is available from commercial services. It usually employs high pressure water sprays from a nozzle that is drawn through the pipe system with a cable.

Pressure piping systems may be cleaned with the water-jet process, or may be pigged. Pigging involves forcing a resilient plastic plug (soft pig) through the pipeline. Soft pigs must be used with PE pipe. Scraping finger type or bucket type pigs may severely damage a PE pipe and must not be used. Usually, hydrostatic or pneumatic pressure is applied behind the pig to move it down the pipeline. Pigging should employ a pig launcher and a pig catcher.

A pig launcher is typically a tee assembly or a removable spool. In the tee assembly, the main flow is into the tee branch and out through a run outlet. The opposite tee run outlet is used to launch the pig. The pig is fitted into the opposite tee run; then the run behind the pig is pressurized to move the pig into the pipeline and downstream. In the removable pipe spool, the pig is loaded into the spool, the spool is installed into the pipeline, and then the pig is forced downstream. (Note – Fully pressure rated wyes suitable for pig launching are generally not available.)

*A pig may discharge from the pipeline with considerable velocity and force. The pig catcher is a basket or other device at the end of the line to safely receive or catch the pig when it discharges from the pipeline.*

## Squeeze-Off

Squeeze-off (or pinch-off) is a means of controlling flow in smaller diameter PE pipe and tubing by flattening the pipe between parallel bars. Flow control does not imply complete flow stoppage in all cases. For larger pipes, particularly at higher pressures, some seepage is likely. If the situation will not allow seepage, then it may be necessary to vent the pipe between two squeeze-offs.



PE gas pipe manufactured to ASTM D 2513<sup>(11)</sup> is suitable for squeeze-off; however, squeeze-off practices are not limited to gas applications. Squeeze-off is applicable to PE pressure pipe up to 16" IPS, and up to 100 psi internal pressure, and conveying various gases or liquids. Larger sizes and higher pressures may be possible if suitable commercial equipment is available. Manufacturers of squeeze-off equipment should be consulted for equipment applicability, availability and capabilities.

*Squeeze-off is applicable ONLY to PE pipe and tubing. The pipe or tubing manufacturer should be consulted to determine if squeeze-off is applicable to his product, and for specific squeeze-off procedures.*

Squeeze-off tools should comply with ASTM F 1563<sup>(12)</sup>. Typical squeeze-off tools use a manual mechanical screw or hydraulic cylinders, incorporate gap stops to prevent over-squeeze, and a mechanism to prevent accidental bar separation.

Closing and opening rate are key elements to squeezing-off without damaging the pipe. It is necessary to close slowly and release slowly, with slow release being more important. Squeeze-off procedures should be in accordance with ASTM F 1041<sup>(13)</sup> and should be qualified in accordance with ASTM F 1734<sup>(14)</sup>.

Lower temperatures will reduce material flexibility and ductility, so in colder weather, closure and opening time must be slowed further.

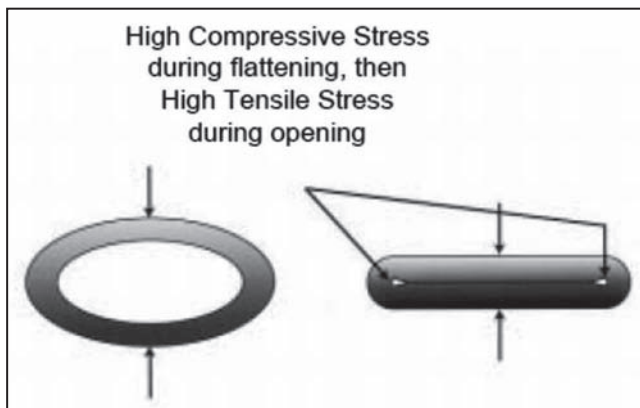

**Figure 8** Squeeze-Off Stress

Testing of PE piping has shown that squeeze-off can be performed without compromising the expected service life of the system, or pipe can be damaged during squeeze-off. Damage occurs:

- If the manufacturer's recommended procedures are not followed, or
- If the squeeze is held closed too long, or

- From static electric discharge, or
- When closure stops are altered or circumvented, or
- By squeezing-off more than once in the same location.

*Pipe known or suspected to have been damaged during squeeze-off should be removed from the system, or should be reinforced at the squeeze-off point using a full encirclement clamp and replacement repair scheduled.*

*Static Electricity Control* – When pipe conveying a compressed gas is being flattened, the gas flow velocity through the flattened area increases. High velocity, dry gas, especially with particles present in the flow, can generate a static electric charge on pipe surfaces that can discharge to ground. *Before flattening the pipe, the tool should be grounded and procedures to control static charge build-up on pipe surfaces such as wetting surfaces with conductive fluids and applying conductive films or fabrics to ground should be employed.* Grounding and static control procedures should remain in place for the entire squeeze-off procedure.

Identify the squeezed-off area by wrapping tape around the pipe, or installing a full encirclement clamp over the area.

Squeeze-off procedures may be used for routine, scheduled changes to piping systems, or as an emergency procedure to control gasses or liquids escaping from a damaged pipe. For scheduled piping changes, ASTM F 1041 procedures that are qualified per ASTM F 1734 should be observed so that the pipe's service life is not compromised.

However, an emergency situation may require quickly flattening the pipe and controlling flow because the escaping fluid may be an immediate hazard of greater concern than damaging the pipe. *If an emergency situation requires rapid flattening, the pipe or tubing may be damaged.* When the emergency situation is resolved, a full encirclement clamp should be installed over the squeezed off area, and repair to replace the damaged pipe should be scheduled.

## **Conclusion**

A successful piping system installation is dependent on a number of factors. Obviously, a sound design and the specification and selection of the appropriate quality materials are paramount to the long term performance of any engineered installation. The handling, inspection, testing, and safety considerations that surround the placement and use of these engineered products is of equal importance.

In this chapter, we have attempted to provide fundamental guidelines regarding the receipt, inspection, handling, storage, testing, and repair of PE piping products.

While this chapter cannot address all of the product applications, test and inspection procedures, or construction practices, it does point out the need to exercise responsible care in planning out these aspects of any job site. It is the responsibility of the contractor, installer, site engineer, or other users of these materials to establish appropriate safety and health practices specific to the job site and in accordance with the local prevailing codes that will result in a safe and effective installation.

## References

1. PPI Material Handling Guide, Plastics Pipe Institute, Irving, TX.
2. ASTM F 894 Standard Specification for Polyethylene (PE) Large Diameter Profile Wall Sewer and Drain Pipe, ASTM, West Conshohocken, PA.
3. Gilroy, H.M., "Polyolefin Longevity for Telephone Service", Antec Proceedings, 1985.
4. PPI TN-36 General Guidelines for Connecting HDPE Potable Water Pressure Pipes to DI and PVC Piping Systems, Plastics Pipe Institute, Irving, TX.
5. PPI TR-19, Chemical Resistance of Thermoplastics Piping Materials, Plastics Pipe Institute, Irving, TX.
6. ASTM D 638 Standard Test Method for Tensile Properties of Plastics, ASTM, West Conshohocken, PA.
7. ASTM F 2634 Standard Test Method for Laboratory Testing of Polyethylene (PE) Butt Fusion Joints using Tensile-Impact Method, ASTM, West Conshohocken, PA.
8. ASTM F 2164 ASTM Standard Practice for Field Leak Testing of Polyethylene (PE) Pressure Piping Systems Using Hydrostatic Pressure, West Conshohocken, PA.
9. ASTM F 1417 Standard Test Method for Installation Acceptance of Plastic Gravity Sewer Lines Using Low Pressure Air, ASTM, West Conshohocken, PA.
10. AWWA C651 Standard for Disinfecting Water Mains, AWWA, Denver, CO
11. ASTM D 2513 Standard Specification for Thermoplastic Gas Pressure Pipe, Tubing and Fittings, ASTM, West Conshohocken, PA.
12. ASTM F1563, Standard Specification for Tools to Squeeze-off Polyethylene (PE) Gas Pipe or Tubing, West Conshohocken, PA.
13. ASTM F1041, Standard Guide for Squeeze-off of Polyethylene Gas Pressure Pipe or Tubing, West Conshohocken, PA.
14. ASTM F 1734 Standard Practice for Qualification of a Combination of Squeeze Tool, Pipe, and Squeeze-Off Procedures to Avoid Long-Term Damage in Polyethylene (PE) Gas Pipe, ASTM, West Conshohocken, PA.