

# 6" Ultra Slim LED Square Panel Light with 5-CCT Switch

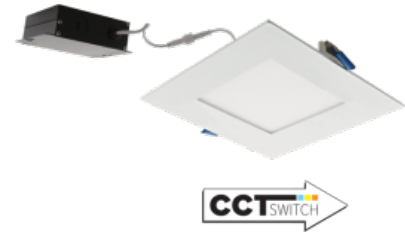

These unique 6" ultra slim panel light designed for quick and easy installation without a housing for both new construction and remodel applications, gives you the options you are looking for in one fixture. The manual switch allows you to choose between 2700K, 3000K, 3500K, 4000K or 5000K. This IC Rated fixture can be installed indoor or outdoors.

## Features

- IC Airtight for use with direct contact to insulation.
- Designed to fit in plenums as shallow as 2".
- Eliminates the need for housing.
- New Construction application requires mounting plate or frame.
- Remodel applications require no additional accessories.
- Wet Location allows for use indoors or outdoors.
- CA Title 24 and ENERGY STAR Compliant.
- Includes driver and Jbox.

## Specifications

<b>Wattage</b>	12W
<b>Lumens</b>	700 lm
<b>Voltage</b>	120V
<b>Color Temp.</b>	2700K, 3000K, 3500K, 4000K, 5000K
<b>Dimmable</b>	Triac/ELV
<b>Lamp Type</b>	LED
<b>CRI</b>	90+
<b>Wet Location</b>	Listed

## Dimensions

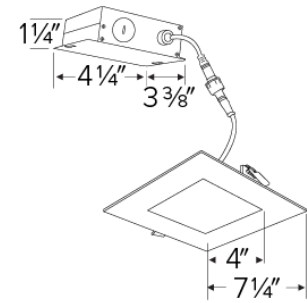

## Technical Details

**Optics:** Polycarbonate lens diffuses light evenly throughout space with no LED pixelation.

**Construction:** IC rated driver and fixture are tested and approved for direct contact with insulation. Aluminum die-cast trim ring with durable powdercoat finish preventing rust and paint cracking. Plenum rated cable connector to connect from module to remote driver box. Isolated driver integrated inside aluminum remote box with two 7/8" knockouts with slots for pryout.

**Installation:** Designed for super shallow ceiling plenums without any housing. High strength steel spring clip for easy installation. Hole cut out template provided for accurate hole size for proper trim installation. Maximum hole size should not exceed 4 1/4" for this product. Suitable installation for t-grid and drop ceiling applications.

**Electrical:** Driver connects directly to 120V power supply. Standard input wattage is 9W, 55 lumens per watt. Replaces 50W incandescent.

**Dimmability:** Works with 120V Triac and ELV type dimmers. Dims down to 10%. For full list of dimmers, refer to the ELM System Dimmer Compatibility List.

**Listings:** ETL Listed for Wet Locations. Meets ENERGY STAR® requirements. IC-Rated for direct contact with insulation. California Title 24 Compliant.

**Warranty:** 5-year limited warranty.

## Product Numbers

Item	Lamp type	Lumens	CCT	Watts	Voltage	Dimming	Finish
ERT661CT5W	LED	700 lm	2700K, 3000K, 3500K, 4000K, 5000K	12W	120V	Triac/ELV	White

## Product Number Builder Example: ERT661CT5W

6" Ultra Slim LED Panel Light	Wattage/Lumen	Color Temp.	Finish
ERT6	61 12W / 700 lm	CT5 2700K - 5000K	W White

# Compatible Products

For use with 6" Elm™ System Slim Panels



## 6" Elm™ New Construction Frames

---



Frame with Hanger Bars  
**New Construction**

CAT NO.	SPECIFICATIONS
E6LF1 (6")	9" L x 6 3/4" W x 6 1/4" Opening



Square Mounting Plates  
**New Construction**

CAT NO.	SPECIFICATIONS
EMPSQ6 (6" Square)	17 1/4" L x 8 3/8" W x 6" Sq.



Universal Frame for 2", 4" and 6" Downlights  
**New Construction**

CAT NO.	SPECIFICATIONS
E246LF1	12 1/8" L x 7 5/8" W