



STINGER

Refrigerant Recovery Unit
High Performance • Oilless • Commercial



User Manual
2090-0217 Rev. 6
April 2012

Congratulations on your purchase of the STINGER high-performance oilless recovery unit. Bacharach has worked hard to make the STINGER the highest performing, most portable, and easiest-to-use recovery unit on the market. We are committed to your complete satisfaction.

WARRANTY

Bacharach warrants this product for 1 year from the date of purchase indicated on the original sales receipt. The warranty covers all parts within the unit, but excludes damage to the unit caused by misuse or mishandling. The unit's motor brushes carry an extended warranty of 5 years.

If the unit is in need of warranty service within 1 year of its date of purchase, it will be replaced with a brand new one via our over the counter (OTC) exchange program. To obtain a warranty replacement unit via the OTC exchange program, the following steps must be followed:

- 1) Return the unit to the wholesaler from whom it was purchased, along with proof of purchase (original or copy of sales receipt).
- 2) If the wholesaler determines the unit is eligible for OTC exchange, it will be replaced with a brand new one. If the failure is determined to have been caused by customer misuse or mishandling, the warranty will be voided.
- 3) The wholesaler should then contact our Customer Service Department for a return goods authorization (RGA) in order to return the defective unit and have an order entered for its replacement. Proof of purchase will be required in order to process the RGA. OTC exchange units are processed as no charge orders.

If you have any questions, please contact our Customer Service Department at 800-736-4666 or email them at help@mybacharach.com.

Copyright © 2012, Bacharach, Inc.
All rights reserved.

BACHARACH® is a registered trademark of Bacharach, Inc. All other trademarks, trade names, service marks and logos referenced herein belong to their respective owners.

Table of Contents

Safety4

Specifications7

Descriptions of Features.....9

Vapor/Liquid Recovery Operations 13

Standard Recovery Hose Connections 14

Liquid Push-Pull Recovery Operations 16

Liquid-Pull Recovery / Charging Method..... 19

R-410A Recovery – Special Notes 20

Purging the STINGER 22

DOT Recovery Cylinder Safety 23

Recovery Tips 25

Troubleshooting..... 27

Schematic Diagram 30

STINGER Parts List..... 31

Compressor Parts List 33

Declarattion of Conformity 35

Safety



CAUTION! Before operating this unit, please read this manual in its entirety. It is important that you have a thorough understanding of the procedures outlined in this manual. Failure to follow these procedures could void all manufacturer warranties.



WARNING! This unit is capable of over-pressurizing a DOT recovery cylinder. Ensure that you are using the proper DOT recovery cylinder for the refrigerant that you are recovering. NOTE: R-410 is capable of pressures exceeding 600 psi. Typical DOT recovery cylinders are rated at 350 psi with a pressure relief set at 550 psi. These cylinders should not be used with R-410A. Only cylinders rated at 400 psi with the relief valve setting at 600 psi should be used to for R-410A. Failure to use the proper cylinder can be extremely dangerous.



BEFORE handling refrigerants, read the material safety data sheet from the refrigerant manufacturer.



CAUTION! These instructions are for personnel trained and experienced in the handling of refrigerants. Unqualified individuals should not attempt to operate this equipment. Failure to follow proper operating procedures may cause personal injury.



WARNING! Inhalation of high concentrations of refrigerant vapors is harmful and may cause heart irregularities, unconsciousness, or death. Deliberate inhalation of refrigerants is extremely dangerous and death can occur without warning. Vapors reduce oxygen available for breathing and are heavier than air. Decomposition products are hazardous. Liquid contact may cause frostbite. All refrigerant containers, equipment, and hoses are under pressure.



HAZARDOUS AREA WARNING: This instrument has not been designed to be intrinsically safe for use in areas classified as hazardous locations. DO NOT use it in hazardous (classified) locations.



COMBUSTIBLE/FLAMMABLE GAS WARNING: For your safety, DO NOT use this device to recover refrigerants which are rated as combustible/flammable gases (e.g. ASHRAE - A2 or A3 rated refrigerants).



WARNING: Inhalation of high concentrations of refrigerant vapors is harmful and may cause heart irregularities, unconsciousness, or death. Deliberate inhalation of refrigerants is extremely dangerous and may cause death. Vapor reduces the oxygen available for breathing and is heavier than air. Decomposition products are hazardous. Liquid contact can cause frostbite. All refrigerant containers, equipment, and hoses are under high pressure.



WARNING: Before starting the unit you MUST OPEN the outlet port on the Stinger and open the port to the recovery tank. Read entire operating instruction manual before use. Failure to open the outlet port will cause permanent damage to the unit and void the warranty.



CAUTION: All refrigerant hoses, recovery tanks, refrigerant lines, the STINGER unit, and other vessels containing refrigerants should be handled at all times as if under high pressure.



GENERAL SAFETY GUIDELINES:

- Avoid breathing high concentrations of vapors.
- Use with sufficient ventilation to keep operator exposure below recommended limits, especially in enclosed and low lying areas.
- Avoid contact of liquid with eyes and prolonged skin exposure.
- Wear safety goggles and protective gloves.
- Make sure the power switch is in the OFF position before plugging this equipment into an AC power source.
- Unplug unit before servicing; otherwise, an electrical shock hazard will be present when the unit is disassembled.
- Use caution when connecting or disconnecting hoses. Improper usage may result in refrigerant burns (frostbite). If a significant refrigerant leak occurs, proceed immediately to a well-ventilated area.
- Do not apply open flame or heat unit above 125 °F.

-
- Do not allow refrigerants to contact open flame. Decomposition will occur. Inhalation of decomposition is harmful.
 - **First Aid:**
 - Inhalation: If high concentrations of refrigerant vapors are inhaled, immediately remove the person(s) to fresh air. Keep calm. If not breathing, give artificial respiration. If breathing is difficult, give oxygen. Call a doctor. Do not give epinephrine or similar drugs.
 - Eye Contact: In case of liquid contact, immediately flush eye with water. Seek medical attention.
 - Skin Contact: Flush with water. Treat for frostbite by gently warming the affected area.
 - **Know your equipment:** Read and understand the User Manual and labels affixed to the unit. Learn the application and limitations as well as the specific potential hazards of your equipment.
 - **Ground all equipment:** Stinger is equipped with a three-pronged grounded power cord.
 - **Use the proper extension cord:** Keep extension cord length to a minimum. Use the following guide for choosing the proper extension cord:
 - 18 gauge cord – maximum length 10 feet
 - 16 gauge cord – maximum length 25 feet
 - 14 gauge cord – maximum length 50 feet
 - 12 gauge cord – maximum length 100 feet
 - **Use approved hoses:** Use refrigerant connection hoses that are approved to SAE J2196-1992. These hoses must provide a shut-off device within 12 inches of the ends, and must be approved for outdoor usage.
 - **Use approved recovery tank:** Use a DOT approved refrigerant recovery tank made for use with the type of refrigerant being recovered. Note that R-410 is capable of pressures exceeding 600 psi. Typical DOT recovery cylinders are rated at 350 psi with a pressure relief set at 550 psi. These cylinders should not be used with R-410A. Only cylinders rated at 400 psi with the relief valve setting at 600 psi should be used to for R-410A. Failure to use the proper cylinder can be extremely dangerous!

- **Use weight (charging) scale:** A scale (P/N 2010-0000) must be used to indicate when the recovery tank is 80% full when the STINGER does not have the 80% Shutoff Kit option installed.
- **Avoid dangerous environments:** Although the unit can be used outdoors, we do not recommend operation in the rain, or in wet locations. Secure the unit when working above floor level. This equipment should not be used in the vicinity of spilled or open containers of flammable materials.
- **Ventilation requirements:** This equipment should be used in a location with mechanical ventilation that provides at least 4 air changes per hour, or the equipment should be located at least 18" above the floor.
- **Use recommended accessories:** Follow the instructions that accompany all accessories. Improper use of accessories may damage the equipment or create a hazard.
- **Repair damaged parts:** Do not operate the unit with a defective part. Repair unit to proper operating conditions.

Specifications

Refrigerant Recovery Rates - Certified per AHRI 740-95 & 740-98				
Refrigerant	Liquid Rate	Liquid Rate (Push-Pull)	Vapor Rate	Vacuum Level (inches Hg)
R-22	3.53 lb/min 1.60 kg/min	12.30 lb/min 5.58 kg/min	0.29 lb/min 0.13 kg/min	>15
R-134A	2.67 lb/min 1.21 kg/min	10.98 lb/min 4.98 kg/min	0.22 lb/min 0.10 kg/min	>15
R-410A	3.02 lb/min 1.37 kg/min	14.62 lb/min 6.63 kg/min	0.22 lb/min 0.10 kg/min	>15

Specification	Description
Compatible Refrigerants	R-12, R-22, R-114, R-134a, R-401A, R-401B, R-401C, R-402A, R-402B, R-404A, R-406A, R-407A, R-407B, R-407C, R-407D, R-408A, R-409A, R-410A, R-411A, R-411B, R-412A, R-500, R-502, R-507, R-509
Power	<ul style="list-style-type: none"> • 110/120 VAC, 1 Phase, 50/60 Hz, 8 A • 230 VAC, 1 Phase, 50/60 Hz, 5 or 10 A • 240 VAC, 1 Phase, 50/60 Hz, 5 A (See label on back of unit)
Compressor	¾ HP High Performance Oilless
Cooling	Two Cooling Fans
Protection	High pressure cutoff at 550 psi. Compressor is protected by circuit breakers and internal compressor thermal sensor. Optional 80% tank full shutoff kit (P/N 2090-0091).
Pressure Ratings	Low Side design pressure 450 PSI High Side design pressure 550 PSI
Temperature	Operating Range 32 to 104 °F (0 to 40 °C)
Case	Blow-Molded, High Impact Polyethylene
Size (LxWxH)	17" x 9.5" x 11" (43.2 cm x 24.1 cm x 27.9 cm)
Weight	28 Lbs (12.7 kg)
Certification	Complies with UL1963 (not evaluated for automotive use)

Descriptions of Features

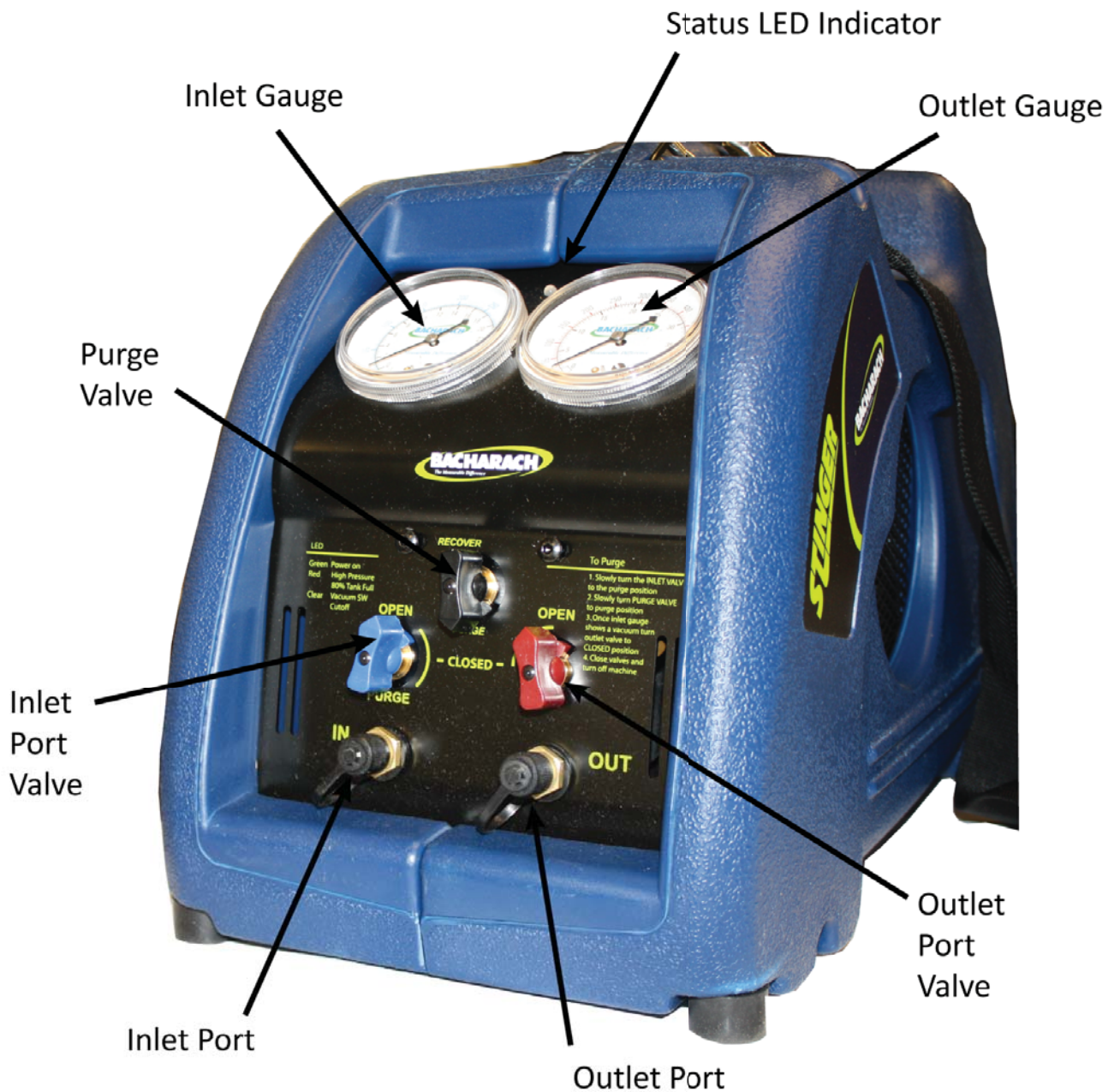

Figure 1. Stinger Front View

Front View Components

Component	Description
Status LED Indicator	<u>Green:</u> Normal operation. <u>Red:</u> Tank is 80% full or 550 psi pressure limit is reached (shut down condition). <u>Clear:</u> Vacuum condition has reached 13" Hg (shut down condition).
Inlet Gauge	Displays the inlet/suction pressure of the system being evacuated.
Outlet Gauge	Displays the outlet/discharge pressure.
Purge Valve	This valve determines what function the STINGER performs. This valve is UP during recovery operations and DOWN for purging and liquid push-pull operations.
Inlet Port Valve	Opens or closes the inlet port. Points UP (open) for all recovery operations and points DOWN for purging operations.
Outlet Port Valve	Opens or closes the outlet port. Points UP when open, and to the left when CLOSED.
Inlet Port	Refrigerant hose connection for incoming refrigerant.
Outlet Port	Refrigerant hose connection for outgoing refrigerant.

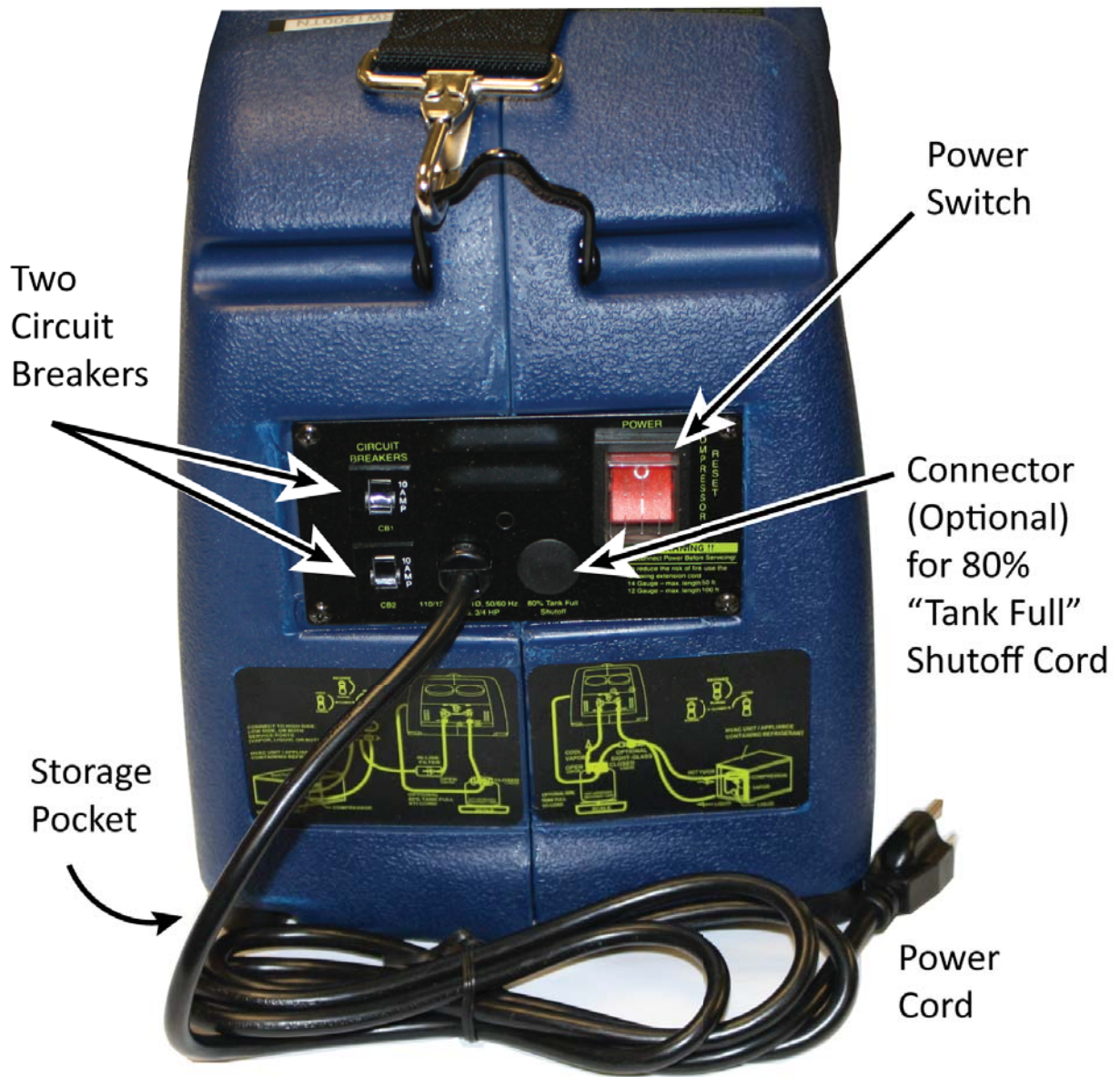

Figure 2. Stinger Rear View

NOTE: If the "Tank Full" Shutoff Cord option is installed, the STINGER will not operate unless it is connected to a recovery cylinder with a compatible level-float switch. If the recovery cylinder doesn't have a float switch, a shorting cap must be installed on the shutoff cord.

Rear View Components

Component	Description
Power Switch	When in the ON position, this switch starts the recovery operation by turning ON the compressor.
Two Circuit Breakers	Protects the STINGER from over current.
Connector for optional 80% tank full shutoff cord	This optional accessory (Part Number 2090-0091) connects to a DOT recovery cylinder's overfill sensor. It automatically shuts the STINGER off when the recovery cylinder reaches 80% of its liquid-fill limit.
Storage Pocket	This heavy-duty storage pocket is used to store the Operation Manual, the Warranty Card and the original invoice. These items should be kept with the unit at all times.
Power Cord	230 VAC units have a male IEC 60320 type plug that requires the use of a customer-supplied power-cord adapter.

Vapor/Liquid Recovery Operations

Perform the following steps when recovering refrigerant that is either in vapor or liquid form.

NOTE: Refer to “R-410A Recovery – Special Notes” on page 20 when recovering R-410A.

1. Turn off all electrical or mechanical power to the refrigerant device to be evacuated.
2. Make proper hose connections. Connect refrigerant hoses to recovery cylinder, STINGER, and A/C system as shown on page 15. When possible, use a manifold-gauge set to recover refrigerant from both the high- and low-side service ports. This will speed up the recovery rates.



CAUTION: If the 80% tank full shutoff cord is *not* used, then use a scale (P/N 2010-0000) to monitor the refrigerant level in the recovery cylinder in order to prevent overfilling.



CAUTION: When recovering R-410A, you must use a recovery cylinder approved for use with R-410A. ***Standard recovery cylinders with 350 psi working pressures are not approved for use with R-410A.***

3. Turn the inlet valve to the “CLOSED” position, the outlet valve to the “OPEN” position, and the PURGE valve to the “RECOVER” position. Open the vapor valve on the DOT recovery tank.
4. Use the rear mounted power switch to turn ON the STINGER.

NOTE: When recovering liquid, in rare instances a “knocking” sound may come from the compressor. This indicates that too much liquid is entering the compressor. The inlet valve must be regulated (closed) until this knocking sound stops, otherwise compressor damage could occur. Pumping liquid when the compressor is knocking will damage the compressor, reduce the compressor life, ***and void the compressor’s warranty.*** This condition is rare and should not occur under normal recovery operations.

-
5. Slowly open the inlet valve until the Stinger's compressor turns on. Continue to slowly regulate the inlet valve to the full open position.



WARNING: If the compressor begins to “knock,” regulate the inlet valve toward the closed position until the knocking stops. ***Failure to do so could void the compressor’s warranty.***

6. Proceed with the recovery process until the system pressure shows a vacuum. Turn OFF the STINGER for a minimum of 5 minutes; after which, determine the amount of refrigerant remaining in the system. Repeat this step until system pressure is below mandatory EPA levels.
7. Purge the STINGER as follows:
 - a. Turn OFF the STINGER.
 - b. Turn the inlet and purge valves to their “PURGE” position (both pointing DOWN), and the outlet valve to its “OPEN” position (pointing UP).
 - c. Turn ON the STINGER and monitor the inlet gauge. The purge operation is complete when the inlet pressure gauge shows a vacuum.

Standard Recovery Hose Connections

IMPORTANT NOTES FOR LIQUID RECOVERY

The Stinger can be used for pumping virgin refrigerant on an intermittent basis. Unlike recovered refrigerant, virgin refrigerant does not contain oil.



CAUTION: Routinely pumping virgin refrigerant through the STINGER can remove lubrication from the compressor, resulting in premature failure. Use the liquid push-pull method or the liquid-pull method to transfer large amounts of liquid refrigerant (virgin or dirty).



ATTENTION: You **must** use an agency-approved in-line filter when recovering liquid. Contaminants (particularly from the bottom of recovery cylinders) can enter the STINGER and become lodged in the valve seats causing damage and resulting in leaks. We recommend using Bacharach in-line filter P/N 07-1700 to guarantee optimum pumping speed.

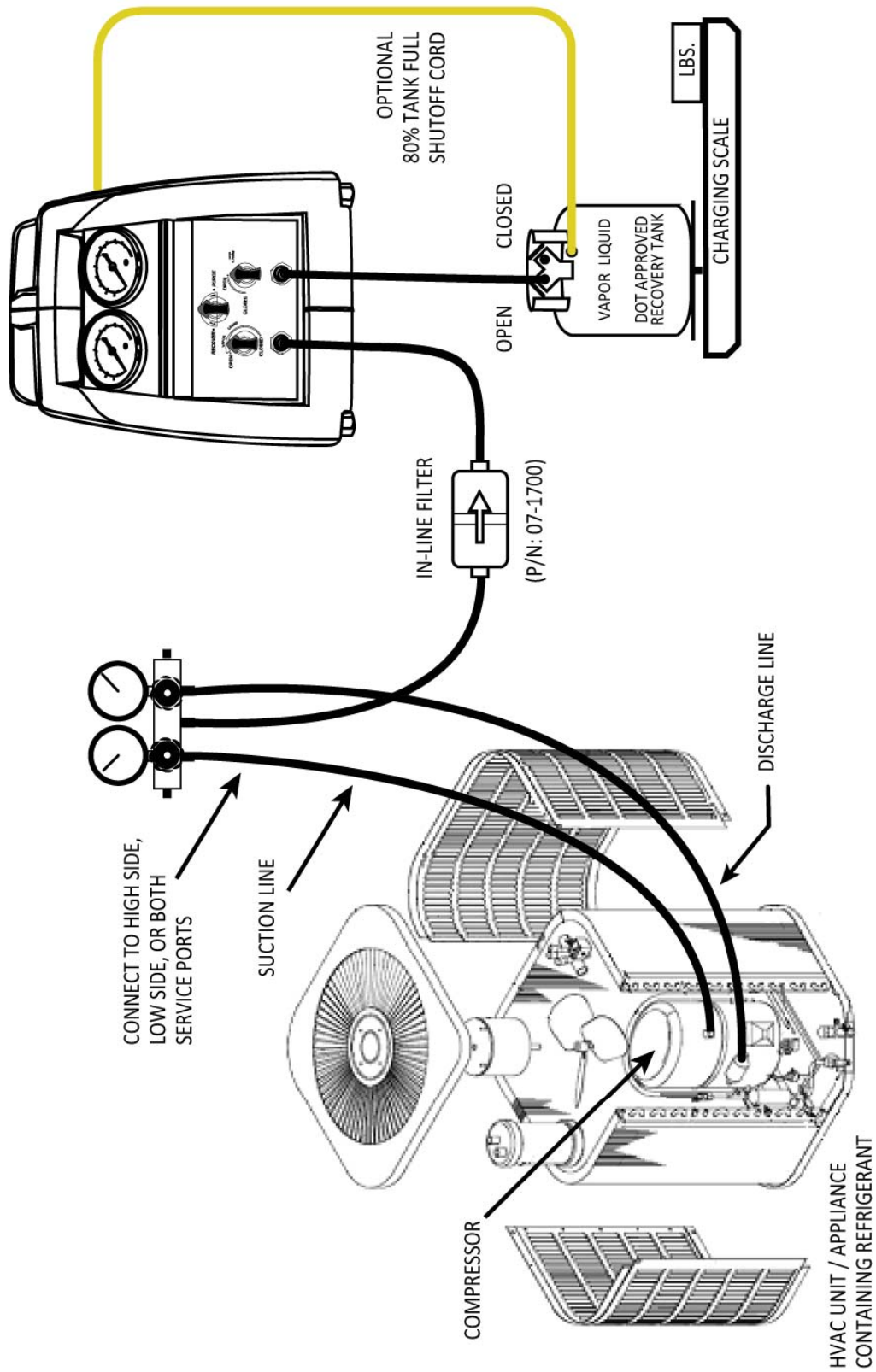

Figure 3. Standard Recovery Hose Connections

Liquid Push-Pull Recovery Operations



ATTENTION: Before attempting liquid push-pull recovery operations, please review this page.

A scale or liquid-sight glass can be used to determine when all the liquid is recovered. The STINGER will not pull a vacuum using the liquid push-pull recovery operation. To finish the recovery operation, you must perform vapor recovery operations as described on page 13.

GUIDELINES

If *any* of the following conditions are present in the system being evacuated, the liquid push-pull operations may not be practical and vapor recovery operations should be performed.

- ✓ The equipment contains less than 20 lbs of refrigerant.
- ✓ The equipment is a heat pump or other system with refrigerant flow that would prevent you from isolating the liquid.
- ✓ Equipment has an accumulator between the service ports used in the liquid recovery process.
- ✓ Liquid refrigerant migration has occurred and the location of the liquid is unknown.
- ✓ The refrigerant tubing design on the equipment does not allow for a solid column of liquid refrigerant to be formed.

STEPS

The liquid push-pull recovery method requires the use of a third hose. In addition, a sight-glass is useful for determining when all of the liquid has been pushed out of the system. After all the liquid has been pushed out, you will need to reconfigure the hoses for vapor recovery since the liquid push-pull recovery method does not pull a vacuum on the system.

1. Remove power from the refrigerant device to be evacuated.
2. Make proper hose connections for liquid push-pull recovery as shown in Figure 4.



CAUTION: If the 80% tank full shutoff cord is *not* used, then use a scale to monitor the refrigerant level in the recovery cylinder in order to prevent overfilling.



CAUTION: When recovering R-410A, you must use a recovery cylinder approved for use with R-410A. ***Standard recovery cylinders with 350 psi working pressures are not approved for use with R-410A.***

3. Turn the inlet and outlet valves to their “OPEN” position and the PURGE valve to its “PURGE” position.

NOTE: The “PURGE” position bypasses the condenser, optimizing the push-pull flow rate.

4. Open both the vapor and liquid valves on the DOT recovery tank.
5. Turn ON the STINGER. The compressor will begin to “pull” vapors from the cylinder and “push” the liquid out of the system and into the recovery cylinder.
6. If a sight-glass is being used, you should watch it to determine when all of the liquid has been removed from the system.
7. The liquid push-pull recovery method will not pull a vacuum in the system. You must turn OFF the STINGER and reconfigure the hoses for vapor recovery operations as described on page 13.

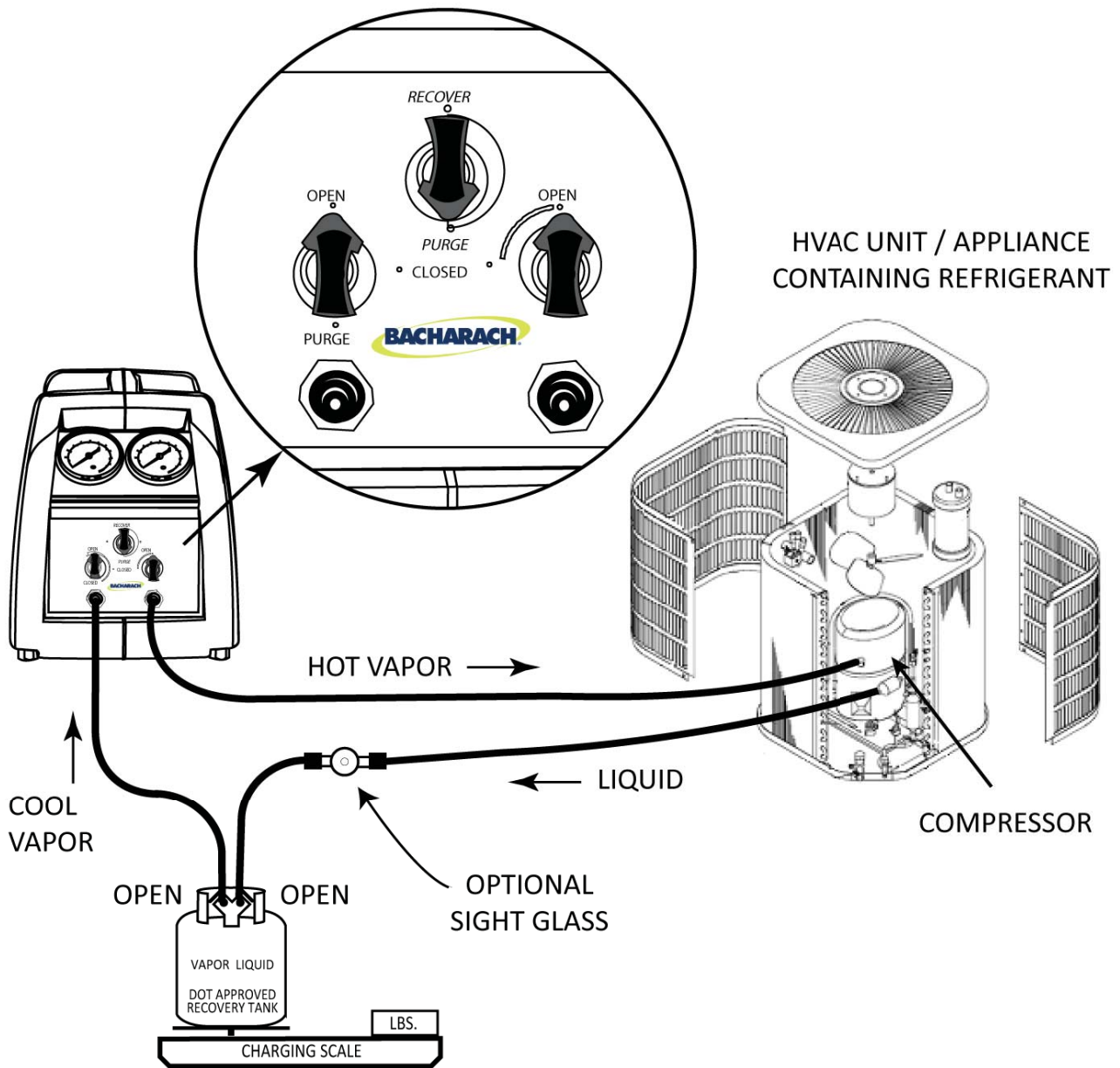

Figure 4. Liquid Push/Pull Recovery Operation

Liquid-Pull Recovery / Charging Method

The Stinger can be used for pumping virgin refrigerant on an intermittent basis. Unlike recovered refrigerant, virgin refrigerant does not contain oil.



CAUTION: Routinely pumping virgin refrigerant through the STINGER can remove lubrication from the compressor, resulting in premature failure. Use the liquid push-pull method or the liquid-pull method to transfer large amounts of liquid refrigerant (virgin or dirty).

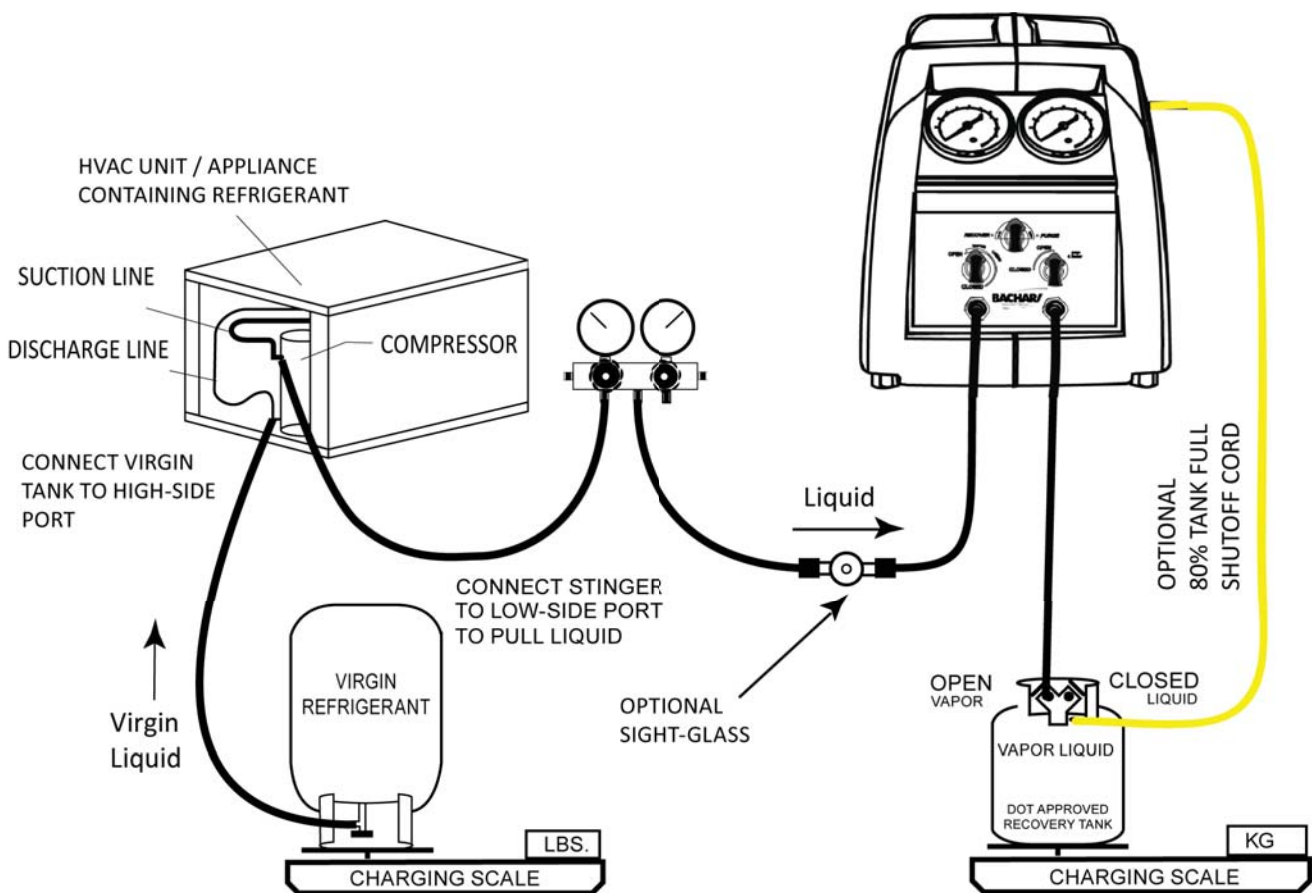

Figure 5. Liquid Pull Recovery/Charging Operation

The liquid-pull method is used to move a large amount of liquid refrigerant without the refrigerant passing directly through the STINGER. The virgin refrigerant is pulled directly into the system being charged. The STINGER keeps the pressure low in the system by removing vapor. For every pound of vapor removed, as much as 25 pounds of liquid refrigerant may be transferred. This method can be used for either virgin refrigerant or really dirty refrigerant.

R-410A Recovery – Special Notes

R-410A is a replacement refrigerant for R-22. Its physical properties, however, are much different than R-22. R-410A has a higher vapor pressure and is more dense than R-22. These characteristics make recovering R-410A more difficult by putting more of a load on the compressor. Please follow the instructions below to ensure trouble-free R-410A recovery.

NOTE: Hose connections are the same for recovering R-410A. Connect hoses as shown in the vapor recovery diagram below.

Under normal operating conditions the STINGER can recover R-410A just like R-22. Under certain conditions, however, because of R-410A's higher vapor pressure and density, you will have to take the following precautions:



CAUTION: USE ONLY DOT RECOVERY CYLINDERS APPROVED FOR USE WITH R-410A. Overfilling or over-pressurizing your recovery cylinder is extremely dangerous.

WHEN RECOVERING VAPOR: If the STINGER sounds like it is overloaded either by slowing down or by making a “knocking” sound, reduce the inlet pressure by closing or “throttling” the inlet valve until the STINGER begins to run normally.

WHEN RECOVERING LIQUID: If a loud knocking noise occurs, the inlet pressure on the STINGER should be throttled back by slowly closing the inlet valve until the knocking noise stops. This action will prevent compressor damage.

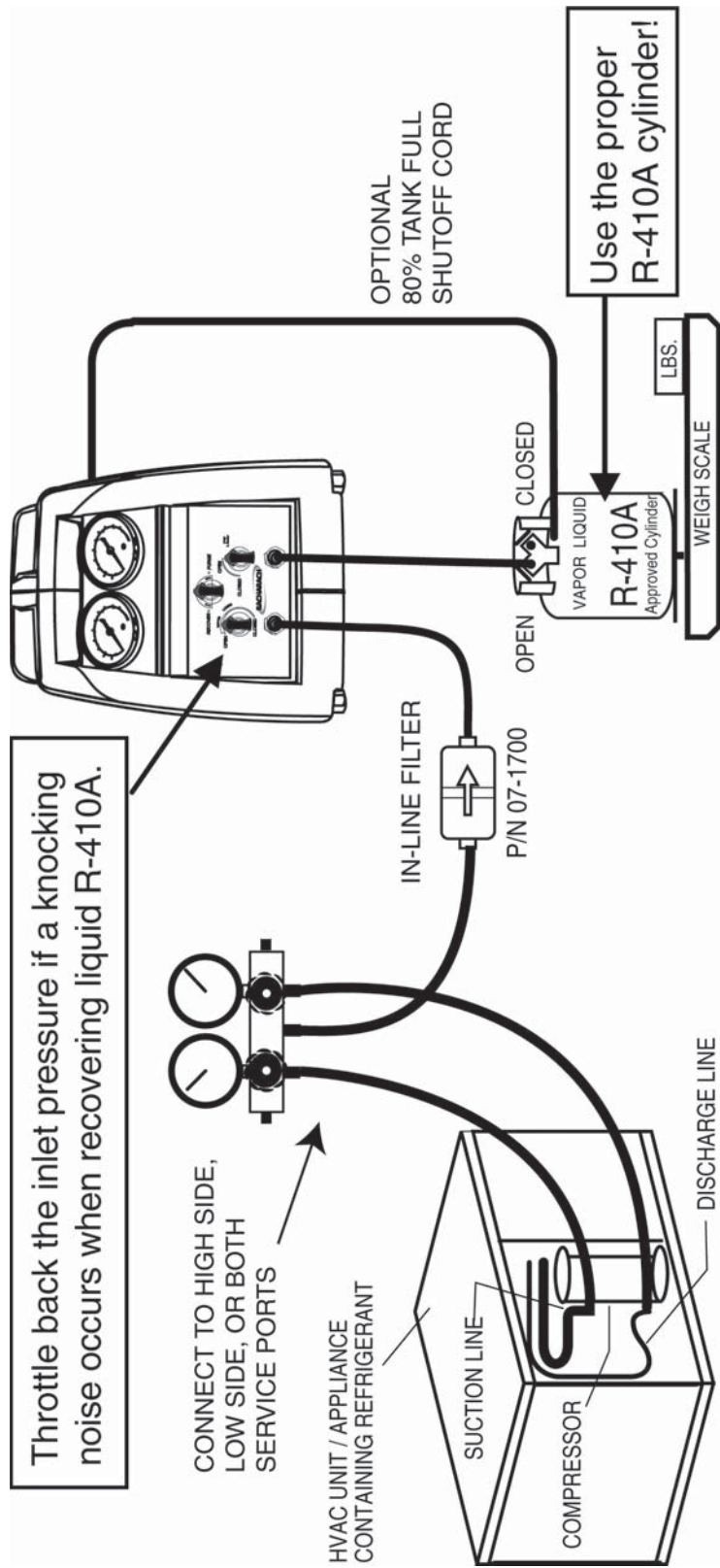

Figure 6. Special Notes for R410-A Recovery

Purging the STINGER

The STINGER is equipped with a pump-down purge valve that allows the technician to pump down or evacuate the STINGER before proceeding to the next recovery operation. This procedure not only eliminates cross contamination, but also conserves refrigerant. Follow the steps below to ensure your pump-down operation is performed correctly.

During the purge operation the entire STINGER is pulled into a vacuum, leaving no more than 0.1 ounce of refrigerant in the unit.

STEPS

1. After recovery operations are complete, and with the unit still **powered ON** and **running**, make the following control valve position changes (refer to illustration below):
 - Turn the inlet valve (*blue knob left side*) **slowly** to the “PURGE” position (pointer DOWN position).
 - Turn the purge valve (*black knob center*) **slowly** to the “PURGE” position (pointer DOWN position).
2. The STINGER will now start purging itself of refrigerant. Allow the unit to run until the inlet gauge indicates that there is an adequate vacuum present in the system.
3. Turn OFF the STINGER and then turn the outlet valve (*red knob right side*) to its “CLOSED” position.
4. Close the **Vapor** and **Liquid** valves on the DOT recovery tank.
5. Remove all hoses.

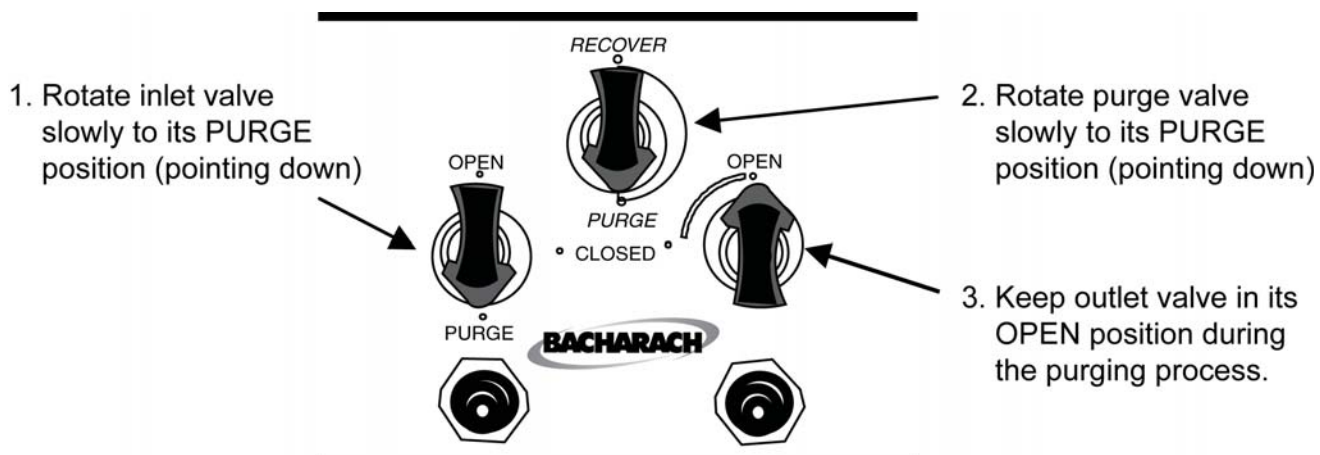

Figure 7. Purging the Stinger

DOT Recovery Cylinder Safety



WARNING! This unit is capable of over-pressurizing a DOT recovery cylinder. Ensure that you are using the proper DOT recovery cylinder for the refrigerant that you are recovering. ***R-410A is capable of pressures exceeding 600 psi.***

Typical DOT recovery cylinders are rated at 350 psi with a pressure relief set at 550 psi. ***These cylinders should not be used with R-410A!*** Only cylinders rated at 400 psi with a pressure relief set at 600 psi should be used to recover R-410A. Failure to use the proper cylinder can be extremely dangerous.

If your STINGER is equipped with the optional 80% tank full shutoff cord, connect this cord to a DOT recovery cylinder's float switch. This cord connection will automatically shut OFF the STINGER when the recovery cylinder reaches 80% of its liquid-full limit. It is recommended that you use this cord for added safety.

If your STINGER is not equipped with an 80% tank full shutoff cord, or if you are using a recovery cylinder that does not have a float switch, ***then you must use a scale to prevent overfilling the cylinder.***

NOTE: If the 80% tank full shutoff cord is present, but not being used, then a shorting cap must be installed on the shutoff cord in order for the STINGER to operate.

Bacharach uses and recommends the Air Conditioning and Refrigeration Institute's (ARI) Guideline K for the safe filling and handling of used refrigerant. This Publication is available from ARI at <http://www.ari.org>.

The following information provides the safe fill weights for used refrigerant based on the size of the container and is in accordance with Guideline K.

WATER CAPACITY	NET REFRIGERANT WEIGHT	GROSS CONTAINER WEIGHT (APPROX.)
30 lbs	24 lbs	38 lbs
50 lbs	40 lbs	59 lbs
95 lbs	76 lbs	118 lbs
145 lbs	98 lbs	153 lbs
238 lbs	190 lbs	274 lbs

Recovery Tips

- Use the shortest hoses possible. Long hoses increase the recovery time. Remove all restrictions in the hoses. Hoses with ball valves on the ends are better than hoses that are self-sealing. Remove Schrader core valves when possible from service ports.
- Always identify the refrigerant you are recovering. This will minimize cross contamination and help you plan for the amount of refrigerant you will be recovering.
- Always pump liquid out of the system first, and then recover the remaining vapors. This will significantly speed up recovery rates.
- With large amounts of refrigerant, use the liquid push-pull recovery method. This method is three times faster than recovering liquid directly. Refer to the liquid push-pull instructions on Page 16.
- When possible, recover from both the high and low side service port on the refrigeration system. This will speed up the recovery rate.
- Use an agency approved in-line filter (P/N 07-1700) to prevent contaminants from entering the STINGER.
- If the STINGER has the optional 80% tank full shutoff cord installed, connect this cord to the recovery cylinder's float switch. If the cylinder does not have a float switch, then be sure to install a shorting cap on the shutoff cord; otherwise, the STINGER will not operate.

NOTE: Although using a manifold gauge set will speed up the recovery process, a manifold gauge set is not required.

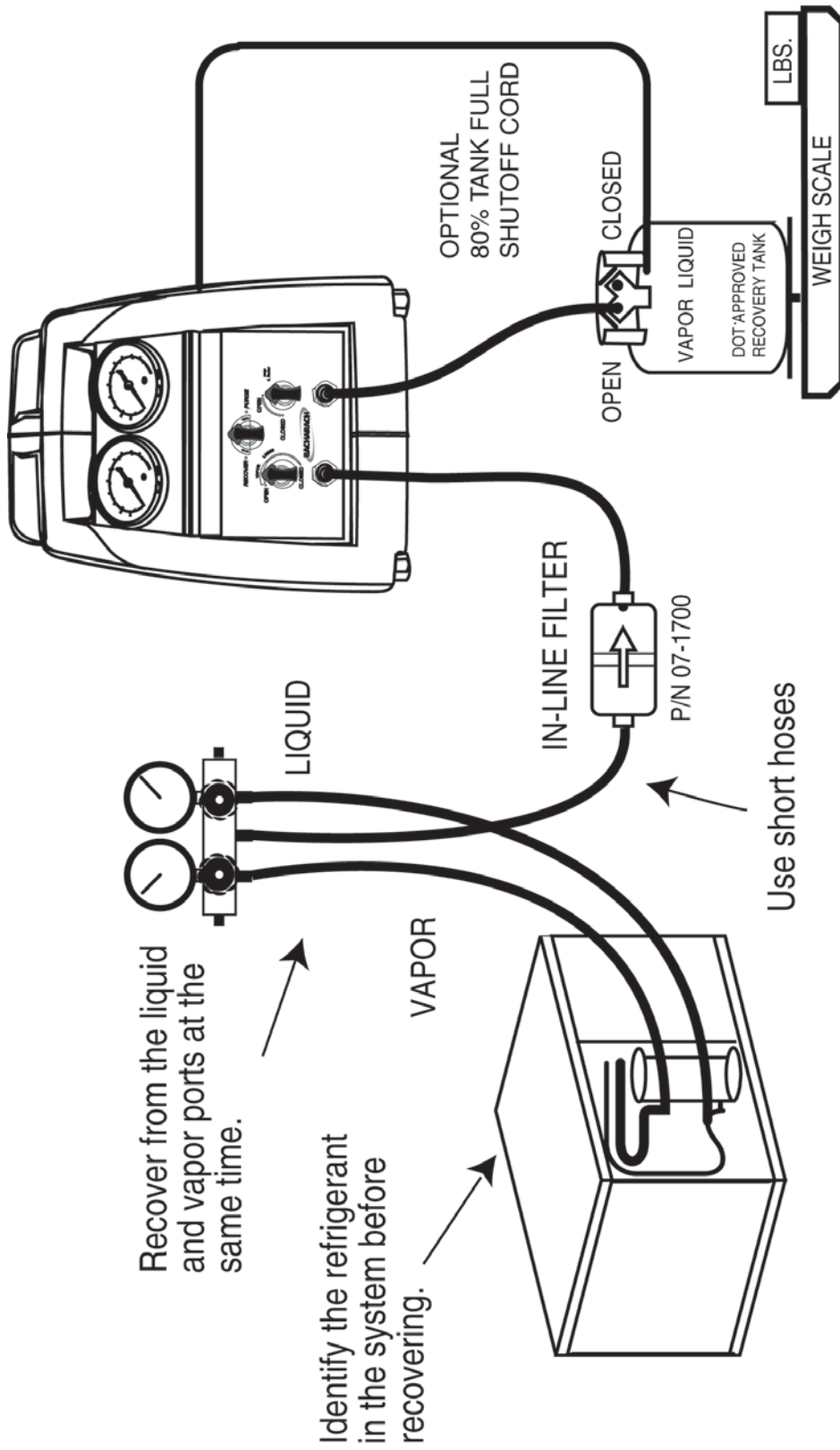

Figure 8. Recovery Tips

Troubleshooting

PROBLEM	CAUSE	ACTION
AC power switch is ON, but fan, compressor, and status LED are all OFF	Power cord not attached No voltage at AC outlet Circuit breaker has opened	Attach power cord. Verify voltage at job site. Identify cause of breaker activation, rectify, and reset.
Status LED glows red –Compressor does not start or stops running	Optional 80% tank full shutoff cord not connected to tank. Tank is full and float switch has opened. Float switch in tank is open. High pressure switch has activated due to discharge pressure exceeding 550 psi. Compressor motor thermal overload has tripped Electronics failure in motor, or on printed circuit board	Connect yellow STI cord to tank. If tank does not have a float switch, short cord and use a scale. Change tanks. To restart, power unit off and on again. Check tank switch with multi-meter. Reduce pressure: Check for restrictions in discharge line and that recovery tank valve is open; rotate function valve to PURGE and back to RECOVER; check that outlet valve is OPEN. To restart, power unit off and on again. Turn OFF unit and allow motor to cool down for at least 15 minutes. Factory service required.
Status LED is OFF – Fan is running, but compressor is OFF	Low pressure switch has activated due to inlet port reaching a vacuum of 13" Hg during recovery process Low pressure switch is still activated even after inlet port has been exposed to atmospheric pressure	System evacuation is complete. Apply 1 – 2 psi pressure to inlet port to reset low pressure switch.

PROBLEM	CAUSE	ACTION
Compressor starts but cuts out within a few minutes; pressure indication on high pressure gauge is high; status LED glows red	Function valve is in PURGE position during recovery and high pressure switch activates Outlet valve is not open and high pressure switch activates Recovery tank valves closed Blocked discharge hose Air in system/tank	Rotate function valve to RECOVER. Rotate outlet valve to OPEN position. Open tank vapor valve. Check and clear blockage. Bleed air from system/tank.
Status LED still glows red after high pressure condition has been cleared	High pressure switch was once activated causing high pressure circuit to latch ON	Turn unit OFF and then back ON.
Compressor starts but cuts out within a few minutes; pressure indication on low pressure gauge is low; status LED is OFF	Inlet valve is in PURGE or CLOSED position during recovery and low pressure switch activates Blocked intake hose	Rotate inlet valve to RECOVER. Check and clear blockage.
AC power switch is ON, but fan, compressor, and status LED are all OFF	Power cord not attached No voltage at AC outlet Circuit breaker has opened	Attach power cord. Verify voltage at job site. Identify cause of breaker activation, rectify and reset.
Status LED still glows red after changing recovery tanks	80% tank full switch has been activated causing tank full circuit to latch ON	Turn unit OFF and then back ON.
AC power switch is ON but cooling fan not running	Defective fan Obstruction in fan blades	Replace fan. Remove obstruction.
Unit overheats	Excessive suction pressure due to high ambient temperature	Reduce inlet pressure below 80 psi by throttling the inlet valve.

PROBLEM	CAUSE	ACTION
Recovery process too slow	<p>Head pressure too high</p> <p>System refrigerant iced up</p> <p>Restriction in hoses or manifold gauge set</p> <p>Compressor seals worn</p>	<p>Reduce tank temperature or change tanks.</p> <p>Throttle gauge manifold valves and discharge valves to reduce pressure differential between LP and HP gauges.</p> <p>Interrupt recovery process and allow ice to dissipate.</p> <p>Check and clear restriction.</p> <p>Rebuild compressor.</p>

Schematic Diagram

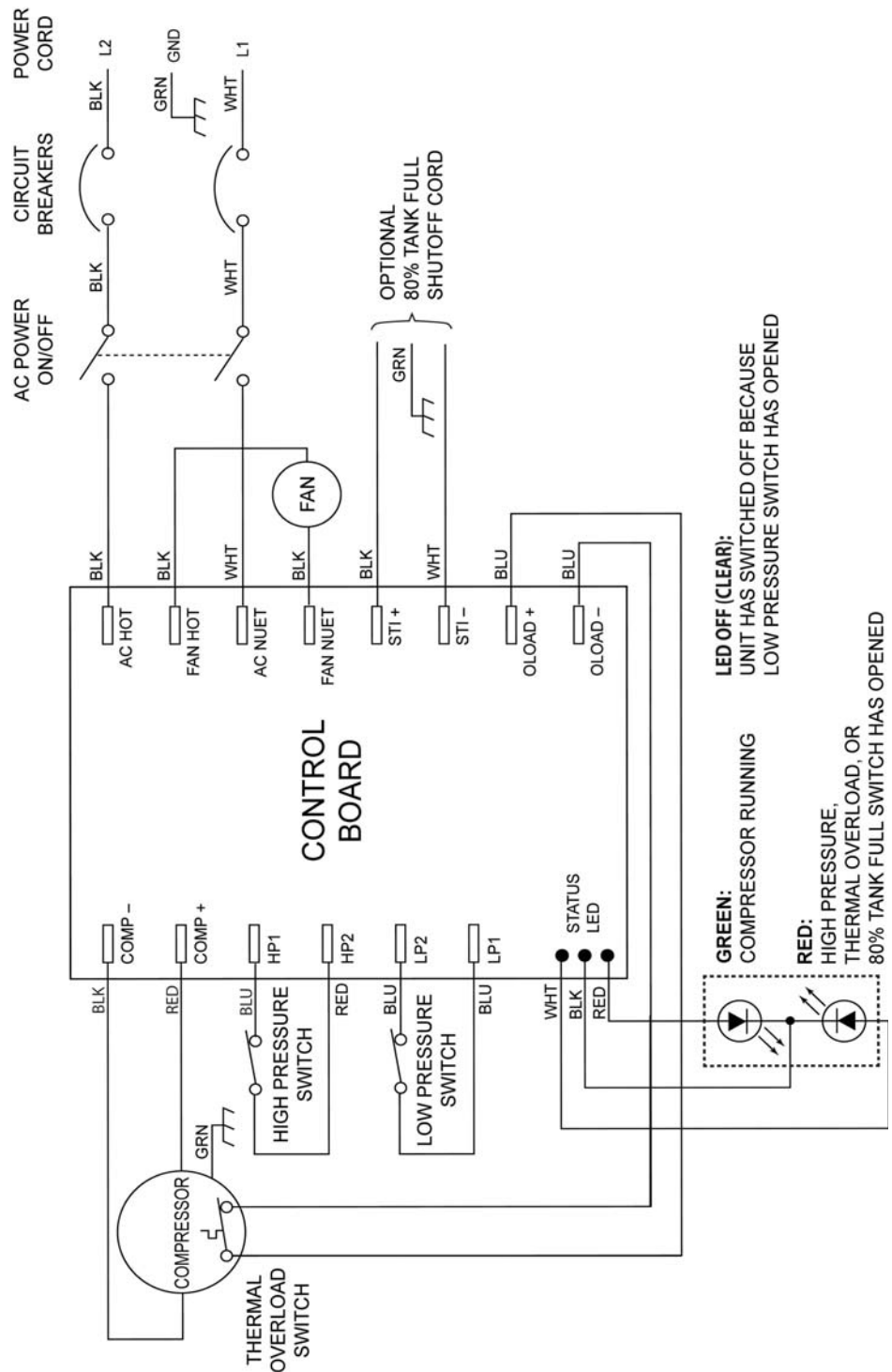

Figure 9. Schematic Diagram

STINGER Parts List

See exploded view of STINGER in Figure 10.

Item No.	Part Number	Description	Qty
1	2045-0620	Compressor (110/120 VAC)	1
1	2045-0720	Compressor (230 VAC)	1
1	2090-2042	Compressor (240 VAC)	1
2	2023-0100	Manifold	1
3	2014-0310	High Pressure Switch, 550 psi	1
4	2013-0090	Fan, 4", 110/120 VAC	1
4	2013-0040	Fan, 4", 230 VAC	1
5	2014-0090	Vacuum Switch	1
7	2063-0150	Gauge, Low Pressure	1
8	2063-0160	Gauge, High Pressure	1
12	2014-0030	Circuit Breaker, 10 amp	2
13	2013-0055	Compressor Fan Blade	1
15	2090-0059	Power Switch	1
16	2043-0120	Plastic Knob, Outlet, Red	1
17	2043-0100	Plastic Knob, Inlet, Blue	1
18	2043-0110	Plastic Knob, Black	1
--	2090-0217	Instruction Manual	1
--	2090-0091	80% Tank Full Shutoff Kit	(Optional)

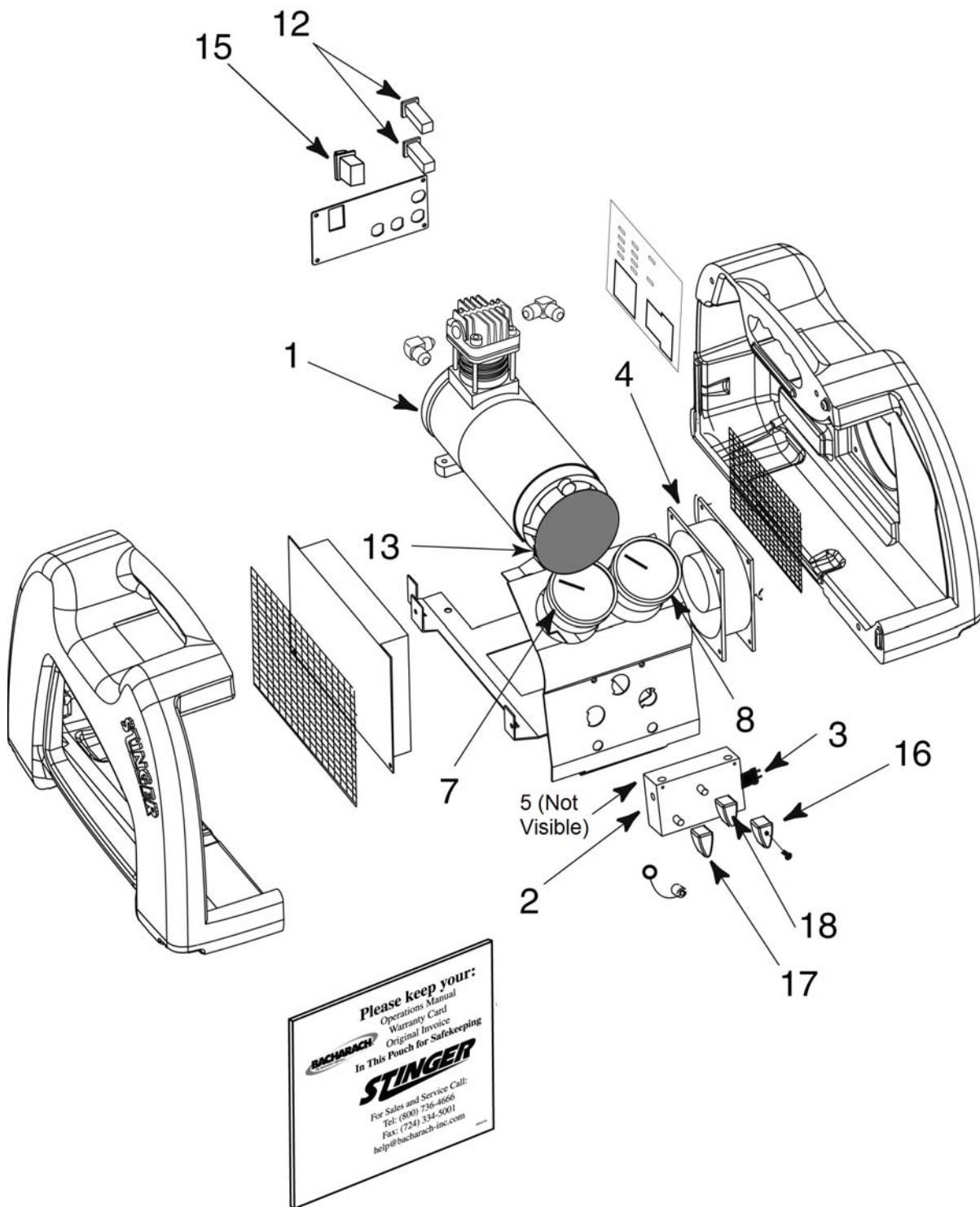

Figure 10. Stinger Exploded View

Compressor Parts List

See exploded view of compressor in Figure 11.

Part No.	Item	Description	Qty
2051-1900	4	Screw, Machine, M5 x 10MM	1
2081-0310	5	Piston Cup Seal Retainer	1
2043-0020	6	Piston Cup Seal	1
2081-0270	7	Piston	1
2081-0400	8	Piston Journal Bearing	1
2081-0260	9	Crank	1
2077-0940	10	Crankcase Cover Gasket	1
2081-0390	*13	Shim, 0.002"	1
2081-0420	*14	Shim, 0.003"	1
2081-0430	*15	Shim, 0.005"	1
2077-0950	16	O-Ring, #026	1
2081-0290	17	Cylinder	1
2090-0039	18	Valve Plate Assembly	1
2081-0280	19	Cylinder Head	1
2051-1910	20	Screw, Cap, M5 x 50MM	4
2090-0040	21	Motor Brushes	2
2090-0042	--	Compressor Rebuild Kit Includes Items 4, 5, 6, 16, 18	1

*Any or all of these shims may be used.

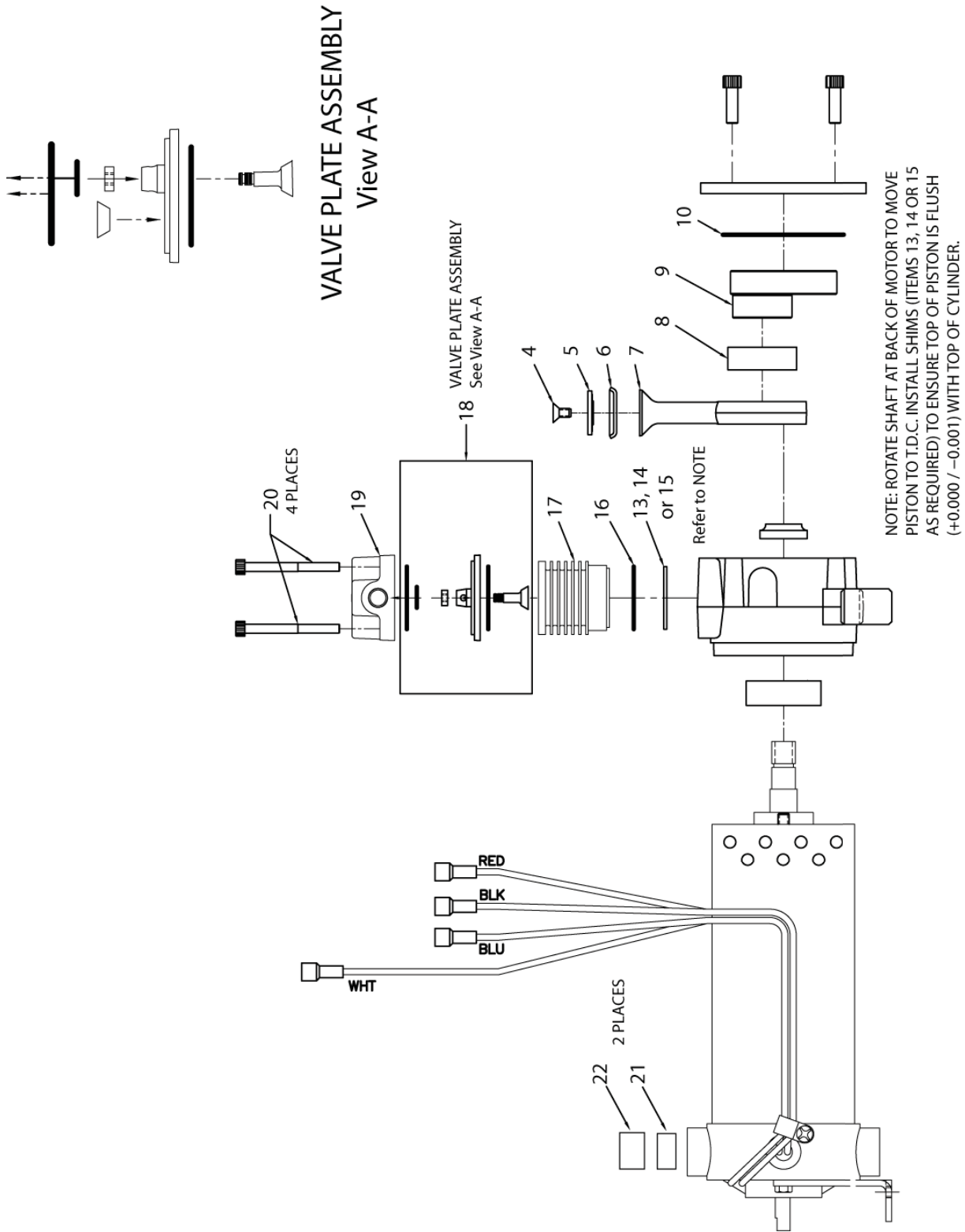

Figure 11. Compressor Exploded View



CE DECLARATION OF CONFORMITY

The manufacturer of the products covered by this declaration:	Bacharach, Inc. 621 Hunt Valley Circle New Kensington, PA 15068
Year conformity is declared:	2009
Product(s):	Refrigerant Recovery Machine
Model(s):	Stinger

The undersigned hereby declares that the above referenced products are in conformity with the provisions of the following standard(s) and is in accordance with the following directive(s).

Standard(s):

EN 61326-1:2006	General EMC Requirements	Electrical equipment for measurement, control, and laboratory use
-----------------	--------------------------	---

Directive(s):

2004/108/EC	EMC Directive
-------------	---------------

Signature: 

Name: Doug Keeports
Title: VP of Product Development
Date: 23 August 2010

The technical documentation file required by this directive is maintained at the corporate headquarters of Bacharach, Inc.



World Headquarters

621 Hunt Valley Circle, New Kensington, Pennsylvania 15068

Phone: 724-334-5000 • Toll Free: 1-800-736-4666 • Fax: 724-334-5001

Website: www.MyBacharach.com • E-mail: help@MyBacharach.com

