

THERMOTORCH 5

3 IN 1 HAND WARMER FLASHLIGHT AND POWER BANK

Model # 94552



Thank you for purchasing the ThermoTorch 5 3-in-1 Hand Warmer, Flashlight and Power Bank! With a traditional tactical flashlight design, it's CNC aluminum housing is water resistant, dust proof and drop tested. It has a built in hand warmer feature that will provide up to 6 hours of scent free heat, a 300 lumen, CREE® 5W LED-3 mode flashlight and is capable of charging your personal electronic devices, with its powerful 5000 mAh rechargeable lithium ion battery. It is a must have for any serious outdoor enthusiast!

WARNING: Read all instructions and warnings thoroughly before using the ThermoTorch 5. Improper use of this product may result in product damage, excess heat, toxic fumes, fire or explosion. Not intended for children.

INCLUDED IN THE BOX ARE:

- 1 - ThermoTorch 5
- 1 - USB Cable
- 1 - Rugged canvas holster with belt loop

PARTS CALLOUT:

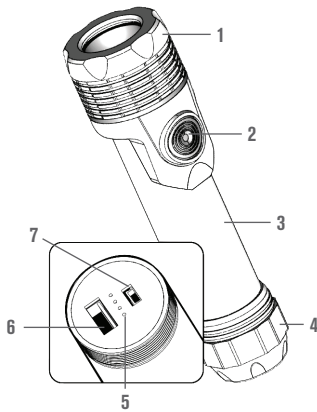

- 1. Flashlight with CREE® 300 lumen LED
- 2. Power Button with Hand warmer LED indicator
- 3. Main Heating surface/handle
- 4. End cap
- 5. Battery indicator LEDs (4)
- 6. USB "OUT" port: (standard 2.0) 5V- 2.1A
- 7. Mini USB "IN" port

1. CHARGING THE INTERNAL LITHIUM ION BATTERY

Your ThermoTorch 5 has an internal, 5000 mAh rechargeable lithium ion battery, which allows for up to 6 hours of continuous use at a constant temperature of up to 45° Celsius (113° Fahrenheit). The ThermoTorch 5 ships with a partial charge, but you should charge it completely before using it for the first time.

STEPS

1. Unscrew the End cap (4) to expose the USB ports (the cap will stay tethered to the main housing via nylon cord).
2. Plug the standard USB plug end of the included USB cable into a USB port on a PC, laptop, car charger or USB 5V 2.1A Max adapter plug.
3. Plug the mini USB end of the included USB cable into the "IN" port (7) on your ThermoTorch 5.
4. Once plugged in, the blue LEDs (5) will start blinking indicating a charge is in progress.
5. Charging is complete when all 4 blue LEDs (5) stop blinking.

2. USING THE FLASHLIGHT

- Press and release the power button (2) to turn on the flashlight.
- The flashlight has 3 modes: Low, Medium and High.
- Each press and release of the power button will toggle through the modes and then power the flashlight off.

3. USING THE HAND WARMER FEATURE

- Press and hold the power button (2) until the button illuminates blue.
- This indicates the Hand warmer is in use and the Main heating surface (3) will begin to heat up. In minutes, it will reach its maximum temperature.
- Press and hold the power button (2) to turn off the hand warmer.

NOTE: To maintain water resistance, the end cap (4) must be secured tight. Bear this in mind when checking battery indicator LEDs (5).

4. CHARGING AN EXTERNAL DEVICE

- Simply plug your device's USB 2.0 plug into the standard USB "OUT" port (6) on the ThermoTorch 5 while the other end of your charging cable is connected to your smartphone, tablet, camera or MP3 player.
- The internal battery will automatically start charging your device.

NOTE: The USB OUT Port is rated at 5v-2.1A out, which is designed to work best with tablets.

- The battery indicator LEDs (5) will display the battery power while you charge (1 LED- 25%, 2 LEDs- 50%, 3 LEDs- 75%, 4 LEDs- 100%)

5. SPECIFICATIONS

BATTERY: Rechargeable lithium ion battery- 5000 mAh

INPUT: Mini USB Connector / 5V 1.8A Max

HAND WARMER CONTINUOUS USE TIME: Up to 6 hours continuous use (based on fully charged battery)

HAND WARMER TEMPERATURE RANGE:

UP TO 45° C (113° F)

IP-65 RATED: Complete dust protection (6) Water resistant (5)

FLASHLIGHT FEATURE: CREE® XLAMP® XP-G2- 5W

3 MODES

1. LOW: 60 lumens
2. MED: 100 lumens
3. HIGH: 300 lumens

C-LINK FEATURE: Compatible with other Celestron Elements power banks for extending heat time and recharging the internal battery

OUTPUT: Standard 2.0 USB port: 5V- 2.1A

(Smart Charge Technology)

AUTO-CHARGE FEATURE: Plug into the standard USB port and ThermoCharge will automatically start charging your electronic device.

LED STATUS INDICATORS:

(4) Blue- Battery indicator LEDs

(1) Blue- Hand warmer indicator (power button)

OPERATING TEMPERATURE RANGE:

0° to 45° Celsius (32° to 113° Fahrenheit)

STORAGE TEMPERATURE RANGE:

68° to 77° Fahrenheit (optimal)

ACCESSORIES: Rugged canvas holster with belt loop

WEIGHT: 12.45 oz. (353 grams)

DIMENSIONS: 6.5 in x 2.0 in x 2.0 in

(165 mm x 52.5 mm x 52.5 mm)

POWER DELIVERY CHART:

Smartphone (2100 mAh): 2 charges

Tablet (8200 mAh): .5 charges

MP3 Player (1100 mAh): 3.5 charges

Sports CAM (1100 mAh): 3.5 charges

WARNINGS:

Read all instructions and warnings prior to using this product. Improper use of this product may result in product damage, excess heat, toxic fumes, fire or explosion, for which damages you ("Purchaser"), and not Smart Team or Celestron (collectively "Manufacturer") are responsible.

- Do not store battery in high temperature environment, including intense sunlight.

- Do not place battery in fire or other excessively hot environments.

- Be cautious of excessive drops, bumps, abrasions or other impacts to this battery. If there is any damage to the battery

such as dents, punctures, tears, deformities or corrosion, due to any cause, discontinue use and contact manufacturer or dispose of it in an appropriate manner at your local battery recycling center.

- Do not disassemble this battery or attempt to repair or modify it in any manner.
- Do not expose this battery to moisture or submerge it in liquid.
- Do not attempt to charge battery using any method, apparatus or connection other than the device's USB connector. For questions or instructions for the various ways to charge the Model #94552 3-in-1 Hand Warmer, Flashlight and Power Bank, refer to this manual.
- Do not attempt to replace any part of this battery.
- This battery is intended for adult use only. If this battery is intended by Purchaser to be used by a minor, purchasing adult agrees to provide detailed instructions and warnings to any minor prior to use. Failure to do so is sole responsibility of Purchaser, who agrees to indemnify Manufacturer for any unintended use/misuse by a minor.
- If you find that your battery is excessively hot, is emitting odor, is deformed, abraded, cut or is experiencing or demonstrating an abnormal phenomenon, immediately stop all battery use and contact Manufacturer.
- For extended storage, first charge your battery for at least one hour.
- It is not recommended to store device for more than 3 months without use as batteries may have a tendency to discharge.
- Never dispose of batteries in the garbage. Disposal of batteries in the garbage is unlawful, in The United States, under state and federal environmental laws and regulations. Always take used batteries to your local battery-recycling center.

DISCLAIMER:

Manufacturer shall not in any way be liable to you or to any third party for any damages you or any third party may suffer as a result of use, intended or unintended, or misuse of this battery. Manufacturer will not be responsible for any damages you or any third party may suffer as a result of misuse of this battery as outlined above. If you are responsible for battery use with an unintended mobile device and damages result from such use, you agree to indemnify Manufacturer for any resulting injuries to any third party or parties.

This device complies with part 15 of the FCC Rules. Operation is subject to the following two conditions:

(1) This device may not cause harmful interference, and (2) this device must accept any interference received, including interference that may cause undesired operation.

NOTE: This equipment has been tested and found to comply with the limits for a Class B digital device, pursuant to part 15 of the FCC Rules. These limits are designed to provide reasonable protection against harmful interference in a residential installation. This equipment generates uses and can radiate radio frequency energy and, if not installed and used in accordance with the instructions, may cause harmful interference to radio communications. However, there is no guarantee that interference will not occur in a particular installation. If this equipment does cause harmful interference to radio or television reception, which can be determined by turning the equipment off and on, the user is encouraged to try to correct the interference by one or more of the following measures:

1. Reorient or relocate the receiving antenna.
2. Increase the separation between the equipment and receiver.
3. Connect the equipment into an outlet on a circuit different from that to which the receiver is connected.
4. Consult the dealer or an experienced technician for help

CAUTION: To comply with the limits of the Class B digital device, pursuant to Part 15 of the FCC Rules, this device is comply with Class B limits. All peripherals must be shielded and grounded. Operation with non-certified peripherals or non-shielded cables may results in interference to radio or reception.

MODIFICATION: Any changes or modifications not expressly approved by the grantee of this device could void the user's authority to operate the device



Torrance, CA 90503
TEL (800) 421-9649 | celestron.com
Copyright 2015 Celestron | All rights reserved.

(Products or instructions may change without notice or obligation.)

Designed and intended for those 14 years of age and older.
V2.0