

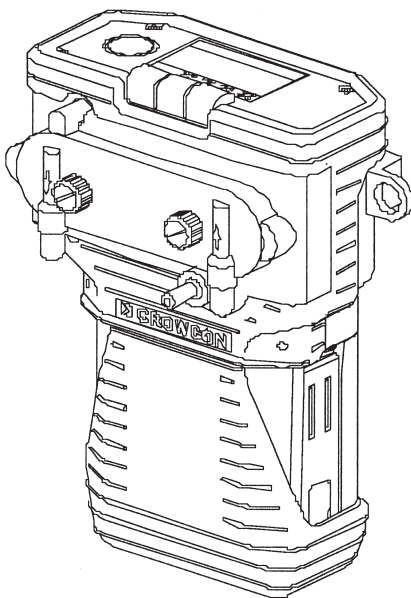

## Custodian CDL

Multichannel Personal Gas Monitor

## Instruction Manual



## Quick Operating Guide

<b>Switch on:</b>	Press button
<b>Normal condition:</b>	Intermittent green LED flash and blip
<b>Alarm condition:</b>	Fast flashing red LEDs and sounder
<b>Alarm reset:</b>	Press button
<b>Activate backlight:</b>	Press button
<b>Switch instrument off:</b>	Press and hold button - instrument will display 5 second countdown then turn off automatically.
<b>Use of Manual Aspirator:</b>	With the aspirator assembly attached a minimum of 10 pumps with the hand bulb are required

## Instruments fitted with internal pump

Switching pump on and off:	Pump is activated and de-activated by fitting or removing the flow adaptor.
----------------------------	---

**NOTE: Do not connect a pressurized gas cylinder with the pump running.**



This product has been tested and found to comply with the European Directive 89/336/EEC

---

## Contents

<b>1. UNPACKING .....</b>	<b>5</b>
<b>2. INTRODUCTION .....</b>	<b>6</b>
<b>3. SPECIFICATION .....</b>	<b>7</b>
<b>4. OPERATION .....</b>	<b>9</b>
4.1 SWITCH-ON SEQUENCE .....	9
4.2 RUN MODE .....	10
4.3 DISPLAY SYMBOL GUIDE .....	11
4.4 DISPLAY OPTIONS .....	12
4.5 DATALOGGING .....	12
<b>5. BATTERY PACK .....</b>	<b>14</b>
5.1 CHANGING THE BATTERY PACK .....	14
5.2 RECHARGING .....	15
<b>6. ALARM TYPES .....</b>	<b>16</b>
<b>7. FIXING ACCESSORIES .....</b>	<b>17</b>
<b>8. USING PUMPED VERSIONS OR ASPIRATORS .....</b>	<b>18</b>
8.1 DIFFUSION INSTRUMENTS .....	18
8.2 PUMPED INSTRUMENTS .....	19
8.3 CALIBRATION METHOD .....	20
<b>9. ROUTINE CHECKING .....</b>	<b>21</b>
9.1 GENERAL .....	21
9.2 SENSOR FILTER .....	21
9.3 ZERO AND CALIBRATION .....	21
9.4 MONTHLY GAS CHECK .....	21
<b>10. PC INTERFACE AND SOFTWARE .....</b>	<b>23</b>

<b>11. SENSOR REPLACEMENT .....</b>	<b>24</b>
<b>12. SENSOR LIMITATIONS .....</b>	<b>26</b>
<b>13. TROUBLESHOOTING GUIDE .....</b>	<b>27</b>
13.1 STATUS MESSAGES .....	27
13.1 SERVICE: .....	28
<b>14. ACCESSORIES AND SPARE PARTS .....</b>	<b>29</b>
14.1 ACCESSORY LIST .....	29
14.2 SPARE PARTS LIST .....	30

# 1. Unpacking

Each Custodian CDL is supplied in one or two boxes, depending on which options and accessories have been ordered. Each box has a label detailing the contents of the box. Should the content not agree with the label, please contact Crowcon immediately and have ready the serial number of the instrument in question. The serial number can be found at the bottom of the label on the rear of the main instrument. The battery pack has its own code number found on the main battery pack label.

***Note: When checking the contents of boxes, remove all items from the foam packing and remove the foam. This will expose a false bottom which can be opened by inserting a finger in the hole provided and hinging up. In most boxes, further contents will be found in this lower compartment.***

***The rechargeable batteries can occasionally discharge during transit. See Switch-on Sequence (p9) for details of the battery level indicator.***

## 2. Introduction

The Crowcon Custodian CDL is a portable gas detector, which can monitor up to four gases simultaneously. It is designed to be carried or worn by individuals working in hazardous environments such as confined spaces, and will give a loud audible and bright visual alarm warning when preset concentrations of gas are detected. It also internally logs data, which can be accessed by connecting the unit to a PC.

Detailed mechanical design features have resulted in an easy to service instrument with sealing to IP66.

The user interface has been designed for simple 'one button operation'. The shape of the instrument has been designed to fit comfortably against the body and pose the least restriction on movement. It can fit in a pocket, on a belt or a chest harness.

The detachable battery pack can be replaced in a hazardous zone for round the clock operation. The rechargeable packs utilize environmentally friendly nickel metal hydride batteries with a life of up to 1000 charge/discharge cycles. These will power an instrument with one flammable sensor and three electrochemical sensors for up to 14<sup>1</sup>/<sub>2</sub> hours.

The sensor module can be detached and replaced for easy field maintenance.

### 3. Specification

Weight	500g (1.1lbs)
Dimensions	155mm x 102mm x 52mm (6.1" x 4" x 2")
Typical measuring ranges	0-100% LEL flammable gas, 0-25% volume oxygen, 0-50ppm hydrogen sulphide, 0-500ppm carbon monoxide.
Typical alarm levels (3 per channel plus TWA alarms for toxic channels)	20%LEL and 40%LEL, 17%, 19% and 23% oxygen, 5ppm and 10ppm hydrogen sulphide, 30ppm and 100ppm carbon monoxide instantaneous alarms and/or TWA alarms (STEL and LTEL)
Response times ( $T_{90}$ )	Methane 20 seconds, oxygen 10 seconds, typical toxic gas 20 seconds.
Visual alarm indicators	Ultra bright flashing red LED pair in ALARM mode. Slow flashing green LED in NORMAL mode.
Audible alarms	Programmable from six different tones, 85dBA at 1 metre. Intermittent sound for discharged battery. Confidence blip (selectable).
Display	Custom 7 segment high contrast LCD. 8mm character height for gas readings. Symbols for low battery, TWA alarm, blocked pump. Bright backlight.
Operating temperature range	-20°C to 50°C (-14°F to 122°F)
Humidity	0-95% RH, non-condensing for the instrument typically 10-90% RH for toxic sensors.

Expected sensor life	Pellistor 5 years, toxic gas 3 years, oxygen 1 year standard, 2 year optional (see page 26).
Detachable battery pack	1.1Ah nickel metal hydride rechargeable: typical life 14.5 hours diffusion mode, 12 hours pumped.
Aspirator/electric pump	Manual bulb type with 2m of hose, non-absorbent, hydrocarbon resistant. Internal electric pump option with auto on/off.
Safety Certificate Nos.	Instrument: Ex95C2349 Flam sensor block: Ex95Y1350 Battery pack: Ex95C2348X <sup>t</sup>
Approval code (Europe)	Instrument: E Ex ia IIC T4 (T <sub>amb</sub> =55°C)
	Flam sensor block: E Ex d IIC T4
	Battery pack: E Ex ia IIC T3 (T <sub>amb</sub> = 50°C)
(USA & Canada)	Class 1, Division 1, Groups A, B, C and D.
Standards: Europe	EN50014, EN50020, EN50018
USA & Canada	UL 913, CSA 22.2
RF Immunity	Tested to IEC801-3 and meets EN50082-1
RF Radiation	Tested to EN55022 Class B and meets EN50081-1
Battery charging	Dual rate charger for instrument or detached battery pack. Fast charge in 6 hours, trickle charge will not damage batteries. Input 100-250 VAC or 12-30 VDC.

<sup>t</sup> The suffix X indicates a special condition whereby when disconnected, the ingress protection (IP) rating of the battery pack is lower than when it is attached to the instrument.



## 4. Operation

### 4.1 Switch-on Sequence

**NOTE:** *Before switching the detector on ensure you are in clean air.*

To switch on the instrument, press the button.

The instrument tests all LCD segments, red alarm LEDs and sounder for 5 seconds, you can press the button to silence the sounder at this point. It then displays the software version and battery level before entering the **Warm-up** mode. During **Warm-up** the display counts down from 40 seconds. When the count reaches 0 the detector will enter the **Run** mode.

During **Warm-up** the display normally flashes 'ZEr?' alternately with the timed countdown, asking if the unit should autozero when it enters the Run mode. To confirm autozero is required press the button at any stage during this warm up. An indicator bar will then be displayed above the zero label showing that autozero has been confirmed. ***If there is doubt as to whether you are in fresh air during start up, do not confirm that Autozero is required.***

If the indicator bar above zero is present as soon as the warm starts this indicates the instrument has been configured optionally for fully automatic autozero, and 'ZEr' will not show during warm up.

**NOTE:** *For rechargeable battery packs, a reading of below 4.5V indicates that the batteries require charging. For the first 4-5 recharge/discharge cycles, rechargeable batteries cannot hold a full charge. Therefore, the operation time is around 7<sup>1</sup>/<sub>2</sub> hours for the first few charges.*

Once in the **Run** mode, the green 'confidence' LED will flash and the speaker bleeps every few seconds to reassure users that the instrument is working and the environment is safe. It is now ready to be used. Note the audible bleep may be turned off using the Portables PC software program (see the handbook supplied with Portables PC for further details).

The instrument may display a calibration or service message after the start up routine. Refer to Section 13 of this manual for the details of these messages and correct response to them.

To switch the unit off press and hold the button. The unit will count down 5 seconds, then display 'OFF' and turn itself off

## 4.2 Run Mode

The instrument displays each gas reading in turn for several seconds, cycling back to the first. The channel displayed is indicated by a bar on the LCD under the gas name on the label.

The display may be blanked by a selection in the Portables PC configuration (see the handbook supplied with Portables PC for further details).

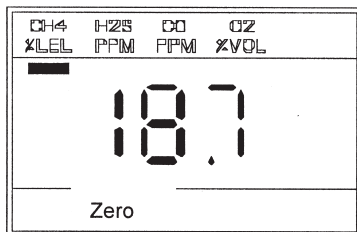

**Figure 1** - Typical **Run** display

The display panel shown in Figure 1 is for an instrument with 4 sensors fitted. The sensor 1 reading is displayed first, indicated by the upper cursor, showing 18.7% LEL CH<sub>4</sub> (methane) present. After

a few seconds the cursor moves to the next position, and H<sub>2</sub>S (hydrogen sulfide) ppm (parts per million) is displayed. A few seconds later it switches to sensor 3 which reads ppm CO (carbon monoxide) then to sensor 4, which displays % by volume oxygen. After completing this cycle, it returns to sensor 1 and repeats.

## 4.3 Display Symbol Guide



### **Battery Low**

When this symbol is flashing (accompanied by faster confidence bleeps) this indicates that there is less than 20 minutes battery life remaining and the instrument requires recharging.



### **Internal Pump**

This symbol indicates that the built-in pump is running. When this symbol flashes (accompanied by a ticking noise) this indicates that the built-in pump or airway is blocked. Check that the flow adaptor and sample lines are free from water or dirt. Also check the sensor filter behind the baffle plate (Figure 6 page 24).

Blockage can occur if a sampling pipe is lowered into a flooded cavity, as the pipe may then suck up water. It can also be triggered if the air intake is blocked with a finger, clothing etc.

Once blocked, the pump will not be restarted unless the flow adaptor is removed and re-attached, or the instrument is switched off and on again or the button is pressed.



### **TWA alarm**

Sometimes appears during alarms (see section 6).

## 4.4 Display Options

Additional displays can be accessed by a double click of the button. Successive double clicks step the display mode from the Normal display to Peak display, then TWA display then back to Normal display.



### Peak Display

In Peak display the instrument shows the highest values seen for flammable and toxic gases, and the lowest value seen for oxygen since turn on. This is useful for vertical entry checks where the whole instrument can be lowered down the shaft rather than just a sampling tube. Prior to carrying out such a test the Peaks should be cleared by switching the unit off then on again. The instrument should be reading fresh air conditions prior to a test. Whilst in Peak mode the display can be stepped round each gas reading in turn by successive presses of the button.



### TWA Display

In TWA display the 8 hour Time Weighted Average for the toxic channels is shown. The display can be toggled between the two toxic channels by sequential presses of the button.

The display will automatically revert to Normal after two minutes, or can be reset to Normal by holding the button down for 1 second.

## 4.5 Datalogging

Custodian CDL logs data at a preset frequency (normally on a 1-minute basis), and stores the data points in memory. Data is

accessed by use of the PC interface and the Portables PC software. The data logging interval can be adjusted using the PC software.

The capacity of data storage is variable due to the use of compression, but at a logging rate of 1 minute the data file can hold between 22 and 66 hours of data.

## 5. Battery pack

### 5.1 Changing the battery pack

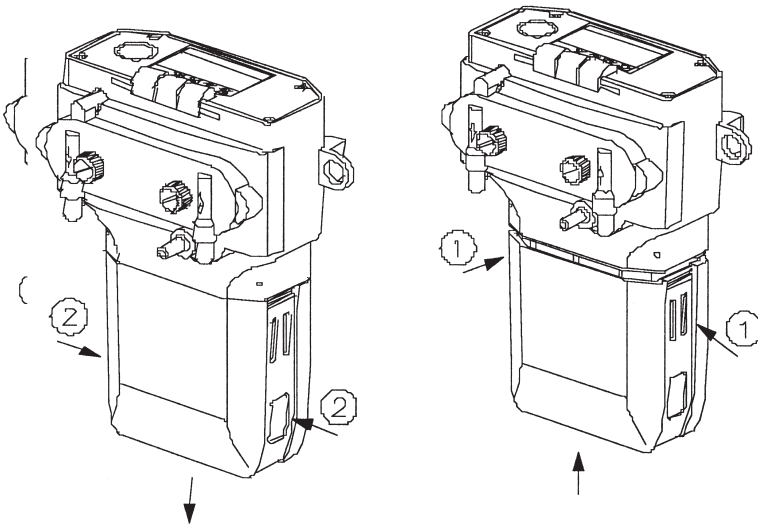

Figure 2 - Changing the battery pack

Note: Switch off before changing the battery pack.

1. To remove the battery pack, press the clips at position 2 and pull the pack from the main body.
2. To re-attach the battery pack, push the pack onto the body and push the clips upward at position 1 until a click is heard from each side.

## 5.2 Recharging

***NOTE: Do not use the charger in a hazardous area!***

Switch the charger on and place the instrument in the charger with the charging contacts towards the rear.

The charger red LED will light while the instrument is undergoing fast charge. Full recharge from flat takes about 6 hours, during which it is normal for the batteries to become warm. After fast charging, the red LED goes out and the green LED comes back on; the batteries are now charged and receiving a trickle current. The instrument can be used immediately or left on charge indefinitely.

Battery packs can be recharged on their own without being connected to the main instrument.

Nickel metal hydride battery packs will self-drain in approximately 1 month. Instruments should therefore be regularly recharged even when not in use.

***NOTE: The battery pack makes contact with the charger via the three small silver contacts on the base of the battery pack. As these are diode protected, no harm will come from these contacts being immersed in water, or otherwise shorted, during use.***

## 6. Alarm types

For each gas channel, there are three instantaneous alarms; level 1, 2 and 3. For toxic gas channels, there are also two time weighted average (TWA) alarms, which operate at short term (15 minute) and long term (8 hour) exposure limits.

Alarm thresholds are set via the computer interface (see the handbook supplied with Portables PC for further details) and the following parameters may be set for instantaneous alarms:

- Normally triggered on a rising level, alarms may be set to trigger on a falling level as with oxygen deficiency alarms.
- Alarms may be latching, requiring manual reset, or self clearing when the hazard has passed.
- Normal alarms cannot be cleared whilst the gas hazard persists. It is possible to set them so they may be silenced (the red LED's will continue to flash). This allows the user to set a 'pre-alarm' warning at a low gas level and a non-silenceable alarm at a higher level.
- Unused alarms may be deactivated.

If any alarm event is triggered, the red LED's will flash and the sounder will emit a loud tone. This tone is selected from a menu available to the Portables PC user (see the handbook supplied with Portables PC for further details).

The gas channel which has detected an alarm condition will be indicated by a flashing LCD bar below the gas name. The gas value of a channel in alarm will flash whilst it is being displayed. If the TWA (Time Weighted Average) symbol appears on the display, this indicates that the total cumulative exposure to a toxic gas has been reached for an 8-hour shift or a 15-minute 'window'. Health & Safety regulations require that workers should leave the hazardous area once they have exceeded this dose. A TWA alarm cannot be manually reset.

The button may be used to silence or clear certain instantaneous alarms as the configuration permits.



## 7. Fixing Accessories

Two fixing accessories are supplied as standard.

1. The transparent belt bracket may be fitted to the rear of the instrument for use with a normal trouser belt.
2. Two small brackets may be fitted to the back of the instrument allowing the use of a shoulder strap

A chest harness is optionally available.

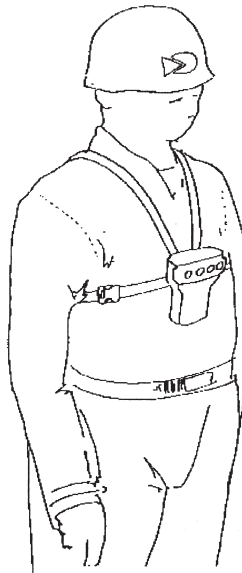

Figure 3 **Chest harness**

## 8. Using pumped versions or Aspirators

For calibration of non-pumped (diffusion) instruments the optional aspirator is required.

### 8.1 Diffusion Instruments

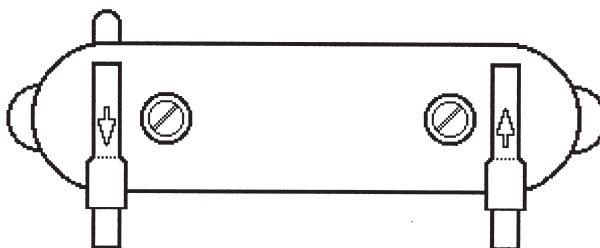

Figure 4 **Aspirator flow adaptor**

The aspirator flow adaptor must be firmly fixed over the grille using the finger screws. The Flow Adaptor has an inlet and outlet nozzle marked by air flow direction arrows. The outlet must be connected to a hand aspirator bulb. A consistent style must be adopted when using hand aspirators - Crowcon recommend squeezing once per second to achieve a flow rate of approximately 0.5 - 1 litre/min. At least 10 pumps per sample are recommended. The oxygen reading will initially dip then return to the original value due to the pressure pulse when sampling begins.

This adaptor may also be used on pumped instruments in which case the internal pump will not run.

## 8.2 Pumped Instruments

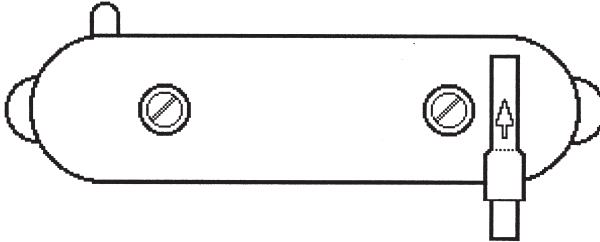

Figure 5 **Pump flow adaptor**

The internal pump switches on automatically when the Pump Flow Adaptor is fitted over the grille. Ensure that the finger screws are firmly fixed. Air is drawn in through the nozzle on the adaptor and exhausted through the small nozzle below the sensor grille. In this configuration, the instrument continuously samples air in its immediate vicinity. A sample tube of up to 20 metres may be connected to the inlet nozzle for remote sampling. On initial sampling there is a small temporary dip in oxygen reading.

Should the flow become restricted or the pump blocked due to ingress of particles or water, the pump will automatically shut down and the PUMP symbol will flash, accompanied by a rapid sequence of warning beeps. To restart, remove the blockage, press the main button or remove and replace the flow adaptor or switch the instrument off and back on.

**NOTE:**

- 1. If the blockage remains, the pump will not restart.**
- 2. The instrument senses the presence of the flow adaptor using a magnet molded into the adaptor. Keep the flow adaptor away from cassette tapes, floppy disks etc.**

## 8.3 Calibration Method

Pass calibration gas through the flow adaptor from a regulated cylinder. Use a flow meter and needle valve set after the regulator to set a flow rate of 0.5 - 1 litre/min. Pumped units should be fed gas from an unpressurized gas bag, alternatively, a standard flow adaptor may be used in which case the pump will not run.

***NOTE: When the calibration gas may represent a toxic risk, it is advisable to connect the outlet to an exhaust bag or fume extractor.***

Typically, calibration gas must be applied for 30 seconds or more before the reading stabilizes to its final level. This reading may then be adjusted to the desired level using the computer interface and PC software, Portables PC.

An automatic calibrator is available to streamline batch calibration.

***NOTE: When calibrating with reactive gases such as H<sub>2</sub>S, care should be taken to ensure that suitable materials are used for piping, valves, etc. Examples of suitable pipe materials are given in the table below.***

Pipe Material	Compatible Gases
HDPE/Nylon	Non-reactive gases (e.g. CH <sub>4</sub> , CO)
PTFE/PVDF	Highly absorbed gases (e.g. H <sub>2</sub> S, CL <sub>2</sub> , SO <sub>2</sub> )
Stainless steel (316)	Non-reactive gases (special)

Ensure sensor apertures are free from dirt and check condition of filter (section 9.2) before calibrating.

## **9. Routine checking**

Custodian is designed to operate almost maintenance free under most conditions. However, some small items of routine maintenance are recommended.

### **9.1 General**

If used in dirty or hostile conditions, a regular wipe over with a damp cloth will help in viewing the display and maintaining easy operation of the pushbutton. This is also recommended for the three small silver contacts on the base of the instrument to maintain good contact for battery charging.

### **9.2 Sensor filter**

This is manufactured from a water repelling material to protect the sensors from immersion. If it becomes wet or dirty it may impede diffusion of gas into the sensors, thereby degrading their performance. The filter is simply cleaned by removing any flow adaptor that may be fitted, removing the sensor baffle plate (see Figure 6 page 24), and washing in warm soapy water. Dry carefully, making sure the material does not rip or break, and replace.

### **9.3 Zero and calibration**

Because all gas sensors change their performance characteristics over time, we recommend the detector is calibrated every 6 months (see section 8.3).

### **9.4 Monthly gas check**

Due to the safety nature of gas detection instruments, it is recommended that sensors are regularly gas checked. Instruments

may be adversely affected by certain environments (section 12). A monthly check with a known gas mixture will ensure the dependability of the equipment.

If during the course of a routine calibration the instrument display show 'SEr' (Service) this would indicate that the sensor has failed calibration and will need replacing.

## 10. PC Interface and Software

Custodian CDL can be connected to a PC to interface to the Crowcon Portables PC software. This provides a user with access to the configuration file allowing changes to the set up, such as to alarm levels and mode of operation. It also provides the facility to upload the data file, which can then be viewed on screen graphically, and exported to a spreadsheet program allowing graphical or tabular printouts to be generated.

To connect the Custodian CDL to a PC remove the battery pack and replace with a Comms Pod and its power supply. Attach the 9-pin D connector from the Comms pod to the Serial Port of a PC and if not already done install the Portables PC software. Switch on the Custodian CDL.

The operation of the Portables PC software is separately described in the manual supplied with the software.

# 11. Sensor Replacement

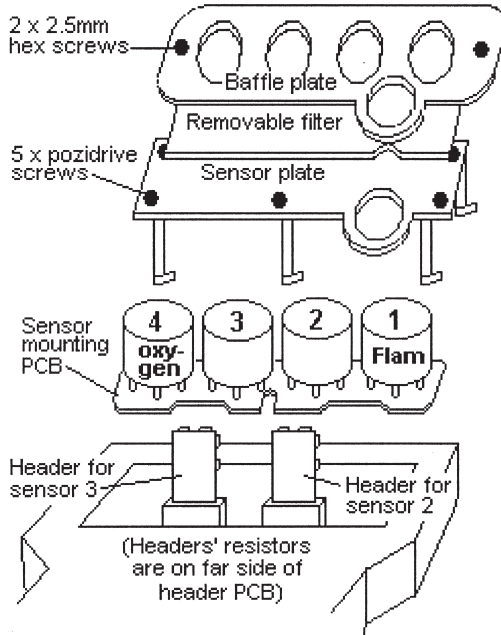

Figure 6 **Sensor removal and replacement**

Remove the flow adaptor if fitted. Remove the grille, which is secured by two Allen, headed screws (an Allen key is provided with each instrument, and is located in the base of the main instrument. Access is gained by removing the battery pack). The removable filter may come away with this component.

Remove the five screws securing the sensor plate assembly and withdraw it from the instrument.

Rotate the quick release fixings, which retain the sensor mounting PCB, and detach it from the sensor plate.



Individual plug-in sensors may now be replaced as required.

When reassembling, ensure that all gaskets and filters are in good condition and correctly fitted.

## 12. Sensor Limitations

Custodian CDL uses a catalytic flammable gas sensor, which measures the flammability of the gas. For this reason, readings displayed on the unit will be unreliable over concentrations of approximately 120% LEL. Oxygen is necessary for catalytic sensors to operate. It is advisable always to check for oxygen concentration in addition to combustible gas concentration prior to entering a confined space. Depleted oxygen levels below 10% will reduce a flammable gas reading.

The performance of catalytic sensor may be permanently degraded if exposed to silicones, sulfur containing gases (such as  $H_2S$ ), lead or chlorine compounds (including chlorinated hydrocarbons).

Use of the unit in ambient temperatures above  $50^{\circ}C$  may cause unstable readings due to inefficient temperature compensation at elevated temperatures. Water saturated air conditions may prevent diffusion of the gas through the sinter on the sensor housing due to build up of moisture.

Custodian uses electrochemical sensors, which include a PTFE membrane. This membrane is unsuitable for use in temperatures above  $55^{\circ}C$ , or in saturated air conditions where condensed water build up on the surface will prevent diffusion of the gas into the sensing chamber. Electrochemical sensors are not wholly specific to their target gas and the presence of other gases may cause the sensor to respond. Full details of cross sensitivities are available from the Crowcon sales department. Use of high power radio transmitters in close proximity to the instrument may exceed RFI immunity levels and cause erroneous indications. If such problems are experienced, remove the antennae to a reasonable separation from the instrument (e.g. 30cm).

## 13. Troubleshooting guide

<i>Symptom</i>	<i>Diagnosis</i>	<i>Remedy / check</i>
Does not switch on	Battery flat	Recharge or replace battery
No confidence bleep	Function disabled	Alter configuration using Portables PC
Reading when no gas present	Zero drifted	Zero instrument in clean air by restarting and confirming autozero
Unstable / inaccurate reading	Sensor failure	Recalibrate using Portables PC or replace sensor
Does not talk with PC	CommsPod unpowered	Connect power

### 13.1 Status Messages:

The instrument may display the following status information after start up:

#### **‘CAL’ flashing alternately with a two-digit code.**

This shows the number of days valid calibration remaining, and will be displayed after start up once the unit is within 30 days or less of its due calibration. The message is cleared by pressing the button allowing the unit to be used normally.

This provides plenty of advance warning of the requirement for calibration to simplify the scheduling of this.

### **‘CAL’ displayed continuously.**

This shows the instrument has passed its due calibration date and needs re-calibrating. The message can be cleared by pressing the button, if the configuration allows this, and the instrument thus used, but it should be sent for re-calibration as soon as possible. The configuration can be set in Portables PC software to not allow clearance of this status message.

### **‘SEr’**

This shows that the instrument has an operating problem requiring it to be sent for a service. This message cannot be cleared and the instrument cannot be used until the problem has been diagnosed and corrected.

## **13.2 Service:**

Servicing is available from the supplier of your Custodian CDL. Portable Gas Detection Instruments should as a minimum be calibrated every six months, and are supplied with six months of valid calibration. Depending on the nature of their use and the extent of potential gas hazards users may need to operate a more frequent checking of the gas response, or more frequent calibration.

## 14. Accessories and Spare Parts

Accessories and spares are available from the supplier of your Custodian CDL.

### 14.1 Accessory List

DC0101	Rechargeable battery pack, complete with batteries
DC0107	Aspirator complete (pumped) with flow adapter & tubing
DC0108	Aspirator complete (non-pumped) with flow adapter, tubing, bulb & pouch.
C01097	Aspirator probe
C03141	6 metre drop line
DC0103	Battery charger with no power supply, for 12V DC input
DC0115	Battery charger with 230V power supply for UK only
DC0116	Battery charger with 230V power supply for Europe only
DC0117	Battery charger with 110V power supply for US only
DC0118	Battery charger with 230V power supply – no plug
DC0119	Battery charger with 110V power supply – no plug
C01296	Charging lead for vehicle lighter socket
DC0105	Comms pod. Requires 12 volt power supply
DC0120	Comms pod with 230V power supply for UK only.
DC0121	Comms pod with 230V power supply for Europe only
DC0122	Comms pod with 110V power supply for US only
DC0123	Comms pod with 230V power supply without plug
DC0124	Comms pod with 110V power supply without plug
DC0114	Chest harness

## 14.2 Spare Parts List

DM0442	Conductive rubber boot
DM0414	Pocket clip
DM0413	Belt clip
DM0214	Battery pack clip
DM0440	Battery pack gasket
DM0441	Battery pack gasket mounted on main body
M05728	Keypad scratch proof cover
C01323	Shoulder strap
DM0430	Shoulder strap bracket
M04032	Aspirator hose by the metre
M04001	Aspirator bulb
DC0106	Aspirator pouch
DC0132	Aspirator flow adapter, fittings, bulb and tubing
DC0107	Pumped flow adapter, fittings and tubing
DM0410	Outer grill
DM0411	Inner grill
DC0111	Set of gaskets (sets of 5, excluding sensor filter assembly)
DC0110	Sensor filter assembly
DM0409	Main body moulding
DM0412	Top cover moulding
DE0110	Sensor flammable 0-100% LEL methane
E01775	Sensor HS 0-50ppm hydrogen sulphide
DE0111	Sensor OX 0-25% oxygen, 1 year sensor
E01764	Sensor OX 0-25% oxygen, 2 year sensor
E01774	Sensor CO 0-500ppm carbon monoxide
DM0420	Dummy tox/ox sensor for blank channels
DM0207	Dummy flammable sensor for blank channels
C01009	Allen key 2.5mm
DM0709	Instruction card

---

M07233	Instruction manual English
C01830	Portables PC software
C01296	Charging lead for vehicle lighter socket to charger
E01535	Power supply for charger/comms pod 230V for UK only
E01536	Power supply for charger/comms pod 230V for Europe only
E01537	Power supply for charger/comms pod 110V for US only
E01552	Power supply for charger/comms pod 230V no plug
E01553	Power supply for charger/comms pod 110V no plug
M03650	Outer grill fixing hex headed screw, 2 required
M03651	Battery pack lid hex headed screw, 2 required
M03649	No. 2 self-tapping screw, 20 required

