



GfG Instrumentation
Worldwide Supplier of Gas Detection Solutions

Transmitter
CS 21
Operation Manual



Content

	Page
For your Safety	3
General Description	3
Detection Principle	4
Operational Notes	4
Design	4
Mounting Position of CS21	5
Mounting	6
Installation of Electrical Connections	6
Putting in Operation	7
Check of Electrical Zero point	7
Check of Sensitivity	7
Service	9
Maintenance and Inspection	9
Trouble Shooting	9
Spare Parts	9
Accessories	9
Connection Diagram CS21 / Built-in Sensor	10
Connection Diagram CS21 / External Sensor	11
Technical Data	12

For your Safety

As any piece of complex equipment, the GfG transmitter CS21 will do the job designed to do, only, if it is used and serviced in accordance with the manufacturer's instructions. Please protect yourself and your employees by following them. All individuals who have or will have the responsibility for using and servicing this product must carefully read this manual. The warranties made by GfG with respect to the product are voided, if the adjustment of functions or parameters is changed without permission from GfG. They are also voided, if the product is not used and serviced in accordance with the instructions in this manual. Failures or false alarms caused by interfering gases or electrical signals are not part of the warranty obligation. The above does not alter statements regarding GfG's warranties and conditions of sale and delivery.

General Description

A fixed gas monitoring system consists of a transmitter and a control module, which are connected by means of a transmitter cable. The transmitter converts the gas concentration into an electrical signal, which is sent to the control module for evaluation.

Fixed Gas Monitoring System

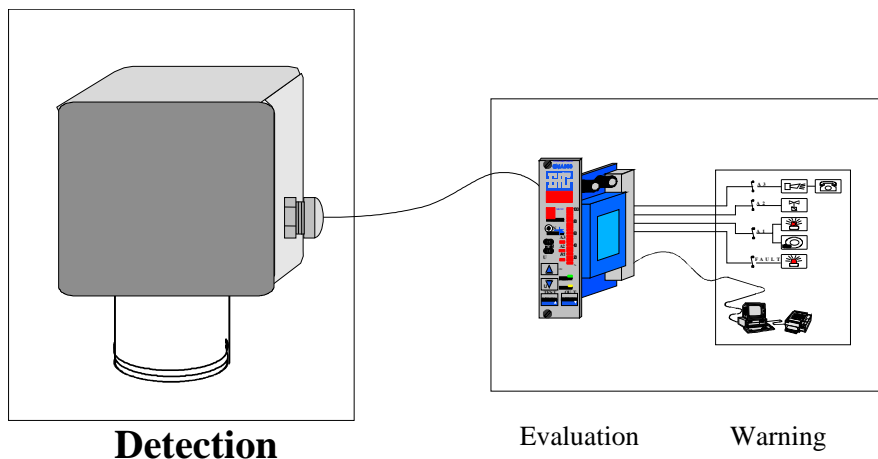

Fig. 1

The CS21 is an "intelligent" transmitter. Its comprehensive electronic circuitry allows easiest handling and servicing and increases the measurement reliability and accuracy. The CS21 is characterized by following features:

- Easy calibration at site.
- Long sensor life.

Detection Principle

The CS21 is operated on the chemosorption principle. The basic element is a sensor, which is different depending on the application and the gas to be monitored. As long as there is no gas in the ambient air, the internal resistance of the sensor is rather high. As soon as gas is adsorbed at the sensor surface, the internal resistance is reduced. The change in resistance is the measure for the gas concentration and is converted to a standardized current signal (0.2 .. 1 mA or 4 .. 20 mA) by the integrated electronic circuit. The chemosorption principle has proven a good long-term stability and, depending on the sensor design, a good selectivity.

Operational Notes

Before shipment, the CS21 passes a function and display test, being calibrated with suitable test gases. **This does not, however, overrule the obligation to arrange for another function test after putting the transmitter in operation.**

Design

The design of the CS21 is shown in Fig. 2. The sensor is mounted in the sensor support (pos. 5). The gas enters the sensor chamber through the diffusion inlet (pos. 6). The casing (pos. 2) includes a resin encapsulated p.c. board with electronic components. The electronic circuit on the p.c. board converts the measurement signal into the output of 0.2 .. 1 mA or 4 .. 20 mA, which is supplied to the evaluation unit by means of the transmitter cable.

CS21 – Design

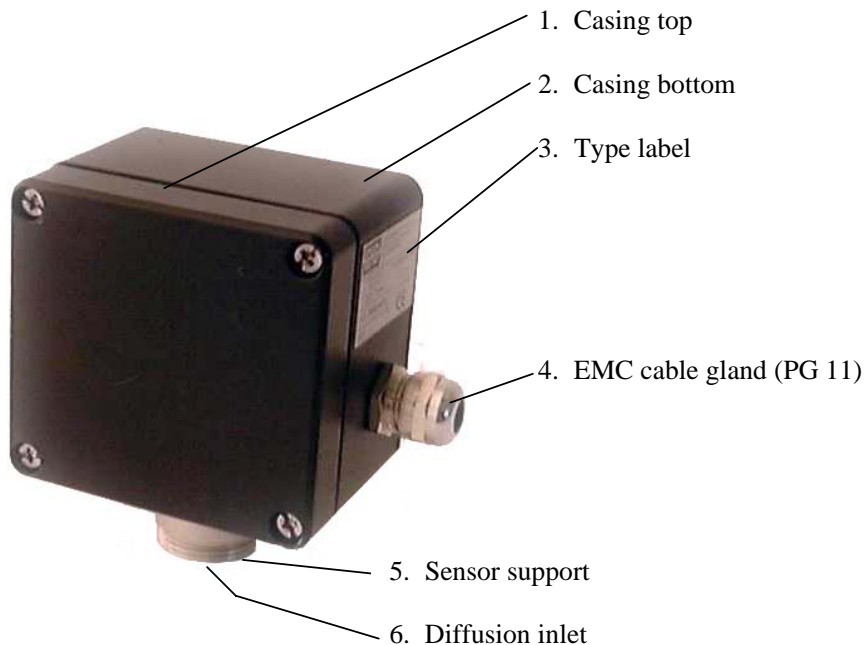

Fig. 2

CS21 Schematic

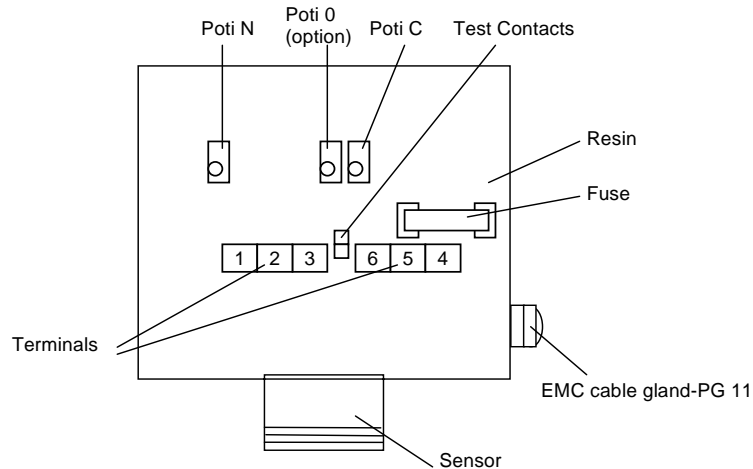

Fig. 3

Mounting Position of CS21

It is essential to exactly know the ambient conditions, which have to be taken into consideration before deciding on the mounting position. To achieve representative measurement results, take care of

- the **room ventilation and**
- the **gas density,**
- the **danger highlights.**

Install the CS21 at a place where the gases pass the sensor even in case of bad ventilation. If necessary, use a smoke cartridge to check.

Furthermore, take the following into consideration as well:

- **Ambient temperature,**
- **Rain, hose water, dripping water, condensate and**
- **Dust in the atmosphere.**

The CS21 is to a great extent protected against the entering of water and dust (IP 54). Special accessories are available to provide additional protection for very difficult conditions. Please contact GfG for detailed information.



Warranty may be voided, if the transmitter is exposed to ambient conditions that were unknown to GfG during planning, production or delivery.

When deciding on the mounting position, make sure that the transmitter is easily accessible for service and calibration. Mount the transmitter with the sensor support showing to the floor, to facilitate service and maintenance. A different mounting position, however, does not affect the sensor accuracy.

Mounting

The CS21 is connected to the controller according to the connection diagram (please also refer to the terminal diagram of your GMA controller). For mounting the transmitter remove the four special screws and take the casing top off. Fix the casing by means of two screws through the relevant borings. Inside the casing you see a resin encapsulated p.c. board with electronic components. The optional potentiometer **0** is factory-set and **MUST NOT** be turned.



Installation of Electrical Connections

A specialist must do procurement of cable and electrical connections only, obeying the applicable regulations. Depending on model or operation of the transmitter CS21, installation has to be done using a shielded 3-core 18 AWG cable.

Connections

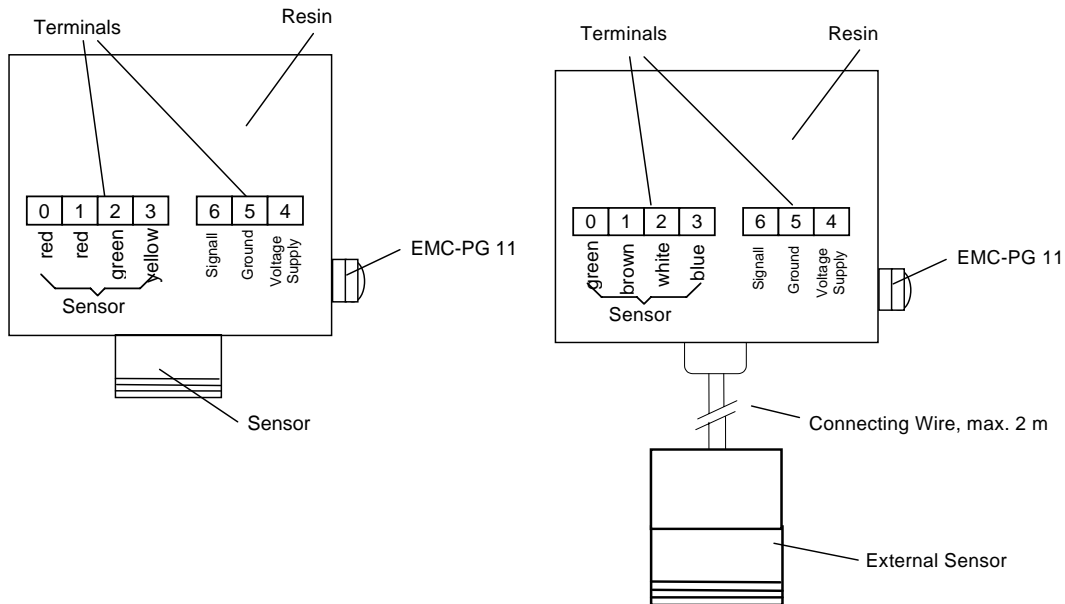
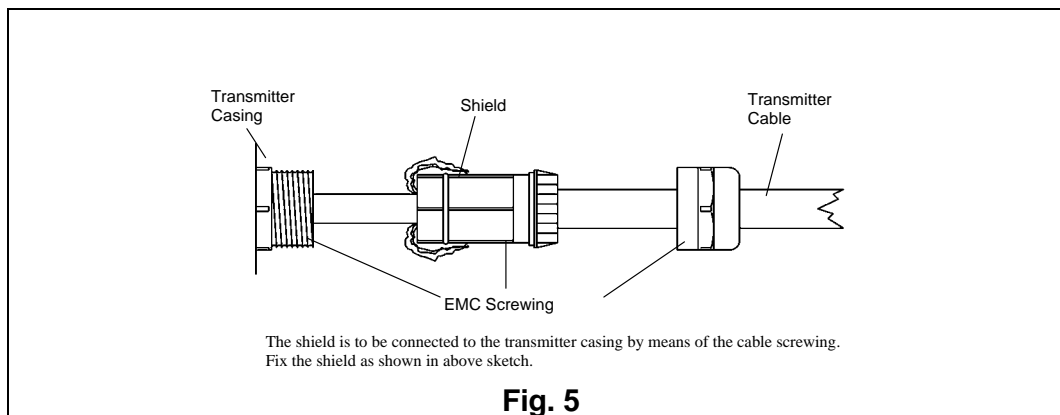

Fig. 4

The supply voltage for the transmitter (terminal 4) is 10 .. 32 V DC.
Once the installation is completed, close the casing top and fix it with the screws.

Note: Shielding is done over the EMC cable screwing.



Putting in Operation

Once the CS21 is installed, a skilled person can put it in operation. Before shipment, the CS21 has been calibrated and tested after a running-in time of several days. You do not have to wait for so long, but once you have started your new CS21, the chemosorption sensor needs a certain running-in time of approx. 15 - 30 minutes before you can check the sensitivity. Should you notice that a re-calibration is required, allow the transmitter to warm up for about 4 hours.

Check of electrical zero point

The CS21 is calibrated and tested before shipment. Certain deviations, however, are possible due to transport, mounting and ambient conditions.

Inside the CS21 there are two test contacts (fig. 3) to check the electrical output signal. The voltage at the test contacts can be measured by means of a voltmeter.

After the warm-up time of approx. 30 minutes, the signal must be approx. 197 mV, this corresponds to an output current of 4 mA (4 .. 20 mA interface). In case of deviation it is possible to re-adjust the value by turning potentiometer **0**

Check of Electrical Dead Band (Should not be adjusted without GFG authorization)

The CS21 is calibrated and tested before shipment. Certain deviations, however, are possible due to transport, mounting and ambient conditions.

Inside the CS21 there are two test contacts (fig. 3) to check the electrical output signal. The voltage at the test contacts can be measured by means of a voltmeter.

After the warm-up time of approx. 30 minutes, the signal must be approx. 200mV for zero gas *. This corresponds to an output current of 0.2 mA (0.2 .. 1 mA interface) respectively 4 mA (4 .. 20 mA interface). In case of deviation it is possible to re-adjust the value by turning potentiometer **N**.

Alternatively, for example when using a GMA controller, you can check the transmitter signal at the controller. After the warm-up time of approx. 30 minutes, you can read the zero point voltage at the controller resp. check with a voltmeter (please read the operation manual of your GMA controller). In case of deviation you can correct it at the controller.

Check of Sensitivity

To check the sensitivity of the CS21 fix a calibration adapter to the diffusion inlet of the transmitter. Then select a suitable test gas, taking into consideration, which gas has been used for initial calibration of the transmitter. You can see this information from the test report. The test gas concentration should be at least 20 % above the second alarm threshold. The basic adjustment can be seen from the test report.

* In this case, zero gas is not fresh air but test gas with 30 ppm of the gas to be monitored in air

Use a multimeter to check the output signal by measuring the voltage at the test contacts. The voltage is proportional to the output current. 200mV correspond to an output current of 0.2 mA (0.2 .. 1 mA interface) resp. 4 mA (4 .. 20 mA interface). 1000mV correspond to an output current of 1 mA (0.2 .. 1 mA interface) resp. 20 mA (4 .. 20 mA interface).

In case of deviation you can correct the value by turning potentiometer **C**.

Alternatively, for example when using a GMA controller, you can check the transmitter signal at the GMA. After the warm-up time of approx. 30 minutes you can read the signal voltage at the controller or check it with a voltmeter (please read the operation manual of your GMA). Should you notice a deviation, you can correct it at the GMA.



Do not use a test gas with a balance of nitrogen

You must use an inline humidifier, and a ½ l/min. valve with test gas.

For measurement accuracy it is important to use the end range gas to calibrate the CS 21.

Adhere to the following procedure for checking the sensitivity:

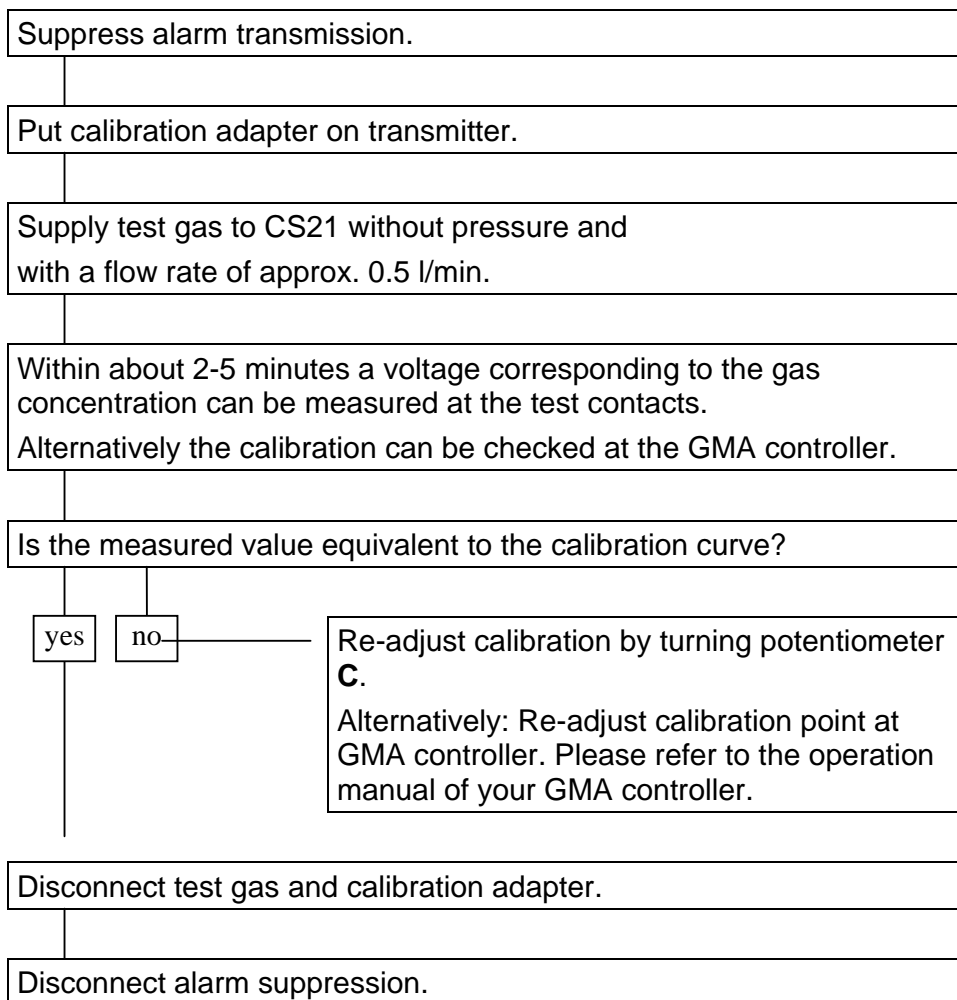

Service

This function checks:

- Check with alarm gas concentration
- Check of zero point and sensitivity (calibration)
- Check of response time
- Check of gas sampling and gas processing system (if any)
- Check of alarm signal activation
- Check of failure alarm

An expert, who has to report the result in written form, must do the check. Generally the calibration intervals should not exceed 16 weeks. The function check is to be done before putting the system in operation, and it has to be done at least once a year.

Maintenance and Inspection

Maintenance and inspection mean measures that ensure the planned status of the gas monitoring system. The CS21 does not require special maintenance, a few points should be obeyed yet.

Depending on the ambient conditions, gas monitoring systems may show a different behavior. It is important, therefore, to do a visual check every day, particularly during the first few days after putting in operation.

- Check of gas processing system and filters (if any).
- Check of gas supply for soiling or obstacles (for correct measurement the gas supply to the sensor must not be blocked).
- Sensors are subject to ageing and exhausting. Depending on their type and on their exposure to gas they are more or less used up, so a sensitivity check can only be done with a suitable test gas after certain periods. The sensitivity calibration is an expert calibration and is usually done by GfG service or by authorized persons.

Trouble Shooting

Failure	Reason	Solution
Zero point cannot be adjusted	Faulty sensor	Replace sensor
Full scale value cannot be set	Faulty sensor	Replace sensor
Output current has fallen to 0 mA	Defective fuse Defective electronics Faulty sensor Cable cut	Replace fuse Replace p.c. board Replace sensor Re-fix connection

Spare Parts

Casing top

Part No.
2211301

Accessories

Screw-on calibration adapter

Part No.
2000209

Connection Diagram CS21 / Built-in Sensor

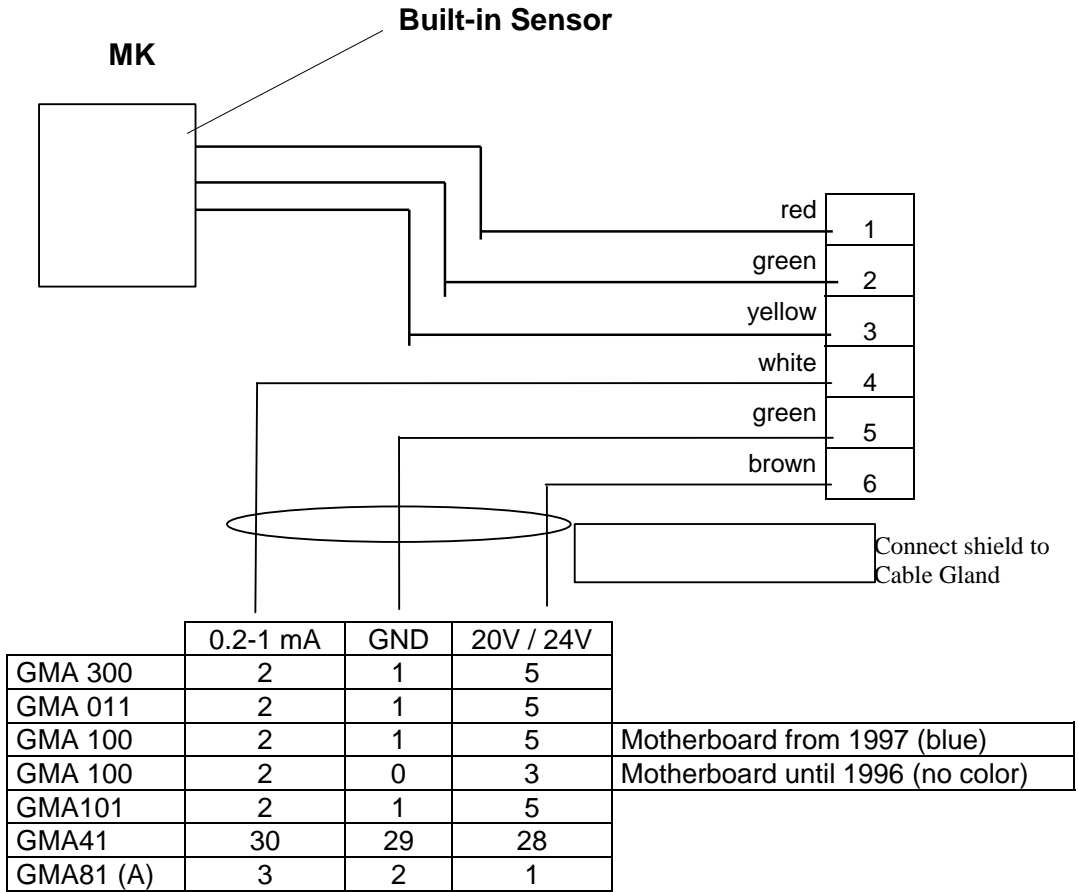

Connection Diagram CS21 / External Sensor

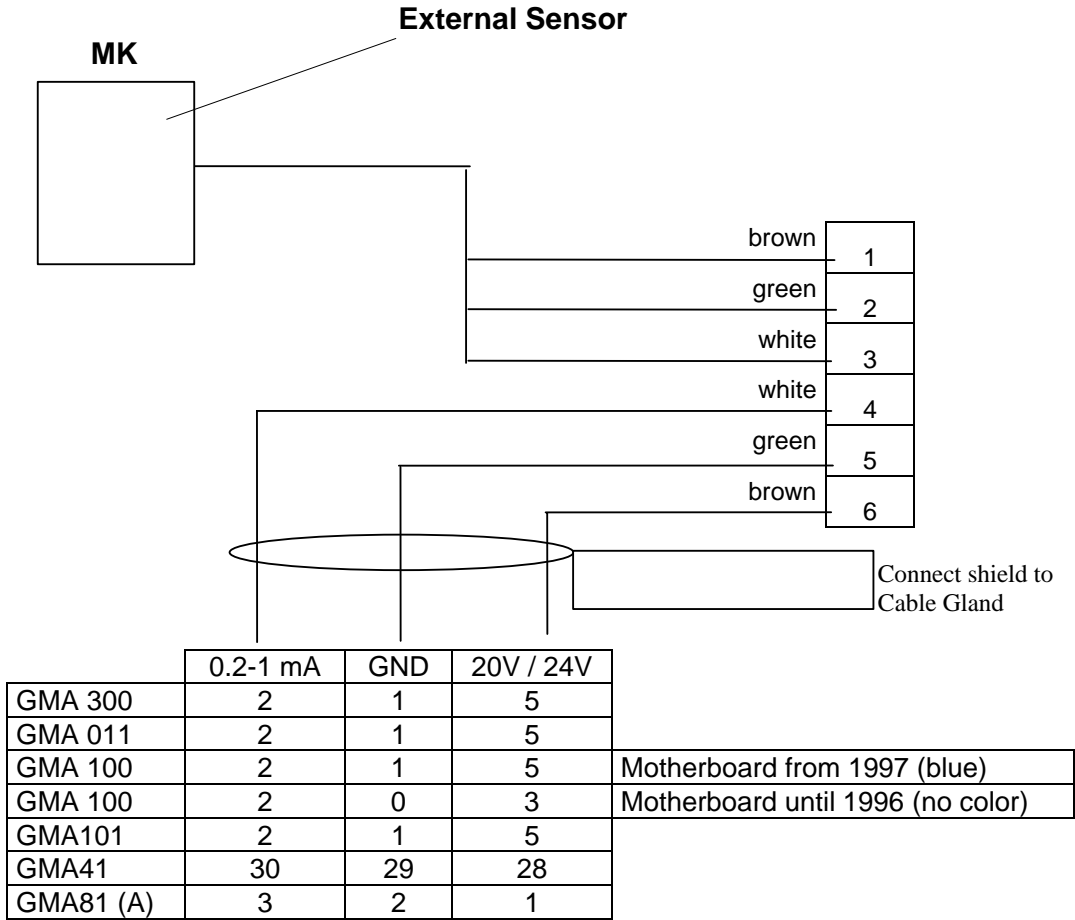

Technical Data

Transmitter CS21

Type: CS21
Sensor Type (MK): see test report
Gas: See test report
Range: see test report
Gas Supply: Diffusion
Detection Principle: Chemosorption (CS)
Supply Voltage: 10 .. 32 V DC
Output Current: 0.2 .. 1mA (4k Ω) or 4 ..20mA (200 Ω)
Response Time t_A : < 14 s (depending on gas)
Typical Sensor Life: > 5 years

Climate Conditions

Operational Temperature: - 30 .. + 55 °C
Humidity: 20 .. 96 % r. h., non condensing
Atm. Pressure: 920 .. 1100 hPa

Casing

Material: Aluminum
Protection: IP 54
Cable Gland: PG 11 screwing, max. cross section 3 x 1.5 mm²
Transmitter Cable: Shielded cable - #18/3 shielded or Belden 8770 equal
Dimensions: 100 x 100 x 57 mm (WxHxD)
Weight: approx. 370 g



GfG Instrumentation

1194 Oak Valley Drive, Suite 20
Ann Arbor, Michigan 48108
United States of America

Phone: (800) 959-0329 or (734) 769-0573

Fax (734) 769-1888

E-mail: info@gfg-inc.com

Website: www.gfg-inc.com