

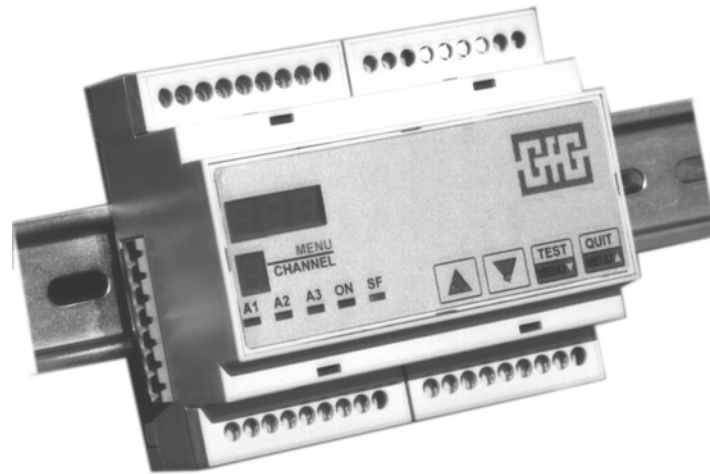

GfG Instrumentation
Worldwide Supplier of Gas Detection Solutions

GMA44

Operation Manual



Content

Introduction	3
Application	3
Distinguishing the Types of GMA44	3
For your Safety	4
Detection Mode	4
Front View GMA44	4
Function Description	4
Turning On	4
Detection Mode	5
Check of Display, Parameter and Relays	5
Alarm configuration	5
Fault	7
Relays	7
Service	8
Display of Sensor Signal	8
Recognition of the service mode of a transmitter	8
Activation of Service Mode	8
Adjustments in Service Mode	9
Adjustments in service menu A	9
Setting of Alarm Thresholds	9
Check and adjustment of Zero point	10
Check and adjustment of sensitivity	10
Adjustments in service menu B	11
Alarm threshold hysteresis	11
Activation / Deactivation of different channels	12
Storing of Changed Parameters and Leaving the Service Mode	12
Maintenance	13
Service, Inspection, Calibration and Adjustment	13
Regular Function test	13
Repair	13
Influence of Interfering Gases and Oxygen	14
Instruction for Installation and Putting into Operation	14
Transmitter Cable	14
Accessories	14
Remarks concerning the Technical Safety of the GMA44	15
Trouble Shooting	15
Spare parts	15
Service Address	15
GMA44 - Gas List	15
Terminal Plan - GMA44	17
Technical Data	18
Terminal Diagram of Transmitters	19

Introduction

Each detection point of your fixed gas monitoring system consists of a transmitter and a controller GMA44. The GMA44 allows to connect up to four transmitters of the same type. Transmitters and GMA44 are connected by means of transmitter cable. The GMA44 provides the power supply for the connected transmitters and receives and processes the sensor signals. Depending on the transmitter type, it monitors the ambient air for the presence of toxic or combustible gases and vapors or for its oxygen content. The GMA44 offers a variety of features, which allow for adapting the gas monitoring system to your specific requirements:

- 3 digit display of the linear measurement values.
- Menu display.
- 3 variably adjustable alarm thresholds.
- Adjustable relay functions: NC/NO contacts, closed circuit or open circuit operation.
- Alarm hysteresis prevents „relay fluttering“.
- Activation / Deactivation of specific measurement channels

The GMA44 continuously provides information on the measured gas concentration, exceeded alarm thresholds and its operational status. As soon as the gas concentration at one of the connected transmitters exceeds one of the three pre-set levels, the GMA44 gives a warning by means of the LED displays and controls the relevant alarm relays.

The GMA44 is easy to operate and maintenance-free. Should unexpected failures or system faults occur, the automatic failure recognition of the GMA44 allows a quick and specific service.

Application

In combination with one or up to four transmitters the GMA44 forms a fixed gas warning system for “quasi-continuous” monitoring (see section detection mode) of gas concentrations in ambient air and warning from combustible gases and vapors in the LEL range, toxic gases and oxygen.

Distinguishing the Types of GMA44

GMA Type	Transmitter Type	Built-in 230V mains unit	Supply voltage	Bus system
GMA44	all	no	24 V DC	no
GMA44 EC	EC 24, EC 25 (0.2 ..1 mA)	yes	230 V AC / 24 V DC	no
GMA44 B	all	no	24 V DC	yes
GMA44 ECB	EC 24, EC 25 (0.2 .. 1 mA)	yes	230 V AC / 24 V DC	yes

The voltage supply of the controllers GMA44 EC and GMA44 EC B are specially designed for operating an electrochemical sensor. For all other transmitters you have to use the controllers GMA44 or GMA44 B.

The pluggable bus system of the controllers GMA44 B and GMA44 EC B allows to easily interlink several GMAs. The following signals are fed in the bus system:

- 24 V supply voltage
- Signal for alarm 1, alarm 2, alarm 3, fault

The key-operated switch can only be operated in combination with the GMA44 B or GMA44 EC B.

For your Safety

This manual must be carefully read by all individuals who have or will have the responsibility for using and servicing this product. As any piece of complex equipment, the GfG GMA44 will do the job designed to do, only, if it is used and serviced in accordance with the manufacturer's instructions. The warranties made by GfG with respect to the product are voided, if the adjustment of functions or parameters is changed without GfG's permission. They are also voided, if the product is not used and serviced in accordance with the instructions in this manual. The above does not alter statements regarding GfG's warranties and conditions of sale and delivery.



Notice:

For the parameter setting of the supplied GMA44 please refer to the test report. Modification of functions or parameters may affect the approval. GfG service is always at your disposal for adapting the monitoring system to your specific requirements.

Detection Mode

Front View GMA44

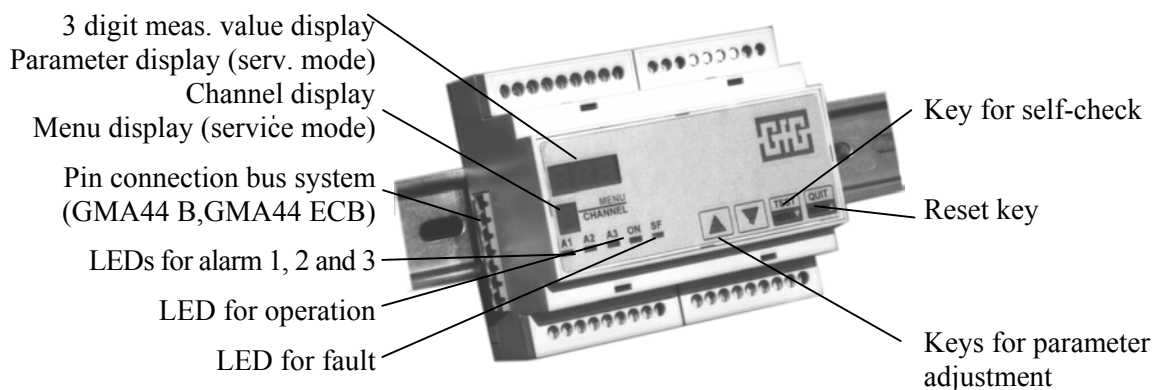

Function Description

Turning On

After having turned the system on, allow a few minutes for:

- the self test, which checks functions, memory (ROM and RAM) and parameter memory (approx. 10 seconds),
- the warm-up of the transmitters connected (for detailed information please refer to the operation manual for your transmitter).

During the warm-up period the GMA44 displays the detection range, the detection unit and the alarm thresholds one after the other. The LED „ON“ blinks and the LED „S F“ is lit, i.e. the fault alarm is active. There are no gas alarms during the warm-up period. When the GMA44 re-starts after a mains failure, the gas alarms are only evaluated, once the warm-up is completed. Then the GMA44 automatically turns to detection mode.

Detection Mode

During the detection mode the activated 3 digit LED display shows the current gas concentrations of the individual transmitters one after the other (the display of the measurement values can get deactivated. Please ask for GfG's Service). The channel display indicates, which transmitter is displayed. All channels are monitored quasi-continuously. Exceeded threshold values are recognized and reported immediately. Electronic functions, like parameter memory and transmitters, are continuously monitored. In trouble-free detection mode the green LED „ON“ is lit and the yellow LED „S F“ is out.

Check of Display, Parameter and Relays



During this check the measurement and warning function is not activated!

LED Test

In detection mode, press key  shortly to activate the self-test of the GMA44 controller. A successful self-test is indicated by the flashing of all LEDs.

Display of Detection Range and Alarm Thresholds

Keep key  pressed for approx. 5 seconds. The LED „ON“ blinks and the display reads the below mentioned parameters one after the other:

	Display, e.g.	LED ON - blinks, additionally lit:	Description of Display
1	100, 50, 10		Detection range
2	UEG, LEL, ppm, ppb		Unit of gas
3	CH ₄ , NH ₃ , O ₂ GfG-Gas No.		Gas
4	20 (value in det. range)	A1	1. Threshold alarm
5	40 (value in det. range)	A2	2. Threshold alarm
6	40 (value in det. range)	A3	3. Threshold alarm

Once these readings are complete, the GMA44 turns to detection mode automatically.

Alarm configuration

The GMA 44 has 3 alarm thresholds.

Max. number of channels	Kind of alarm	Alarm per channel	Assignment
4	Collective alarm	3	alarm 1 { channel 1 channel 2 channel 3 channel 4 } alarm 2 { channel 1 channel 2 channel 3 channel 4 } alarm 3 { channel 1 channel 2 channel 3 channel 4 }

The GMA44 provides 3 threshold alarms, which act as a collective alarm for all connected transmitters. An alarm is activated as soon as the gas concentration exceeds or falls below the alarm threshold. An activated alarm is indicated by means of the relevant alarm LED. Press key  to acknowledge the alarm. During this time newly activated alarms get acknowledged too.

Alarm	Relevant Alarm LED
has been activated	blinks
has been activated and acknowledged by pressing key 	lights permanently

Together with the alarm LEDs the GMA44 activates the relevant alarm relay and the logical output. The standard setting for the switching functions is shown below:

Alarm	Function	Resettable during Alarm	Resettable after Alarm	Remark
1	non-latching	no	self deleting	
2	non-latching	no	self deleting	
3	non-latching	no	self deleting	Same threshold as alarm 2



The switching functions of the three alarms can be set individually. Alarm thresholds and switching functions are the same for all 4 channels. For other settings than the standard one please refer to your test report.

By pressing key  during an alarm, the status of the corresponding channel can be seen from the LEDs.



During the test the measuring and warning functions are not activated!

Over range Memory

In case the detection range is exceeded by more than 10 %, the GMA44 activates the fault indication in addition to the 3 gas alarms. The display reads . All alarms and the fault indication are, in this case, latching, i.e. they can only be reset by pressing key , when the gas concentration has fallen below the full scale value.



The switching functions of the three alarms can be set individually. Alarm thresholds and switch function are the same for all 4 channels. For settings, which are different from the standard adjustment, please refer to the test report.

Remarks concerning Alarm Functions:

Exceeding / Deviating Alarm

If the reduction of the measured gas concentration means a hazardous situation, e.g. oxygen deficiency, the alarm is a deviating one. Exceeding alarms indicate a dangerous situation caused by rising gas concentrations, e.g. toxic and combustible gases.

Latching / Non-latching Alarm

A latching alarm remains valid until it is reset externally, e.g. by pressing key  at the GMA44. By pressing key  an activated alarm is, after having passed all measurement channels, acknowledged. During this period newly activated alarms are being acknowledged as well. A non-latching alarm resets automatically, when the gas concentration falls below or exceeds the preset threshold.

Fault

In case of failure the yellow LED „**S F**“ lights up and the fault relay is activated. A fault is signalized:

- if the cable between transmitter and GMA44 is cut;
- if the sensor or the circuit of the transmitter is faulty;
- if the zero point is deviated;
- if the detection range is exceeded (together with alarm activation);
- if the CPU self monitoring is faulty.

As soon as the fault is over, the yellow LED “SF” goes out. The fault relay switches back and the controller goes back to the normal operation.

Relays

The GMA44 provides 4 relays:

- 3 alarm relays for controlling external alarm devices,
- 1 fault relay for signaling of failures.

The switching behavior of the relays is the same as for alarm or fault signals. Every relay can be operated as NC or NO contact in closed or open circuit systems. For the switching functions as NC and NO relays you will find contact clamps. In the standard setting all 4 relays are NO contacts. The alarm relays are operated as open circuit system, the fault relay is a closed circuit.

In the standard setting the switching functions of the relays are as follows:

Relay for:	The relay switches:							
	in detection mode (no gas)	during gas alarm not reset	during gas alarm reset	after gas alarm not reset	after gas alarm reset	in case of mains failure	in case of failure	in case of gas alarm and failure
Alarm 1								
Alarm 2								
Alarm 3								
Fault								

Ö = open
S = closed





It is essential to take notice of the switching behavior of the relays when connecting external devices. In the standard setting alarm 3 (buzzer relay) can be reset even during gas alarm!

For special settings of the relay switching functions please contact your GfG service.

Service

Display of Sensor Signal

Press key  for approx. 2 seconds, and the GMA44 display reads the signals, coming from the transmitter, in mA (0,2 .. 1 for transmitters with 0,2 .. 1 mA output and 4 .. 20 mA for transmitters with 4 .. 20 mA output). You will always see only that channel, which was displayed when you pressed the key. This channel is kept until you release key . This function allows to check the zero point of the connected transmitters quickly and easily at the GMA44.

Recognition of the service mode of a transmitter







This function is only supported by the transmitters CC 24 EX (type 243x II), CS 24 EX (type 247xII) and EC 25 (type 250x).

The transmitter CC 24 EX, CS 24 EX, EC 25 all have a service switch. If this switch is pressed for service operations (see manual of the transmitter), the GMA 44 displays a fault alarm. No alarms are passed on.



Activation of Service Mode

The service menu allows for displaying and changing of all important parameters of the GMA 44.

A security code protects the service mode A and B from accidental maladjustment and unauthorized access. Adhere to the following procedure to enter the service mode:



1. Press key , then key  and keep both keys pressed, until „SER“ is read in the display.
2. Use keys  and  to enter the security code.

	Security Code	Adjustments
Menu A	11	Alarm thresholds and adjustment
Menu B	222	Deactivation points of alarm thresholds





3. Press key  to confirm the entered security code.
The GMA44 turns to service mode
or
Press key  to return to detection mode.

In the service mode the gas alarms are locked, new alarms cannot be activated. The GMA44 switches to fault. The LED „ON“ and „S F“ light up, the fault relay is activated



The service mode switches into operation mode, if the keys  and  are simultaneously pressed and the service mode is left with storage or non-storage (see storage of changed parameters and leaving the service mode).









Adjustments in Service Mode

The display of the GMA44 reads the set parameters. The menu display indicates the menu point, where the displayed parameter value can be found. Use keys  and  to scroll forward and back. For changing of parameters use keys  and .





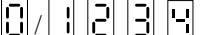



Survey of Menu Points

Menu A				
Menus display	Channel	Description	Display, e.g.	Parameter Setting
		Relay test	r1	

The menu starts with "G1"



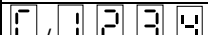



	all	Measurement unit	LEL, ppm	Only display
	all	Gas	CH ₄ , NH ₃ , O ₂ or GfG-Gas No.	
	all	Threshold alarm 1	Value in detection range	Adjustment with  and 
	all	Threshold alarm 2	Value in detection range	
	all	Threshold alarm 3	Value in detection range	
	1 to 4	Zero point adjustment	0 *	
	1 to 4	Sensitivity adjustment	Value in detection range *	

* Parameter display --- if channels are activated. Adjustment of parameters is not possible.

Menu B				
Menus display	Channel	Description	Display, e.g.	Parameter Setting
	all	Point of deactivation for alarm 1	Value in detection range	Adjustment with  and 
	all	Point of deactivation for alarm 2	Value in detection range	
	all	Point of deactivation for alarm 3	Value in detection range	
	1 to 4	Activation of channel	on	
	1 to 4	Deactivation of channel	off	

Adjustments in service menu A

Setting of Alarm Thresholds

1. Activate the service mode A.
2. Use keys  and  to select menu point ,  or  for the alarm threshold to be set.
3. Set the new alarm threshold by means of keys  and .
4. Store the parameters. (see page 13)

Check and adjustment of Zero point





1. Supply zero gas to the transmitter or make sure, that the ambient air is free from interfering gases. Zero gas is a test gas, which is free from combustible or any other interfering components. For details about the gas supply please refer to the operation manual of your transmitter.
2. Wait until the display value is stable. Then press key  for 2 seconds to check the sensor signal. An adjustment of the zero point is only possible, if the sensor signal is within a tolerance band:

For a transmitter with 0.2 - 1 mA: Tolerance of 0.15 - 0.34 mA

For a transmitter with 0.4 - 20 mA: Tolerance of 3 - 6.8 mA

(Slightly different tolerances are possible).

If the zero-point is out of tolerance, the zero point has to be adjusted at the transmitter first. For this, please read the manual of the transmitter.





3. Activate the service mode A.
4. Use keys  and  to select menu point  of the current channel.
5. Press  key for 3 seconds to adjust the zero point automatically. The adjustment of the zero point was successful, when the value „0“ is flashing in the display. If the display is not flashing, the sensor signal was out of tolerance and has to be adjusted at the transmitter first. Please refer to the operation manual of your transmitter.
6. Disconnect the zero gas from the transmitter. In case of transmitters for oxygen wait until the displayed gas concentration exceeds the threshold alarm.
7. Store the parameter (see page 13).

Check and adjustment of sensitivity

Note: Before you can check the sensitivity, make sure that the zero point is set correctly.

The GMA 44 allows for the check and adjustment of sensitivity with the help of the peak value memory. The memory activates itself, after the menu setting  of the respective channel has been activated for at least 2.5 minutes. The GMA 44 displays the activated peak value memory by a flashing display.

Check and adjustment of sensitivity without peak value memory

1. Activate the service mode A.
2. Use keys  and  to select menu point  of the current channel.
3. Supply test gas to the transmitter. For details about the gas supply please refer to the operation manual of your transmitter.
4. Wait until the display value is stable.
5. Use keys  and  to set the parameter value to the concentration of your test.
6. Disconnect the test gas supply from the transmitter. In case of transmitters for toxic or combustible gases wait until the displayed gas concentration falls below the threshold alarm.
7. Store the parameter (see page 13).

Check and adjustment of the sensitivity with peak value memory

This adjustment method uses the possibility of the GMA 44, to store the highest signal value, which has been measured during the test gas supply. The stored maximum values can be used as sensitivity point. Figure 2 shows this procedure:

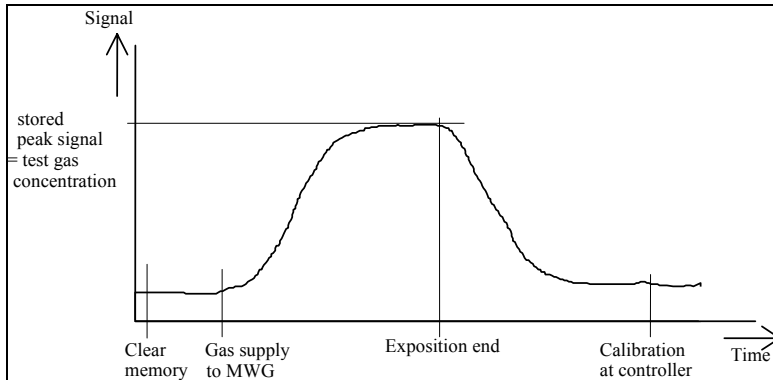

1. Activate service **menu A**.
2. Use keys **TEST MENU** and **QUIT MENU** to select menu point **[]** of the respective channel.
3. After 1.5 minutes supply test gas to the transmitter and make sure that the gas is supplied constantly for at least 3 minutes. For details about the gas supply please refer to the operation manual of your transmitter.



The test gas supply needs to be done timely before the starting the storage. Thereby wrong measurement values through the increase in pressure when opening the pressure gauge of the test gas bottle are avoided. For further detail concerning the gas supply of the transmitter please refer to the manual of the connected transmitter.

4. Disconnect the test gas source from the transmitter.
5. Use keys **[▲]** and **[▼]** to set the parameter value to the test gas concentration.
6. Store the parameter (see page 13).

Adjustments in service menu B

Alarm threshold hysteresis







This function allows for adjusting the hysteresis (point of deactivation) of the alarm thresholds. For exceeding alarms this point can be set from the start of the detection range up to two digits below the alarm threshold. For deviating alarms the deactivation point can be set from two resolution units above the alarm threshold up to the end of the detection range. The parameter setting is done in the unit of the gas to be measured.

Example:

The hysteresis of a controller, which monitors gas in the LEL range, was set to 18 % LEL for alarm 1, 36 % LEL for alarm 2 and 54 % LEL for alarm 3. This results in the alarm activation below:

	Alarm 1	Alarm 2	Alarm 3
Alarm threshold	= 20 % LEL	= 40 % LEL	= 60 % LEL
Alarm activation	≥ 20 % LEL	≥ 40 % LEL	≥ 60 % LEL
Alarm deactivation	≤ 18 % LEL	≤ 36 % LEL	≤ 54 % LEL









Adjustment of deactivation point:

1. Activate service **menu B**.
2. Use keys  and  to select menu point ,  or  for the alarm deactivation point to be set.
3. Use keys  and  to adjust the new deactivation point.
4. Store the parameter (see below).

Activation / Deactivation of different channels

With this function different channels can be activated or deactivated. This makes sense, if a defect transmitter needs to be taken out of the monitoring system for inspection or if, for the time being, only 2 measurement points shall be established and only later further measurement points shall be activated.

Activation / Deactivation

1. Activate service menu B.
2. Use keys  and  to select menu point  for the respective channel , ,  or .
3. The desired channel gets activated with key  and deactivated with key .





A deactivation of all channels is not possible. At least one channel is always activated.

4. Store the parameter (see below).

Storing of Changed Parameters and Leaving the Service Mode

All changes done in the service mode have to be stored:

1. Press keys  and  simultaneously to activate the memory function.
The display reads „Sto“.
2. **Confirm storage:** Press key  to confirm the storage of the parameter.
The GMA44 stores all changed parameters and returns to detection mode.



When you store the changes when leaving menu B, all activated alarms and fault reports are deleted.

or

No storage: Press key  and the GMA44 returns to detection mode without storing the changed parameters.



You can change several parameters one after the other, without storing them individually. Once you have set all parameters, one storage confirmation is sufficient to store all changed parameters.

Maintenance

Function tests must be done before putting into operation and at least once a year, and checks:

- the zero point and the sensitivity (calibration)
- the response time
- the activation of gas and fault alarms

This test has to be done by an expert, and a written result must be filed.

Service, Inspection, Calibration and Adjustment

During the inspection visual checks shall be carried out.

- Pollution by dust
- Condensation by humidity
- Protective casing of transmitters
- Diffusion inlets of transmitter

Service and adjustment describe those measures, which retain the nominal status of the gas warning system. Those measures shall be carried out on a regular basis, an interval of 4 months shall not be exceeded.

- Zero point
- Sensitivity
- Alarm activation
- Follow-up time
- Audible and visible output
- Fault report

Regular Function test

In addition to the maintenance the functioning of the controller has to be tested on a regular basis. Intervals of 1 year may not be exceeded.

Repair

Repair describes all repair works and exchange of parts. They may only be carried out by the manufacturer or persons who have been authorized by him. Only those original spare parts that have been tested and have been allowed to be sold by the manufacturer may be used.



If these measures are neglected, the safety of the product cannot be guaranteed the type approval is lapsed.

We recommend to regularly carry out function tests and repairs through GfG service.

Influence of Interfering Gases and Oxygen

Interfering gases, oxygen surplus and oxygen deficiency can also affect the measurement of gases at the transmitter. Please adhere to the operation manual of your transmitter.

Instruction for Installation and Putting into Operation

The GMA44 controller must not be installed in hazardous areas. The transmitter and the mains supply are connected according to the terminal diagram. Make sure that the shield of the transmitter cable is already grounded close to the terminals of the GMA44 on the metal mounting plate, e.g. by means of EMC earth clips.

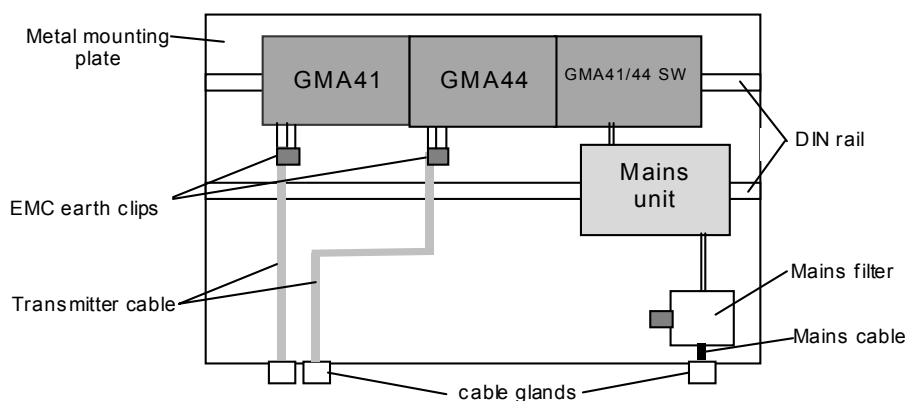

Figure 3: Wiring example

Inside the wall mount casing or the cabinet the transmitter cable should be laid separately from other control and mains cable. The mains supply for the GMA44 is generally to be fed over a mains filter (e.g. FN 610). This filter should also be mounted and grounded on a metal mounting plate close to the cable entry. Once the GMA44 is mounted into a casing and all transmitters, control groups and the mains supply are connected, an expert can put the system into operation. For installation and putting into operation of the transmitters please see the operation manual of your sensor. **Only experts are authorized to put the GMA44 and the transmitters into operation.**

Transmitter Cable

The GMA44 controller and the transmitter are connected by means of a shielded transmitter (data) cable (LIYCY). The cross section of the cable cores depends on the current consumption of the transmitter and on the cable length. For detailed information please refer to the operation manual of your transmitter.

Accessories

Key-operated Switch Module:

This module allows to control a collective alarm. In addition to this, it provides the possibility of alarm suppression, e.g. during service or maintenance.

Remarks concerning the Technical Safety of the GMA44

Contact Protection

Mains supply and relay contacts of the **GMA44** provide insulation distances of 3 mm, i.e. they are designed for 250 V operational insulation. In case a contact is operated on a contact-critical potential, the contacts close to it are also considered as contact-critical. According to contact protection the contacts are not considered to be separated safely. Resulting from this, the same applies to the relay contacts of a controller operated on 230 V. Here an operational insulation has been provided as well. The insulation of the secondary circuit from the primary circuit and the relay contacts complies with the requirements for contact protection. Distances of 6.5 mm ensure a safe separation. The secondary circuit operates on extra-low safety voltage.

Trouble Shooting

Failure	Cause	Solution
LED "S F" lights up, display „EEP“	- System error, fault in parameter memory	- Re-start of system - Call GfG service
LED "S F" lights up, LED „ON“ blinks	- System is in warm-up period, alarm suppression is still active	- Wait until warm-up period is over
LEDs do not light up	- Faulty voltage supply, defective fuse or mains unit	- Ensure proper voltage supply
Sensor signal, but gas-free atmosphere	- Incorrect calibration, incorrect zero point adjustment	- Adjust the zero point, calibrate
Display <input type="text" value="-"/> <input type="text" value="-"/> <input type="text" value="-"/> LED „S F“ lights up	- Display over range (> 999) - ADC over range - stored over range	- If there is a gas-free atmosphere at the transmitter, you can reset the stored measurement value
Display <input type="text" value="-"/> <input type="text" value="-"/> <input type="text" value="-"/> LED „S F“ lights up	- Display deviation (< -99) - ADC range deviation - Cable cut	- Check calibration of transmitter and GMA controller - Check cable

Spare parts

	Description	Part no.
1.	Primary fuse T 0,08 A (5 units)	2121301
2.	Secondary fuse T 1,25 A (5 units)	

Service Address

For additional questions on the product or in case of failure and problems please contact:

GfG Instrumentation

1194 Oak Valley Drive

Phone: 734-769-0573

Fax: 734-769-1888

E-Mail: info@gfg-inc.com

GMA44 - Gas List

Gas Nr.	Gas	Chemical Formula	GMA Nr
1	Aceton	CH ₆ O	1
2	Acetonitrile	C ₂ H ₃ N	2
3	Acetylene	C ₂ H ₂	3
4	Acrylnitrile	C ₃ H ₃ N	4
5	Aminopropane	C ₃ H ₉ N	5
6	Ammonia	NH ₃	nh3
7	Amyl alcohol	C ₅ H ₁₂ O	7
8	Benzine 60/95	Mixture	8
9	Benzine 80/110	Mixture	9
10	Benzine (fuel)	Mixture	10
11	Benzene	C ₆ H ₆	11
12	Comb. gases and vapors	Mixture	12
13	Bromtrifluoromethane (Halon)	C Br F ₃	13
14	Butadien - 1.3	C ₄ H ₆	14
15	n-Butane	C ₄ H ₁₀	but.
16	i-Butane	(CH ₃) ₃ CH	16
17	Butanol - 1	C ₄ H ₁₀ O	17
18	Butanon - 2	C ₄ H ₈ O	18
19	n-Butylacetate	C ₆ H ₁₂ O ₂	19
20	i-Butylacetate	C ₆ H ₁₂ O ₂	20
21	n-Butyl alcohol	C ₄ H ₁₀ O	21
22	1-Butylene	C ₄ H ₈	22
23	Chlorine	Cl ₂	CL2
24	Chloromethane	CH ₃ Cl	24
25	Hydrogen chloride	HCl	HCL
26	Hydrogen cyanide	HCN	hcn
27	Cyclohexane	C ₆ H ₁₂	27
28	Cyclopentan	C ₅ H ₁₀	28
29	Cyclopropane	C ₃ H ₆	29
30	Dichlordifluoromethane (R12)	C Cl ₂ F ₂	30
31	1.1 Dichlorethane	C ₂ H ₄ Cl ₂	31
32	Dichlorfluoromethane (R21)	CH Cl ₂ F	32
33	Dichloromethaen	CH ₂ Cl ₂	33
34	1.2 Dichloropropane	C ₃ H ₆ Cl ₂	34
35	Diethylamine	C ₄ H ₁₁ N	35
36	Dimethylether	C ₂ H ₆ O	36
37	Epichlorhydrin	C ₃ H ₅ Cl O	37
38	Natural gas (H+L)	C _n H _m , N ₂	38
39	Ethane	C ₂ H ₆	39
40	Ethanol	C ₂ H ₅ OH	Eol.
41	Ethyl acetate	C ₄ H ₈ O ₂	41
42	Ethyl alcohol	C ₂ H ₆ O	42
43	Ethylen	C ₂ H ₄	43
44	Ethylen oxide	C ₂ H ₄ O	44
45	FAM-Benzine	Mixture	45
46	Jet fuel 40/180	Mixture	46
47	Formaldehyde	CH ₂ O	47
48	Frigen 22	CH Cl F ₂	r22
49	Helium	He	49
50	Heptane	C ₇ H ₁₆	50
51	n-Hexane	C ₆ H ₁₄	51
52	i-Hexane	C ₆ H ₁₄	52
53	Hexanon-2	C ₆ H ₁₂ O	53
54	Isobutyl acetate	C ₆ H ₁₂ O ₂	54

Gas Nr.	Gas	Chemical Formula	GMA Nr
55	Carbon dioxide	CO ₂	CO2
56	Carbon monoxide	CO	CO
57	Coke gas	CO, CH ₄ , H ₂	57
58	Air	N ₂ , O ₂ , CO ₂	58
59	Methane	CH ₄	CH4
60	Methanol	CH ₄ O	60
61	Methyl acetate	C ₃ H ₆ O ₂	61
62	Methyl alcohol	CH ₃ OH	62
63	Methylbutylketone	C ₆ H ₁₂ O	63
64	Methyl chloride	CH ₃ Cl	64
65	Methylene chloride	CH ₂ Cl ₂	65
66	Methyl-i-butylketone	C ₆ H ₁₂ O	66
67	Methylethylketone	C ₄ H ₈ O	67
68	Methylglycol	C ₃ H ₈ O ₂	68
69	Methylmethacrylate	C ₅ H ₈ O ₂	69
70	Methylpropanol	C ₄ H ₁₀ O	70
71	Monochlordifluoromonobrom.	C Br Cl F ₂	71
72	n-Nonane	C ₉ H ₂₀	non.
73	i-Octane	C ₈ H ₁₈	73
74	n-Octane	C ₈ H ₁₈	74
75	i-Pentane	C ₅ H ₁₂	75
76	n-Pentane	C ₅ H ₁₂	76
77	Pentanon-2	C ₅ H ₁₀ O	77
78	Penten-1	C ₅ H ₁₀	78
79	Pentyl acetate	C ₇ H ₁₄ O ₂	79
80	Perchloroethylene	C ₂ Cl ₄	80
81	Propane	C ₃ H ₈	Pro.
82	Propanol-2	C ₃ H ₈ O	82
83	i-Propyl acetate	C ₅ H ₁₀ O ₂	83
84	n-Propyl acetate	C ₅ H ₁₀ O ₂	84
85	n-Propyl alcohol	C ₃ H ₈ O	85
86	i-Propyl alcohol	C ₃ H ₈ O	86
87	Propylene	C ₃ H ₆	87
88	Propylenedichloride-1.2	C ₃ H ₆ Cl ₂	88
89	Oxygen	O ₂	O2
90	Sulfur dioxide	SO ₂	SO2
91	Sulfurhexafluoride	SF ₆	91
92	Hydrogen sulfide	H ₂ S	H2S
93	Town gas	CO, CH ₄ , H ₂	93
94	Nitrogen dioxide	NO ₂	no2
95	Nitrogen monoxide	NO	no
96	Styrene	C ₈ H ₈	96
97	Tetrachloroethane	C ₂ Cl ₄	97
98	Toluene	C ₇ H ₈	98
99	1.1.1-Trichloroethane	C ₂ H ₃ Cl ₃	99
100	Trichloroethylene	C ₂ HCl ₃	100
101	Trifluoromethane (R23)	CH F ₃	101
102	Vinyl acetate	C ₄ H ₆ O ₂	102
103	Vinyl chloride	C ₂ H ₃ Cl	103
104	Hydrogen	H ₂	H2
105	Water gas	H ₂ , CO, CH ₄	105
106	Xylene	C ₈ H ₁₀	106
107	Ozone	O ₃	107

Chart 1 - GfG-Gas List

Terminal Plan - GMA44

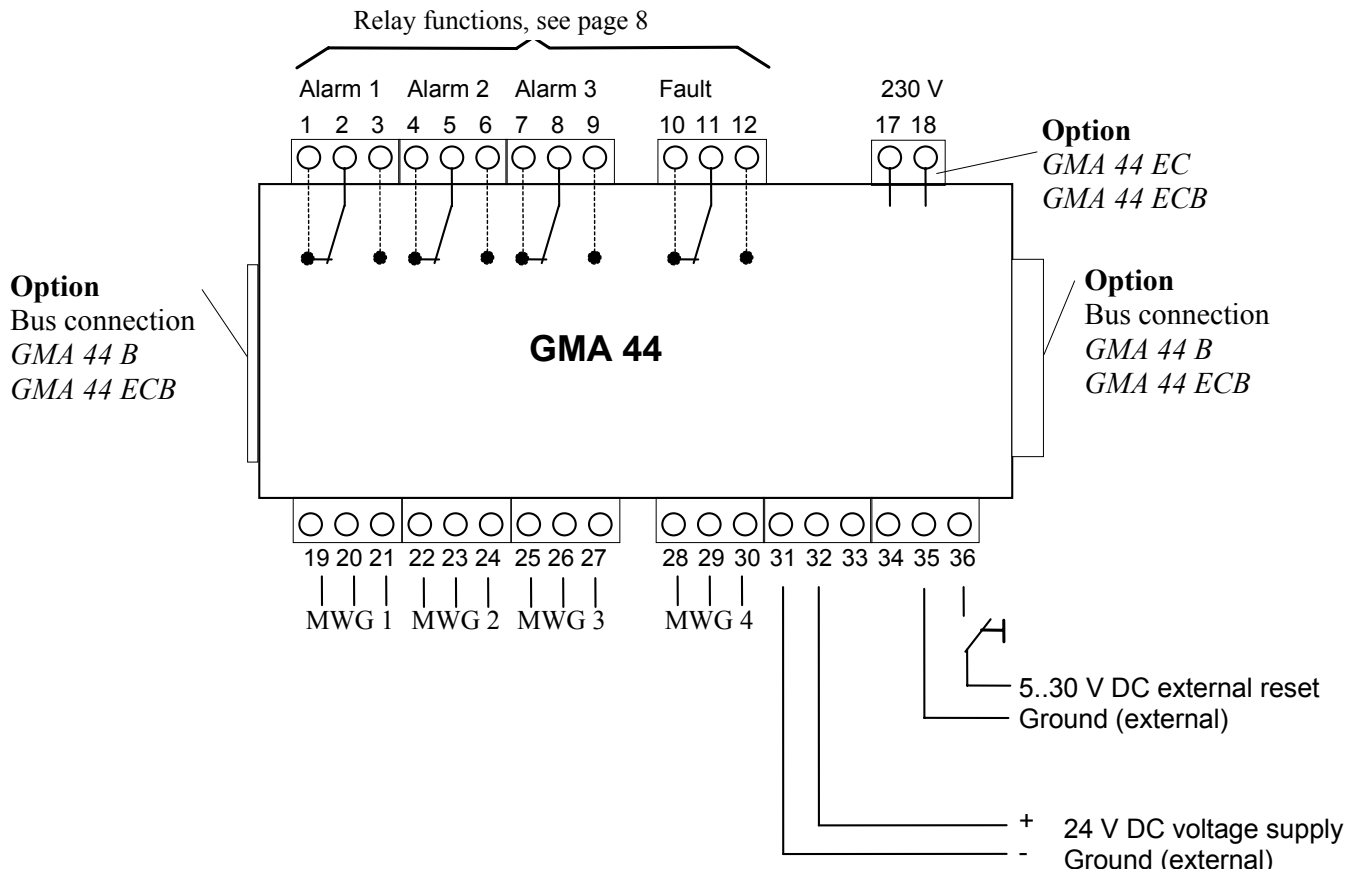

	Terminals for			
	Transmitter 1	Transmitter 2	Transmitter 3	Transmitter 4
Supply approx. 24 V	19	22	25	28
Ground	20	23	26	29
Signal 4..20 mA or 0.2..1 mA	21	24	27	30

Technical Data

Gas Monitor GMA44	for snap-on mounting on DIN-rail		
Type:	GMA 44		
Dimensions:	Height: 106 x 90 x 58 mm (WxHxD)		
Power supply			
Operational voltage:	<i>GMA44, GMA44 B</i>	24 V DC	
	<i>GMA44 EC, GMA44 ECB</i>	230 V / 50Hz or 24 V DC	
Current consumption:	max. 150 mA at 24 V DC max. 2.6 W at 230 V		
Primary fuse:	<i>GMA44 EC, GMA44 ECB</i>	T 0.08 A	G melt fuse
Secondary fuse:	<i>GMA44</i> , <i>GMA44 B</i>	T 1.25 A	G melt fuse
	<i>GMA44 EC, GMA44 ECB</i>	T 0.5 A	G melt fuse
Climate conditions			
for operation:	-10 to +55 °C, 0 to 99 % r.h. 700 to 1300 hPa -10 to +40 °C with built-in mains unit (<i>GMA44 EC and GMA44 ECB</i>)		
recommended storage conditions for GMA44, accessories, spares:	-25 to +50 °C, 0 to 99 % r.h.		
Transmitter connection			
Transmitter:	4 transmitters of the same type and detection range		
Transmitter connection:	2-, 3-wire transmitter		
Voltage supply output:	18 to 24 V DC		
Input signals:	4 .. 20 mA, 0.2 .. 1 mA		
Output signals			
Display sensor signal:	0,2 .. 1 mA	max. deviation:	0,2 .. 0,5 mA ± 0,02 mA > 0,5 mA ± 0,05 mA
	4 .. 20 mA	max. deviation:	4 .. 10 mA ± 0,4 mA > 10 mA + 1 mA
Relays:	max. switch voltage 250 V AC 50/60 Hz or 250 V DC max. switch current 4 A AC/DC max. switch performance 1000 VA AC or depending on voltage 50 .. 200 W DC Relay outputs and mains entry are operation insulated		
Logical outputs (only GMA 44B, GMA 44 ECB)	4 open collector outputs for alarm 1, alarm 2, alarm 3, fault Operation only on safety low voltage Max. switch voltage: 30 V Max. switch current: 100 mA		
External reset:	High active from 3 .. 24 V DC (input resistance 11kΩ)		
Snap-on bar fixing:	DIN EN 50022		
Safety			
Protection:	DIN 40050 - IP -20		
Protective separation: GMA44 EC, GMA44 ECB	by safety transformer type: BV EI 306 2064 PRI 230V / SEC 18 V 50 - 60HZ		
Protective insulation:	as per EN 61010 up to over voltage category III and soiling degree 2		
Certificate of manufacturer:	The GMA 44 complies with the conditions of the EMC-Regulation 89/336/EWG and the low voltage regulation 73/23/EWG		

Terminal Diagram of Transmitters

Transmitter CC 0238 EX

The CC sensor is designed as 3-wire transmitter. The supply voltage and the 0.2 - 1 mA output signal use the same ground line. Cable type: 18 gauge 3 strand shielded (up to 200 m).

For connection of transmitters 2 to 4 repeat the steps for transmitter 1 (see picture below).

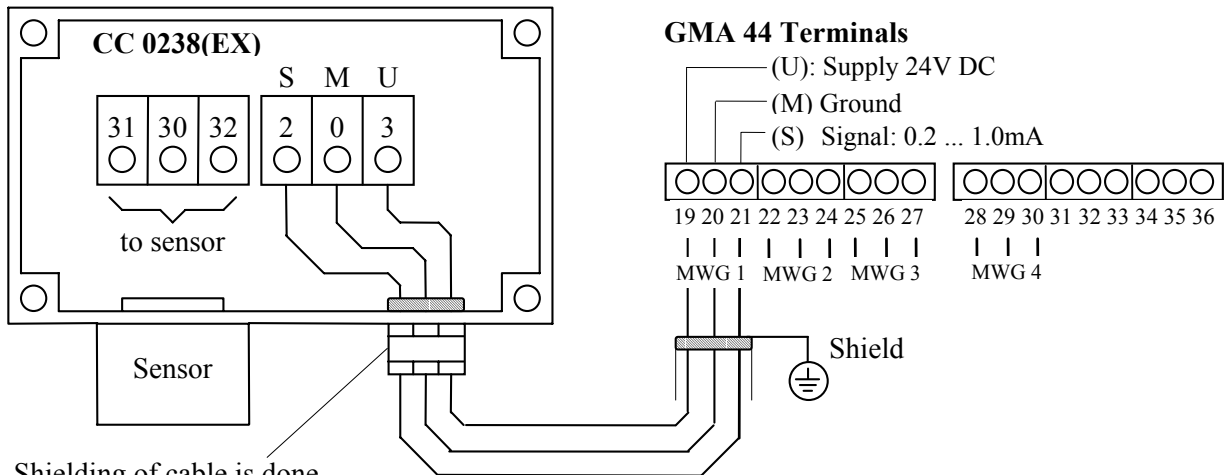

Shielding of cable is done over the EMC cable screwing

MWG = Transmitter

Transmitter CS21 and CI21

These sensors are designed as 3-wire transmitters.

0.2 – 1mA

The supply voltage and the 0.2 - 1mA output signal use the same ground line. Cable type: 18 gauge 3 strand shielded (up to 200m)

For connection of transmitters 2 to 4 repeat the steps for transmitter 1 (see picture below).

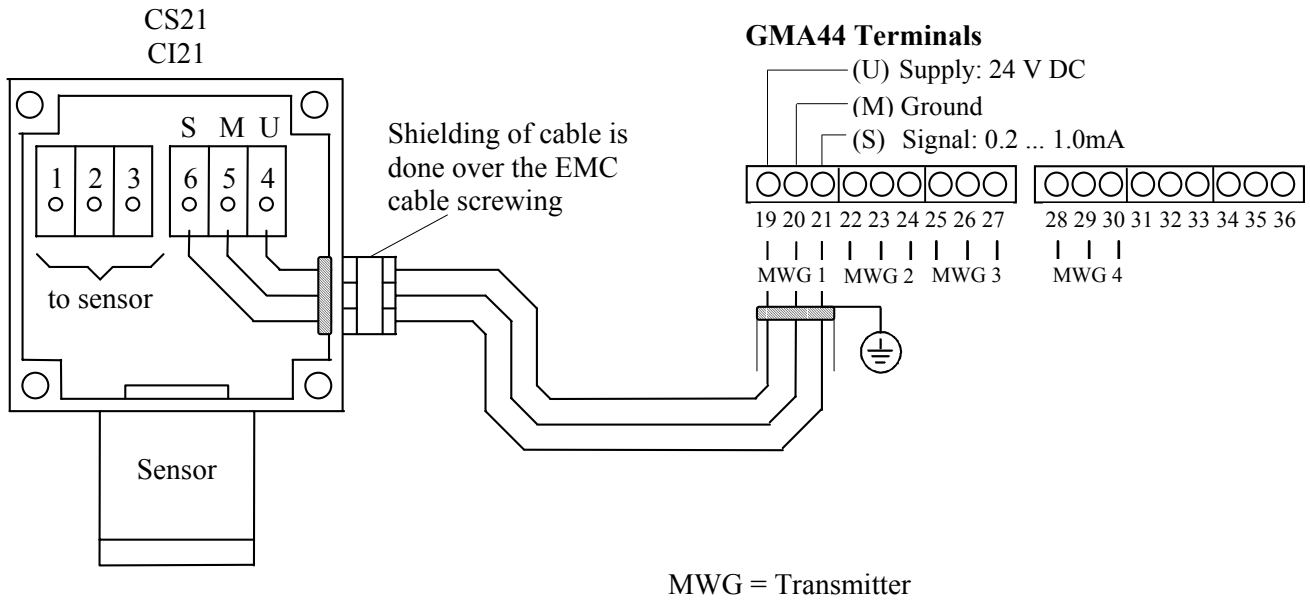

4 – 20 mA output signal

The supply voltage and the 4 – 20 mA output signal use the same ground line.

For connection of transmitters 2 to 4 repeat the steps for transmitter 1 (see picture below).

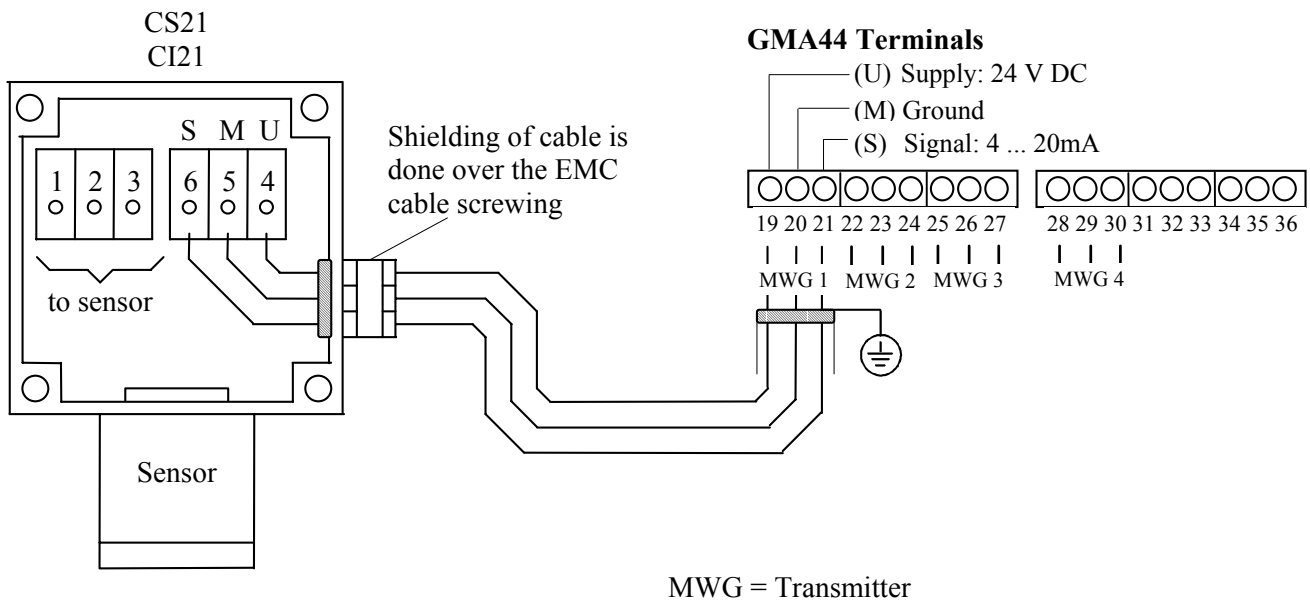

Transmitter EC24 (models MWG 2412, 2414, 2411 and 2413)

4 – 20 mA output signal

The EC models MWG 2412 and MWG 2414 are designed as 2-wire transmitters. The 4 - 20mA output signal is provided via the supply line.

For connection of transmitters 2 to 4 repeat the steps for transmitter 1 (see picture below).

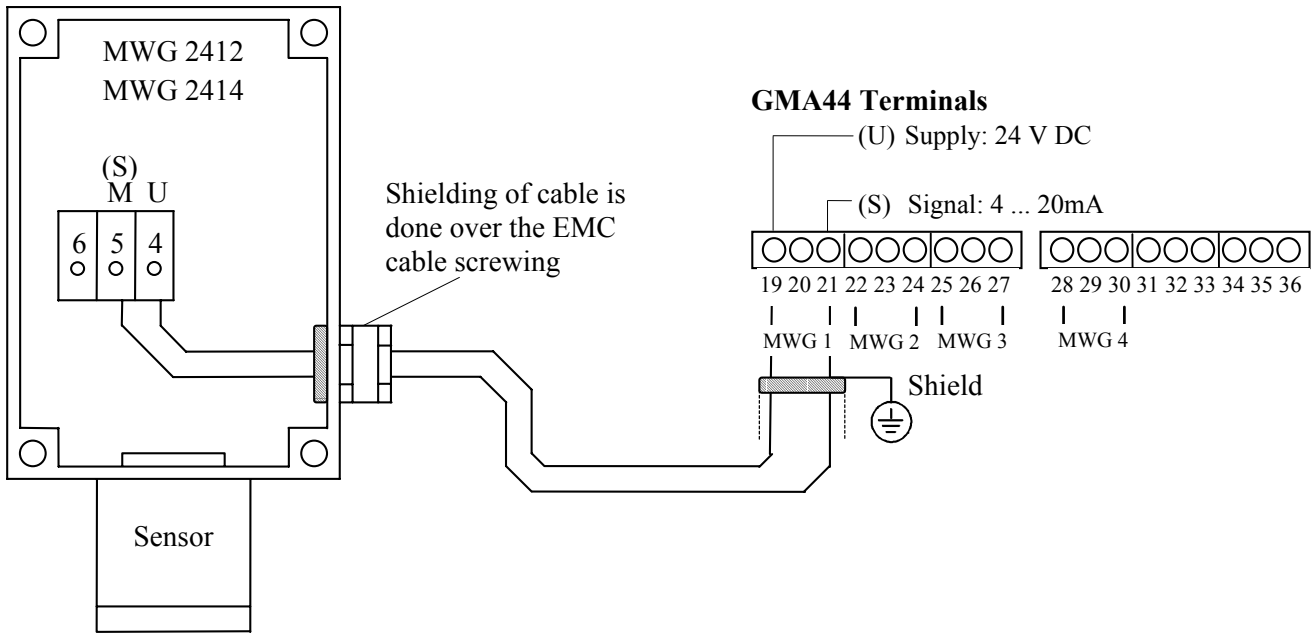

0.2 – 1 mA output signal

The EC models MWG 2411 and MWG 2413 are designed as 3-wire transmitters. The supply voltage and the 0.2 - 1mA output signal use the same ground line.

For connection of transmitters 2 to 4 repeat the steps for transmitter 1 (see picture below).

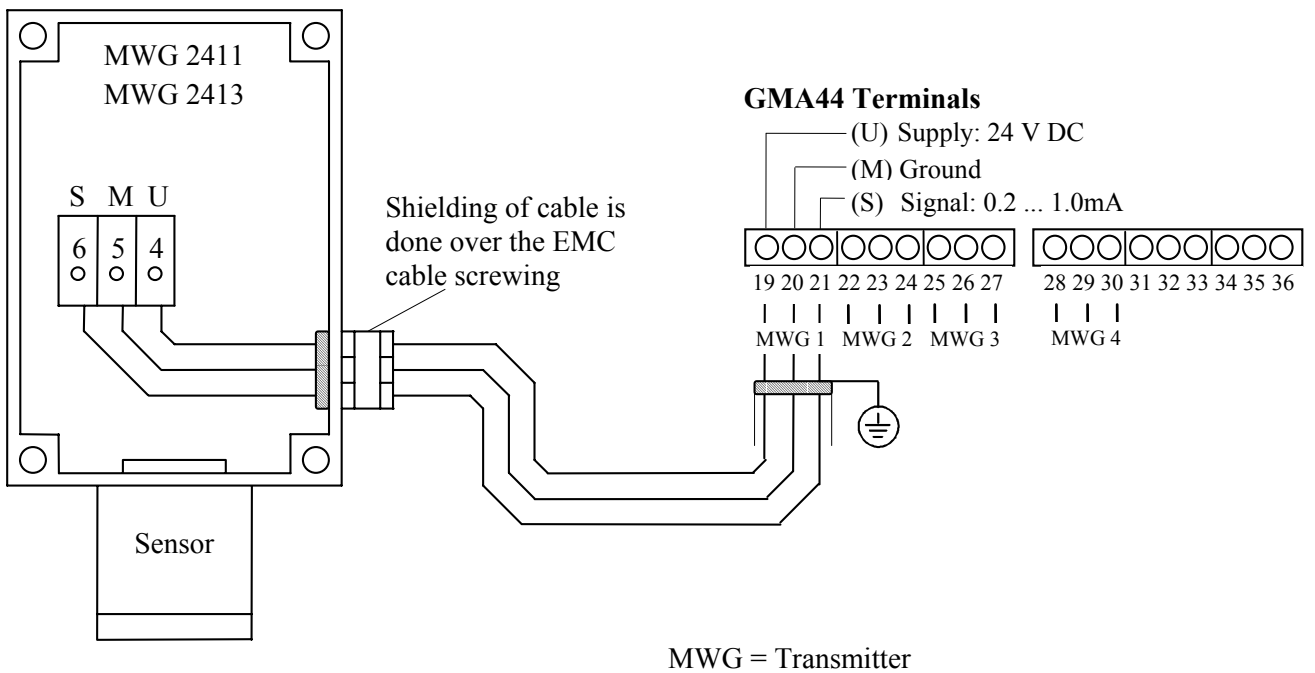

Transmitter CC24 EX (models MWG 2431 and 2432),

Transmitter CS24 EX (models MWG 2471 and 2472)

0.2 – 1 mA output signal

The CC sensor MWG 2431, the CS sensor MWG 2471 are designed as 3-wire transmitters. The supply voltage and the 0.2 - 1mA output signal use the same ground line.

For connection of transmitters 2 to 4 repeat the steps for transmitter 1 (see picture below).

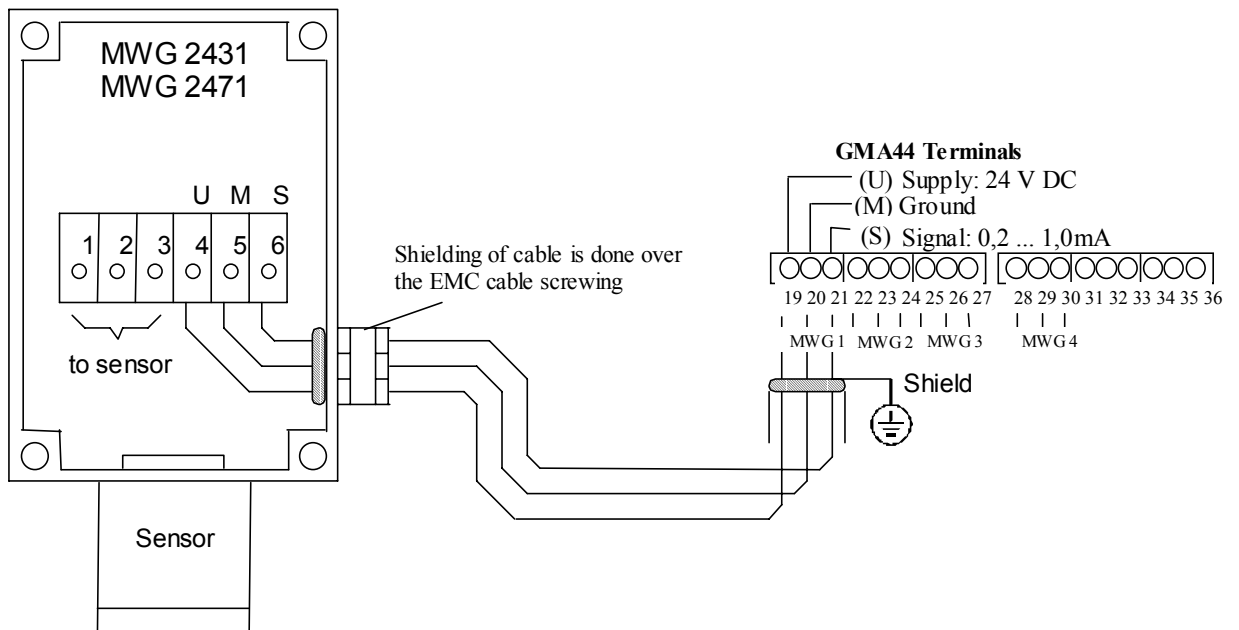

MWG = Transmitter

4 – 20 mA output signal

The CC sensor MWG 2432, the CS sensor MWG 2472 are designed as 3-wire transmitters. The supply voltage and the 4 - 20mA output signal use the same ground line.

For connection of transmitters 2 to 4 repeat the steps for transmitter 1 (see picture below).

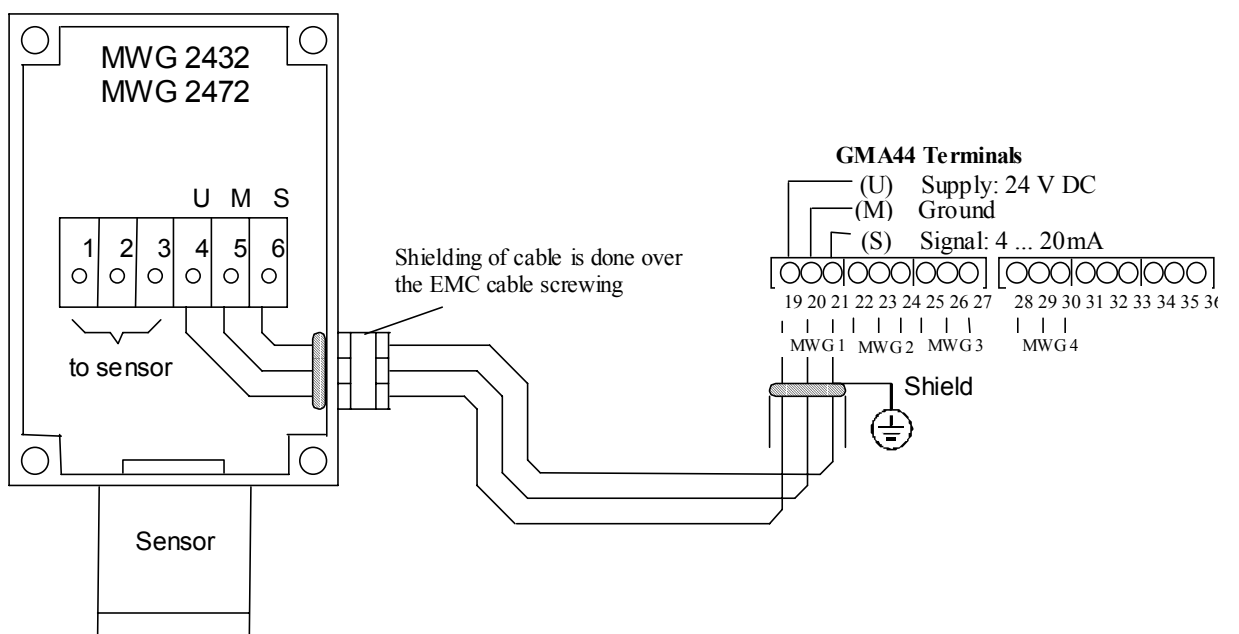

MWG = Transmitter

Transmitter IR 24 (Type MWG 2491 and type 2492)

0.2 – 1 mA output signal

The IR sensor MWG 2491 is designed as 3-wire transmitters. The supply voltage and the 0.2 - 1mA output signal use the same ground line.

For connection of transmitters 2 to 4 repeat the steps for transmitter 1 (see picture below).

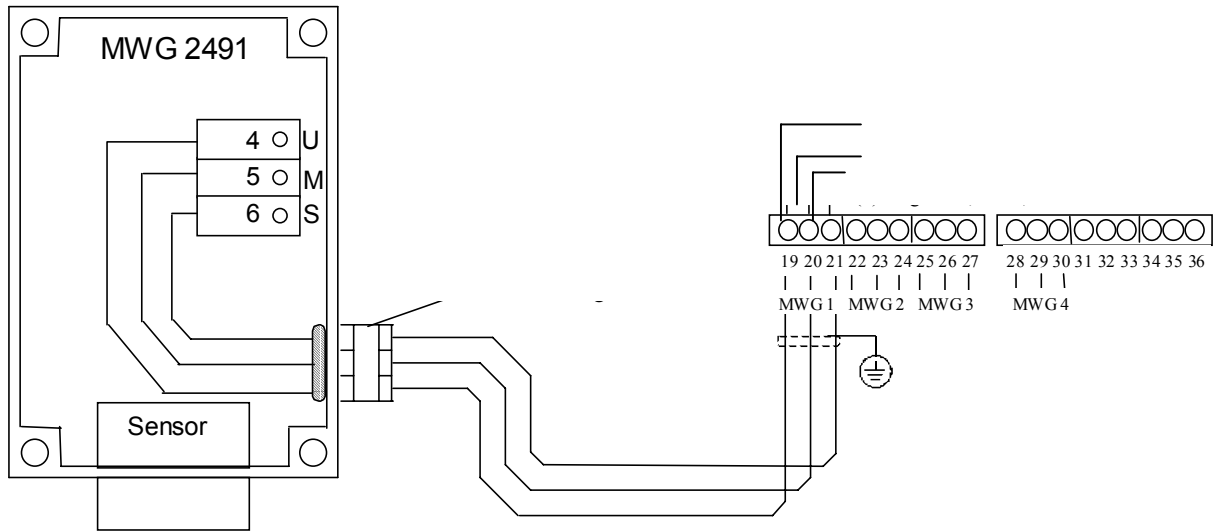

MWG = Transmitter

4 – 20 mA output signal

The IR sensor MWG 2492 is designed as 3-wire transmitters. The supply voltage and the 4 - 20mA output signal use the same ground line.

For connection of transmitters 2 to 4 repeat the steps for transmitter 1 (see picture below).

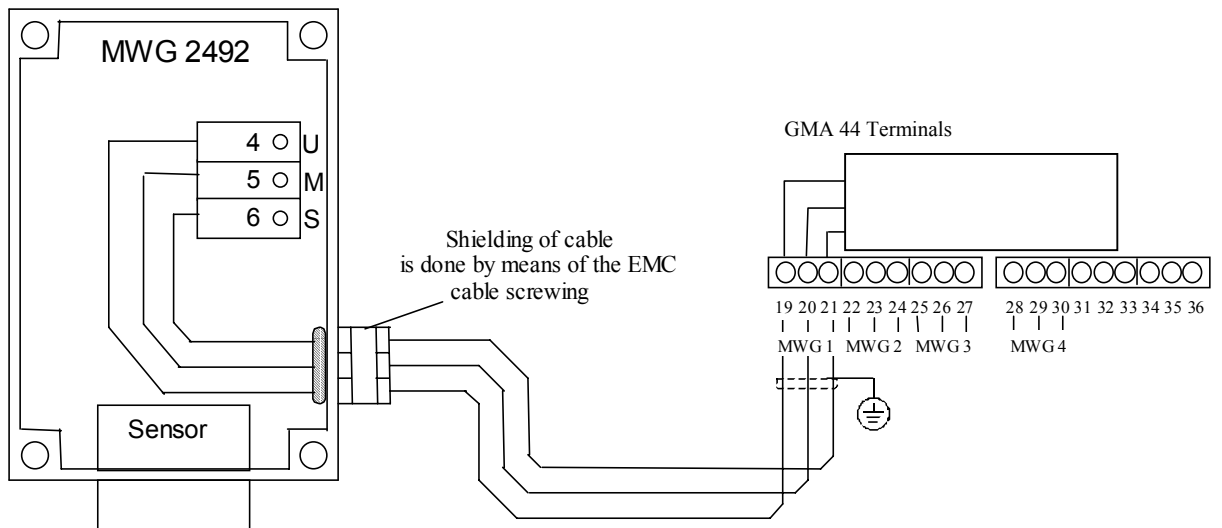

MWG = Transmitter

Transmitter EC25 (models MWG 502, 2504, 2501 and 2503) without Ex-barrier

4 – 20 mA output signal

The EC sensors MWG 2502 and 2504 are designed as 2-wire transmitters. The 4 - 20mA output signal is provided via the supply line.

For connection of transmitters 2 to 4 repeat the steps for transmitter 1 (see picture below).

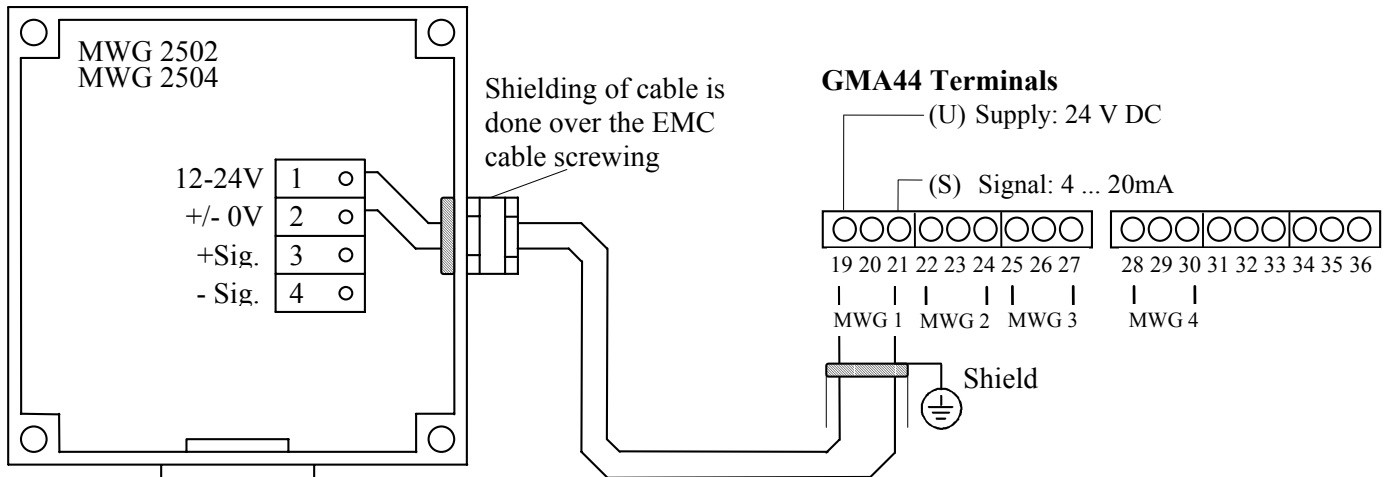

MWG = Transmitter

0.2 – 1mA output signal

The EC sensors MWG 2501 and MWG 2503 are designed as 3-wire transmitters. The supply voltage and the 0.2 - 1mA output signal use the same ground line.

For connection of transmitters 2 to 4 repeat the steps for transmitter 1 (see picture below).

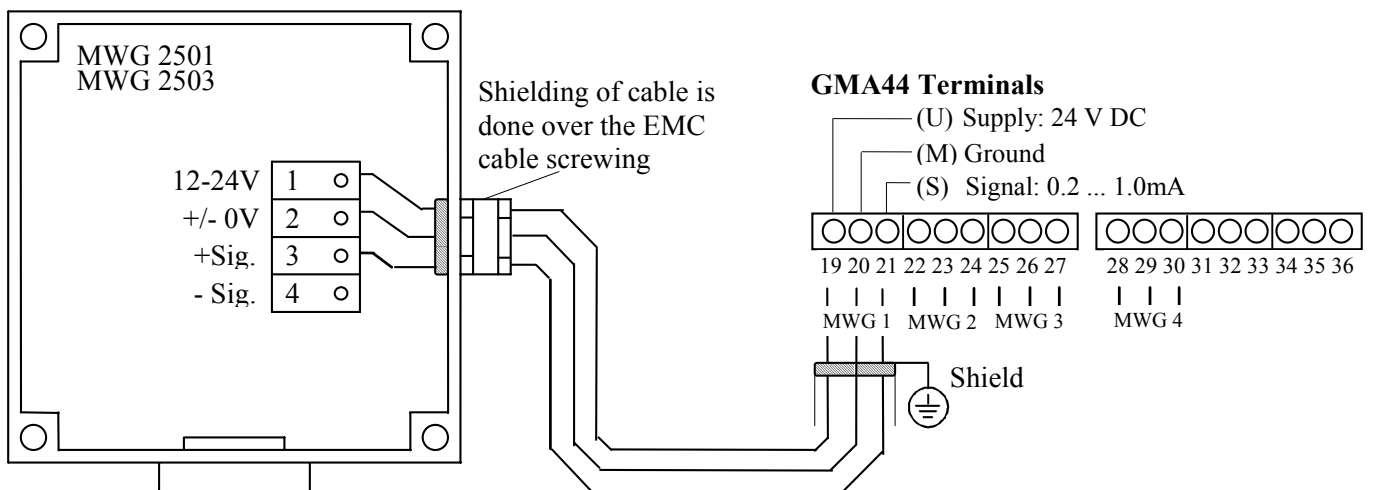

MWG = Transmitter

Transmitter EC25 EX (model MWG 2501) with Ex-barrier

0.2 – 1 mA output signal

The EC sensor MWG 2501 is designed as 4-wire transmitter. Supply and signal lines are separated. The transmitter is considered as 4-pole. For reasons of explosion protection, Ex-barriers are linked between transmitter and GMA44 both in the supply lines and in the signal lines.

For connection of transmitters 2 to 4 repeat the steps for transmitter 1 (see picture below).

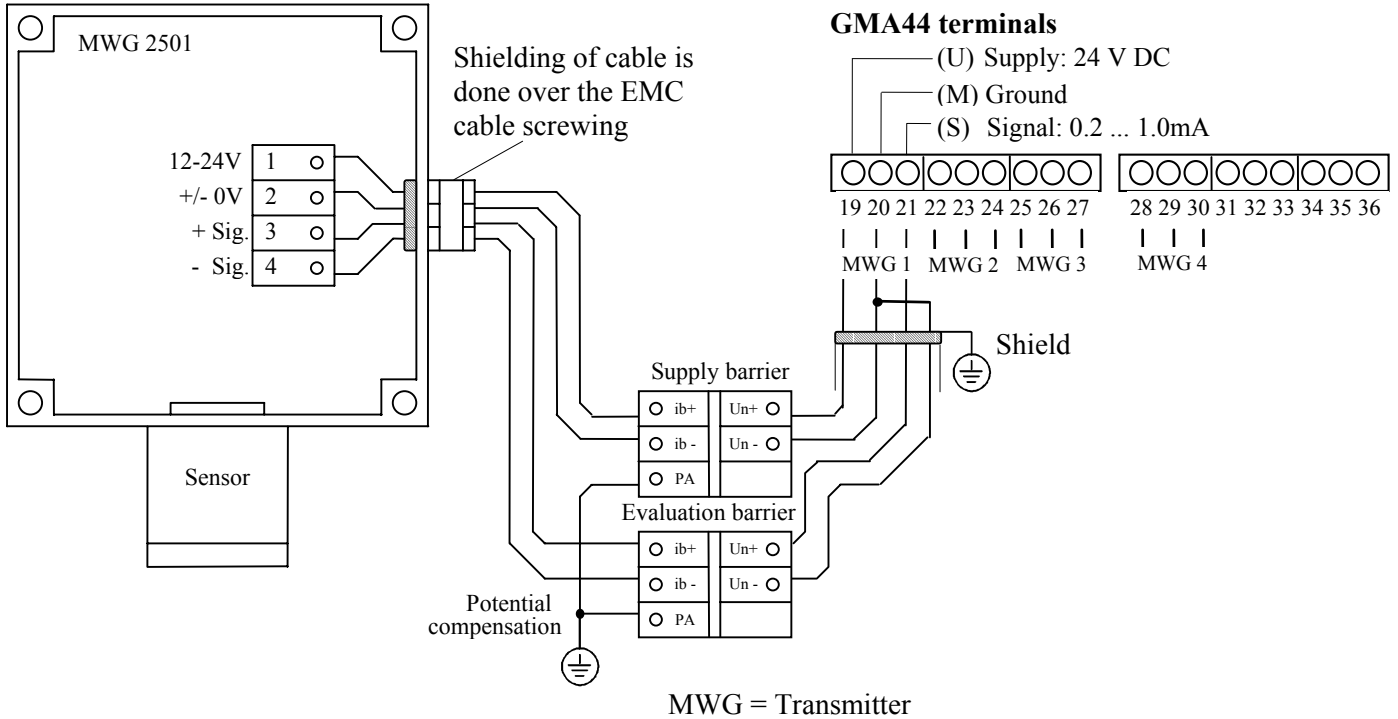

Worldwide Supplier of Gas Detection Solutions



GfG Instrumentation
1194 Oak Valley Drive
Phone: 734-769-0573
Fax: 734-769-1888
E-Mail: info@gfg-inc.com
Internet: www.gfg-inc.com

185-000.14.doc Edition June 1, 2002 Software Version 2.02
We reserve the right of modification