



# DLAF930SD

## USER'S MANUAL



# ENVIRONMENT METER WITH DATALOGGING SD CARD

*Please read this manual carefully and thoroughly before using this product.*

# TABLE OF CONTENTS

<b>Introduction</b> .....	<b>3</b>
<b>Key Features</b> .....	<b>4</b>
<b>Operating Instructions</b> .....	<b>4 – 12</b>
<b>What's in the case</b> .....	<b>4 – 5</b>
<b>Setup</b> .....	<b>6 – 8</b>
<b>Normal Operation</b> .....	<b>8 – 10</b>
<b>Holding and Storing Measurements</b> .....	<b>10</b>
<b>Automatic vs. Manual Datalogging</b> .....	<b>10 – 11</b>
<b>Transferring Data from the SD Card     to a Computer</b> .....	<b>11 – 12</b>
<b>Specifications</b> .....	<b>12 – 13</b>
<b>Maintenance &amp; Troubleshooting Tips</b> .....	<b>13</b>
<b>Optional Accessories</b> .....	<b>14</b>
<b>Warranty Information</b> .....	<b>14</b>
<b>Return for Repair Policy</b> .....	<b>14</b>

---

## INTRODUCTION

Thank you for purchasing General Tools & Instruments' DLAF930SD Environment Meter with Datalogging SD Card. Please read this user's manual carefully and thoroughly before using the instrument.

The DLAF930SD is a general-purpose handheld instrument that can make five kinds of measurements:

- Air (wind) speed and temperature (simultaneously)
- Air temperature and humidity (simultaneously)
- Light level
- Surface temperature, as measured by an optional Type K or Type J thermocouple
- Sound level (using an optional sound level probe and plug adapter)

The meter comes with a multi-function probe that is used to make the first three types of measurement. Measurements of surface temperature and sound level are made using optional accessories. Air speeds can be displayed in m/s (meters/second), fpm (feet per minute), km/h (kilometers/hr), knots (nautical miles per hour), or mph (miles per hour). Light levels can be displayed in lux or ft-cd (foot-candles). Temperatures can be displayed in °F (Fahrenheit) or °C (Celsius) units.

Several features and capabilities enhance the meter's versatility. Among them are automatic temperature compensation for measurements made by the anemometer or a Type K or Type J thermocouples, the ability to hold readings and display maximum and minimum readings, and an automatic power off function that extends battery life.

Because it is microprocessor-based, the DLAF930SD can make full use of the portability, reliability and large storage capacities that SD memory cards offer. Measurements can be made automatically at any sampling rate between one second and one hour. After time-stamping and storing the measurements on an SD card plugged into the instrument (a process called datalogging), the user can remove the card and plug it into a laptop or desktop computer either directly or via a USB card reader. The data logs are stored on the card as files with the .xls extension, which can be opened by Microsoft's Excel application.

The DLAF930SD has a backlit 2-1/2 in. diagonal display and is powered by six "AA" Alkaline batteries or an optional 9-VDC AC adapter.

---

## KEY FEATURES

- Multi-function probe measures air speed and temperature, air temperature and humidity, and light level. Optional accessories measure surface temperature and sound level
- Big (2.5 in. diagonal) front-panel green backlit LCD is easy to read
- Displays maximum and minimum readings and holds any reading
- Automatically logs measurements at sampling time settable from one second to one hour
- Also supports manual datalogging and changing of SD card storage location
- Outputs Excel-compatible data logs
- Accepts SD memory cards of up to 16 GB capacity
- Auto power off function
- Powered by six “AA” batteries or optional 9V AC/DC adapter

---

## OPERATING INSTRUCTIONS

### ***WHAT’S IN THE CASE***

The DLAF930SD comes fully assembled in a carrying case along with a multi-function (temperature, humidity, air speed, light level) probe, a 2 GB SD memory card and this user’s manual.

Optional accessories available from General Tools & Instruments include:

- A sound level probe and plug adapter
- Types K and J thermocouples
- A 9VDC adapter for a 110V or 220V power supply

*See the Optional Accessories section of this manual for more details.*

**Figure 1** shows all of the controls and indicators on the front, right side, back, top and bottom of the DLAF930SD. It also shows (at right) the main components of the included multi-function probe. Familiarize yourself with the positions and functions of these controls, indicators and connectors before moving on to the setup procedure.

# 1. The DLAF930SD's controls and indicators and other physical features

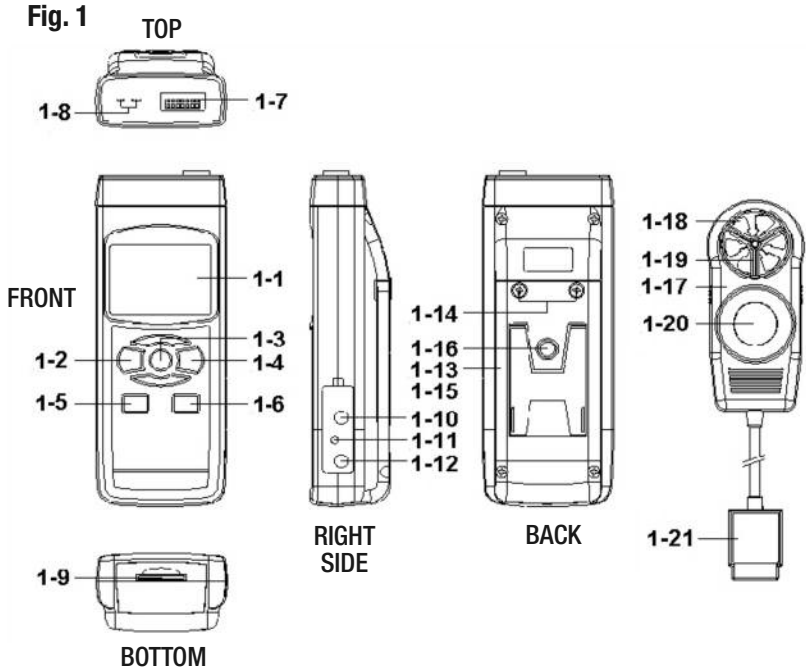

- |   |                                       |
|---|---------------------------------------|
| 1-1 Liquid-crystal display  | 1-11 RESET button                     |
| 1-2 POWER/ESC button  | 1-12 Socket for 9VDC AC adapter       |
| 1-3 FUNC./HOLD/NEXT button  | 1-13 Battery compartment cover        |
| 1-4 REC/ENTER button  | 1-14 Battery compartment cover screws |
| 1-5 SET ▼ button  | 1-15 Kickstand                        |
| 1-6 LOGGER ▲ button   | 1-16 Tripod attachment nut            |
| 1-7 Socket for multi-function probe or optional sound level probe | 1-17 Multi-function probe head        |
| 1-8 Socket for Type K or J thermocouple thermometer               | 1-18 Anemometer                       |
| 1-9 SD card socket  | 1-19 Temperature-humidity sensor      |
| 1-10 RS-232 output jack   | 1-20 Light sensor                     |
|   | 1-21 Multi-function probe plug        |

## SETUP

**1. Choose the power source.** Before using the DLAF930SD, make sure it is powered by fresh batteries or an optional 9VDC AC adapter plugged into the bottom jack on its right side (callout 1-12).

To remove the battery compartment cover (callout 1-13), remove the two screws holding it in place (callout 1-14). Then install six “AA” batteries in the correct orientation, using the polarity marks on the inside of the compartment as a guide. Replace the cover by replacing the two screws.

**2. Install an SD card.** To prepare for setup, also install the supplied 2 GB SD memory card or another card with a capacity from 1 GB to 16 GB in the socket on the bottom of the meter (callout 1-9). When installing the card, make sure its gold contacts are facing front and push the card into the socket until you hear a click. To remove the card, push it in until you hear a click and the card pops out.

Now power on the instrument by pressing the POWER/ESC button (callout 1-2) to generate a short beep. (To power off the DLAF930SD, press the POWER/ESC button and hold it until the instrument responds with a long beep.)

When the meter powers on, a series of transient startup screens will briefly appear. Once the display has stabilized, perform the following eight setup steps in the order presented.

**3. Set the date and time.** Press the SET ▼ button (callout 1-5) and hold it for at least five seconds, until the word “dAtE” appears in the center of the display, along with the flashing value “00.00.00” at the lower left, above “yy.mm.dd”.

Set the current year by pressing the SET ▼ or LOGGER ▲ button repeatedly until the correct value appears above “yy”. Quickly (within three seconds), press the REC/ENTER button to store the setting. The next screen that appears will have the value above “mm” flashing. Use the SET ▼ or LOGGER ▲ button to navigate to the current month and press the REC/ENTER button to store the setting. When the next screen flashes the value above “dd”, again use the SET ▼ or LOGGER ▲ button to navigate to the current day and press the REC/ENTER button to store the setting.

(If you press buttons too slowly in setup mode, the screen will revert to the normal display. To return to the setup sequence, press and hold the SET ▼ button again. To move ahead to the next field in the sequence or to the next parameter, press the FUNC./HOLD/NEXT button.)

Once you have set the date, the display will prompt you to set the hour, minute and second of the current time. Again use the SET ▼ or LOGGER ▲ buttons to navigate to the correct values, and the REC/ENTER button to store the settings.

- 4. Choose a decimal point or comma** to represent the decimal division between integers and fractions (for example, American-style 20.88 vs. European-style 20,88). Once you have set the date and time, the display will show the word “bASIC” above the phrase “dEC”. Press the SET ▼ button to make “bASIC” (American style) or “Euro” appear in the upper display, as desired. Press the REC/ENTER button to store the selection as the default.
- 5. Enable or disable auto power off.** Once the format of decimal point divisions has been set and stored, the display will show the word “yES” over the term “PoFF”. Press the SET ▼ button until the desired automatic power off management scheme (“yES” for enable; “no” for disable) is displayed. Press the REC/ENTER button to store the selection. If enabled, the power off function shuts off the DLAF930SD after a period of inactivity of ten minutes.
- 6. Enable or disable the beeper.** Once the auto power off function has been enabled or disabled, the display will show the word “yES” over the word “bEEP”. Press the SET ▼ button until the desired setting (“yES” or “no”) is displayed, and then press the REC/ENTER button to store the selection as the default.
- 7. Select the thermocouple type.** Once the beeper has been enabled or disabled, the lower part of the display will show the term “tYPE”. Press the SET ▼ or LOGGER ▲ button until your thermocouple’s type (K or J) appears on the display. Then press the REC/ENTER button to store the selection.
- 8. Select the temperature unit.** Once the thermocouple type has been selected and stored, the lower part of the display will show the term “t-CF”. Press the SET ▼ or LOGGER ▲ button until the unit you prefer (“F” for Fahrenheit or “C” for Celsius”) is displayed. Then press the REC/ENTER button to store the selection as the default.
- 9. Set the datalogging sampling time.** Once the default temperature unit has been selected and stored, the display will show a value above the letters “SP-t”. Press the SET ▼ or LOGGER ▲ button to decrease or increase the value until the desired sampling time appears above “SP-t”. The options are 0, 1, 2, 5, 10, 30, 60, 120, 300, 600, 1800 and 3600 seconds (0 seconds to 1 hour).
- 10. Format the SD card.** Once the sampling time has been set and stored, the term “Sd-F” will appear in the lower half of the display. Press the REC/ENTER button.

Pressing the REC/ENTER button causes the word “no” or “yES” to appear over the term “Sd-F”. Press the ▼ button to make a selection. Choose “yES” whenever a new SD card is being used, or when a used card is being repurposed (from use with another SD card instrument or a camera, for example) and all data on it is to be erased. Choose “no” to preserve any data on a card previously used with this instrument.

If you choose “yES”, after you press the REC/ENTER button the instrument will prompt you to confirm that decision by displaying the term “Ent” below “yES” and sounding three beeps. To confirm that you want to begin the erasure/formatting procedure, press the REC/ENTER button. “Ent” will then flash several times and the instrument will sound another three beeps to confirm that the SD card has been erased and formatted.

Once the SD card has been set up, the display will then either return to the first of the eight steps in the setup sequence—setting the current date and time—or show the term “ESC”. If “ESC” appears, press the POWER/ESC button to exit the setup procedure and enter normal operating mode.

## ***NORMAL OPERATION***

**1. To prepare to make measurements**, power on the DLAF930SD and make sure an SD card is firmly seated in the socket on the bottom of the meter.

The meter can make and display five kinds of measurements:

- Air speed and temperature (simultaneously)
- Air temperature and humidity (simultaneously)
- Surface temperature, as measured by an optional Type K or Type J thermocouple
- Light level
- Sound level (using an optional sound level probe and plug adapter)

**2. To select the measurement mode**, use the FUNC./HOLD/NEXT button. Pressing the button repeatedly cycles through the four main modes (sound level is measured in a separate operating mode, as explained below). When the FUNC./HOLD/NEXT button is released, the selected mode becomes the default until the button is pressed again.

By default, the DLAF930SD uses Celsius units for temperature measurements. If you wish to make Fahrenheit units the default, press the SET ▼ button to enter the setup procedure and perform Step 8.

**3. To measure air speed and temperature simultaneously**, seat the multi-function probe plug (callout 1-21 of Fig. 1) in its socket (callout 1-7) on the top of the meter. Then press the FUNC./HOLD/NEXT button until the display shows the term “An”. Holding the probe by its handle, turn its head so the anemometer vanes face the flow of air. The upper part of the display will show the air speed while the lower part will show the temperature (as “°F” or “°C”).

**To change the units of air speed**, use the REC/ENTER button (which has the word “Unit” stenciled below it). Repeated presses of the button cycle through the five options for air speed units: m/s (meters/second), fpm (feet per minute), km/h (kilometers/hr), knots (nautical miles per hour), and mph (miles per hour). Release the REC/ENTER button when the unit you wish to use appears, making it the default until changed.



**4. To measure air temperature and humidity simultaneously,** seat the multi-function probe plug in its socket on the top of the meter. Then press the FUNC./HOLD/NEXT button until the display shows the term “rH”. Holding the probe by its handle, expose its head to a representative volume of air whose temperature and humidity you wish to measure. The upper part of the display will show the measured relative humidity value (as “%RH”) while the lower part will show the temperature (as “°F” or “°C”).

**5. To measure surface temperature with a thermocouple,** make sure the multi-function probe is not in its socket. Plug an optional Type K or Type J thermocouple into its dedicated socket (callout 1-8 of Fig. 1). Then press the FUNC./HOLD/NEXT button until the display shows the term “tP”.

Touch the wire end of the thermocouple to the surface whose temperature you wish to measure. The display will show its temperature (as “°F” or “°C”).

By default, the DLAF930SD is configured for a Type K thermocouple. To use a Type J thermocouple, press the SET ▼ button to enter the setup procedure and perform Step 7.

**6. To measure the ambient light level or the intensity of a light source,** seat the multi-function probe plug in its socket on the top of the meter. Then press the FUNC./HOLD/NEXT button until the display shows the term “LigHt”. Completely cover the light sensor (callout 1-20 of Fig. 1) with your hand. If the display shows a value other than zero, press the LOGGER ▲ button and hold it for at least three seconds until you hear a beep and the display shows a zero reading. Then uncover the light sensor.

Holding the probe by its handle, either expose its head to ambient light or point it at the light source whose intensity you wish to measure. The display will show the measured light intensity in units of lux or foot-candles (ft-cd).

To change the unit of light intensity, use the REC/ENTER button. Repeated presses of the button toggle through the two options for light intensity units: lux or ft-cd. Release the REC/ENTER when the unit you wish to use appears, making it the default until changed.

**7. To measure sound intensity** using an optional sound level probe and plug adapter, first power off the DLAF930SD. Then plug one end of the plug adapter into the probe and the other end into the socket at the top of the meter (callout 1-7 of Fig. 1). Power on both the sound level probe and the DLAF930SD. The meter’s display will briefly show the word “Sound” and then switch to a normal measurement display. Point the head of the sound level probe at the sound source whose volume you wish to measure. The display will show the sound level, in units of dB.

Whenever the meter is in measurement mode, you can turn off the backlight (which is on by default) by briefly pressing (but not holding) the POWER/ESC button. To reactivate the backlight, briefly press the button again.

Whenever the instrument is in measurement mode, you also can check the current date and time by briefly pressing the SET ▼ button (which has the words “Time check” stenciled below it). Doing so causes both values to appear briefly at the lower left of the display.

### ***HOLDING AND STORING MEASUREMENTS***

- 8. To hold a measured value**, press the FUNC./HOLD/NEXT button during the measurement. Doing so will cause the word “HOLD” to appear at the top of the display. Pressing the FUNC./HOLD/NEXT button again releases the hold.
- 9. To record and recall readings**, press the REC/ENTER button while making measurements. This will make the term “REC” appear at the top of the display. Pressing the REC/ENTER button again, briefly, will make the term “MAX” appear to the right of “REC” and switch the display to the maximum value stored in memory during the last recording session. Pressing the REC/ENTER button again, briefly, will make the term “MIN” appear to the right of “REC” and switch the display to the minimum value stored during the last session.
- 10. To exit recording mode**, press the REC/ENTER button and hold it for at least three seconds, until the term “REC” disappears from the top line of the display. The display will then revert to showing the current reading.

### ***AUTOMATIC VS. MANUAL DATALOGGING***

The DLAF930SD can automatically log data at a user-selected sampling period from 1 second to 3,600 seconds (one hour). To view the sampling time that the instrument has been set up to use, press the LOGGER ▲ button (which has the words “Sampling check” stenciled below it) once. To change the sampling time, perform Step 9 of the setup procedure.

- 11. To start automatic datalogging**, press the REC/ENTER button once. The top line of the display will then show the term “REC”. Pressing the LOGGER ▲ button at this point will make REC flash and add the flashing term “LOGGER” at the top right of the display. This indicates that the instrument is currently storing measured values and their time stamps in memory.
- 12. To pause automatic datalogging**, press the LOGGER ▲ button once; this action makes the flashing term “LOGGER” disappear from the top right of the display and changes the term “REC” from flashing to constant. Pressing the LOGGER ▲ button again resumes automatic datalogging.
- 13. To end automatic datalogging**, press the REC/ENTER button and hold it for at least two seconds. This action causes the “REC” message to disappear.

**14. To log data manually**, set the sampling time to zero using the procedure detailed earlier. Then press the REC/ENTER button once. The display will show the term “REC” on the top line, a value in the middle, and below it the letter “P” on the left and a number from 1 to 99 on the same line to the right. The number indicates the position on the SD card that will be used to store manually logged data.

Now press the LOGGER ▲ button. This will cause the beeper to sound and the term “LOGGER” to briefly appear at the upper right of the display. As in automatic datalogging mode, in this mode the instrument is storing measurements and their time stamps on the SD card.

In manual datalogging mode, however, measurements are being stored continuously (with a sampling time of zero), and their locations on the card can be changed.

**15. To change the storage location of manually logged data**, press the SET ▼ button once; this causes the “P” to disappear from the left side of the display and the value on its line to begin flashing. Once the flashing begins, you can use the SET ▼ and LOGGER ▲ buttons to change the flashing value to any number between 1 and 99. Once you have chosen the storage location, press the REC/ENTER button to save the setting. This causes the value to stop flashing and the “P” to return.

**16. To end manual datalogging**, press the REC/ENTER button and hold it for at least three seconds. This action causes the “REC” message to disappear from the top line of the display.

## TRANSFERRING DATA FROM THE SD CARD TO A COMPUTER

After automatic or manual datalogging of measurements, remove the SD card from the meter and plug it into your computer either directly (if it has an SD card slot) or through an SD card reader.

Because the files containing time-stamped data logs have the file extension .xls, they open in Microsoft’s Excel application. Figures 2 and 3 show two kinds of Excel presentations: a data-only screen and a graphics-only screen.

	A	B	C	D	E	F	G	H
1	Place	Date	Time	Value	Unit	Value	Unit	
2	1	2009/6/8	15:12:16	0.8	m/s	28.8	AMTemp C	
3	2	2009/6/8	15:12:17	2.2	m/s	28.8	AMTemp C	
4	3	2009/6/8	15:12:18	2.1	m/s	28.8	AMTemp C	
5	4	2009/6/8	15:12:19	2.9	m/s	28.9	AMTemp C	
6	5	2009/6/8	15:12:20	2.9	m/s	28.8	AMTemp C	
7	6	2009/6/8	15:12:21	2.7	m/s	28.8	AMTemp C	
8	7	2009/6/8	15:12:22	3.6	m/s	28.8	AMTemp C	
9	8	2009/6/8	15:12:23	2.9	m/s	28.8	AMTemp C	
10	9	2009/6/8	15:12:24	2.9	m/s	28.8	AMTemp C	
11	10	2009/6/8	15:12:25	2.9	m/s	28.8	AMTemp C	
12	11	2009/6/8	15:12:26	2.9	m/s	28.9	AMTemp C	
13	12	2009/6/8	15:12:27	3	m/s	28.8	AMTemp C	
14	13	2009/6/8	15:12:28	3.1	m/s	28.8	AMTemp C	
15	14	2009/6/8	15:12:29	3.1	m/s	28.7	AMTemp C	
16	15	2009/6/8	15:12:30	5.9	m/s	29.1	AMTemp C	
17	16	2009/6/8	15:12:31	4.2	m/s	29	AMTemp C	
18	17	2009/6/8	15:12:32	3.2	m/s	28.9	AMTemp C	
19	18	2009/6/8	15:12:33	2.6	m/s	28.6	AMTemp C	
20	19	2009/6/8	15:12:34	3.1	m/s	28.7	AMTemp C	
21	20	2009/6/8	15:12:35	3	m/s	28.7	AMTemp C	
22	21	2009/6/8	15:12:36	3	m/s	28.9	AMTemp C	
23	22	2009/6/8	15:12:37	3.1	m/s	28.9	AMTemp C	
24	23	2009/6/8	15:12:38	2.8	m/s	28.9	AMTemp C	

Fig. 2. Typical Excel data-only screen

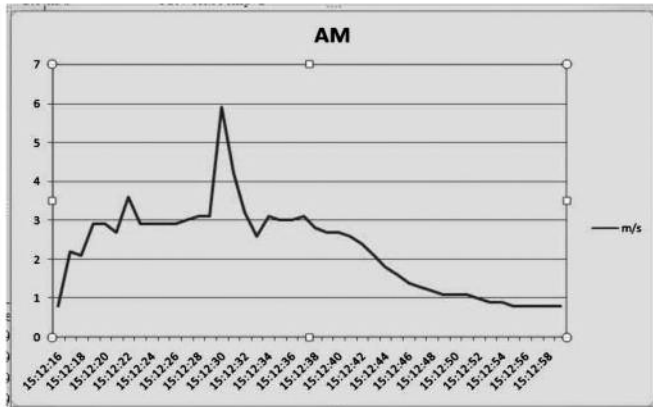

**Fig. 3. Typical Excel graphics-only screen**

## SPECIFICATIONS

Embedded microcontroller	Custom one-chip LSI device
Display type	Liquid-crystal with green backlight
Display size	2.05 x 1.5 in. (52 x 38mm)
Parameters measured	Air temperature, relative humidity (R.H.), air speed, light level
Measurement range	For temperature, 32 to 122°F (0 to 50°C); for R.H., 0 to 95%; for air speed: 0.4 to 25 m/sec, 1.4 to 90 km/hr, 0.9 to 55.9 mph, 0.8 to 48.6 knots, 80 to 4930 ft/min; for light level: 0 to 20,000 lux, 0 to 1860 ft-cd
Measurement accuracy	For temperature: $\pm 1.5^{\circ}\text{F}$ ( $\pm 0.8^{\circ}\text{C}$ ); for humidity: $\pm$ (3% of reading + 1%) for R.H. values $\geq 70\%$ ; $\pm 3\%$ of reading for R.H. values $<70\%$ ; for air speed: $\pm$ (2% + 0.2 m/sec), $\pm$ (2% + 0.8 km/hr), $\pm$ (2% + 0.4 mph), $\pm$ (2% + 0.4 knots), $\pm$ (2% + 40 ft/min); for light level, $\pm$ (5% of reading $\pm$ 8 digits)
Measurement resolution	For temperature, 0.1°F or °C; for humidity, 0.1% of reading; for air speed: 0.1 ms, 0.1 km/hr, 0.1 mph, 0.1 knots, 1.0 ft/min; for light level: 1 lux, 0.1 ft-cd
Sampling time options	0, 1, 2, 5, 10, 30, 60, 120, 300, 600, 1800 or 3600 seconds (0 seconds to 1 hour)

Settable parameters	Date, time, auto power off, beep sound, sampling time, decimal point or comma decimal division, temperature unit, air speed unit, light level unit, optional thermocouple type (K or J)
Storable/recallable readings	Maximum, minimum
SD card capacity	1 GB to 16 GB
Operating temperature	32° to 122°F (0° to 50°C)
Operating relative humidity	0 to 85%
Power source	6 Alkaline “AA” batteries or optional 9-VDC AC adapter
Power consumption	3.5 mADC (normal operation, with backlight off and SD card not saving data); 28 mADC with backlight on and card saving data; 40 mADC with backlight on and card saving data
Dimensions of meter	5.31 x 2.36 x 1.30 in. (135 x 60 x 33mm)
Weight of meter	1.13 lb. (515g) Dimensions of probe 4.13 x 1.81 x 1.14 in. (105 x 46 x 29mm)

## MAINTENANCE & TROUBLESHOOTING TIPS

Keep the multi-function probe clean. Store it in the carrying case when you are not using the meter.

When the icon  appears in the left corner of the display, it's time to replace the six “AA” batteries that power the instrument (although measurements will remain valid for several hours after the low-battery indicator first appears). Replacing the batteries requires removing the two screws that hold the battery compartment cover in place, as explained earlier. After inserting fresh batteries in the correct orientation, tighten the screws to secure the cover.

If the meter “freezes” (like a computer) and buttons become unresponsive, try resetting the instrument by pushing the RESET button on its right side (callout 1-11 of Fig. 1) with the end of a paper clip.

Remove the batteries when storing the meter for an extended period of time.

Do not drop or disassemble the meter or immerse it in water.

---

## **OPTIONAL ACCESSORIES**

Optional accessories available from General Tools & Instruments include:

- Sound level probe and plug adapter
- Type K and Type J thermocouples
- 9VDC adapter for a 110V power supply

---

## **WARRANTY INFORMATION**

General Tools & Instruments' (General's) DLAF930SD Environment Meter with Datalogging SD Card is warranted to the original purchaser to be free from defects in material and workmanship. Subject to certain restrictions, General will repair or replace this instrument if, after examination, the company determines it to be defective in material or workmanship for a period of one year.

This warranty does not apply to damages that General determines to be from an attempted repair by non-authorized personnel or misuse, alterations, normal wear and tear, or accidental damage. The defective unit must be returned to General Tools & Instruments or to a General-authorized service center, freight prepaid and insured.

Acceptance of the exclusive repair and replacement remedies described herein is a condition of the contract for purchase of this product. In no event shall General be liable for any incidental, special, consequential or punitive damages, or for any cost, attorneys' fees, expenses, or losses alleged to be a consequence of any damage due to failure of, or defect in any product including, but not limited to, any claims for loss of profits.

---

## **RETURN FOR REPAIR POLICY**

Every effort has been made to provide you with a reliable product of superior quality. However, in the event your instrument requires repair, please contact our Customer Service to obtain an RGA (Return Goods Authorization) number before forwarding the unit via prepaid freight to the attention of our Service Center at this address:

General Tools & Instruments  
80 White Street  
New York, NY 10013  
212-431-6100

Remember to include a copy of your proof of purchase, your return address, and your phone number and/or e-mail address.

***NOTES***

---

---

---

---

---

---

---

---

---

---

---

---

---

---

---

---

---

---

---

---

---

---

---

---

---



## **Specialty Tools & Instruments**

---

### **GENERAL TOOLS & INSTRUMENTS**

80 White Street  
New York, NY 10013-3567  
PHONE (212) 431-6100  
FAX (212) 431-6499  
TOLL FREE (800) 697-8665  
e-mail: [sales@generaltools.com](mailto:sales@generaltools.com)  
[www.generaltools.com](http://www.generaltools.com)  
DLAF930SD User's Manual

Specifications subject to change without notice

©2010 GENERAL TOOLS & INSTRUMENTS  
NOTICE - WE ARE NOT RESPONSIBLE FOR TYPOGRAPHICAL ERRORS.  
MAN#DLAF930SD 11/26/10