



HWA4214SD

USER'S MANUAL



HOT WIRE ANEMOMETER-THERMOMETER WITH DATALOGGING SD CARD

Please read this manual carefully and thoroughly before using this product.

TABLE OF CONTENTS

Introduction	3
Key Features	4
Operating Instructions	4 – 10
What's in the Case	4 – 5
Setup	6 – 7
Normal Operation	8 – 9
Holding and Storing Measurements.	9
Automatic vs. Manual Datalogging	9 – 10
Transferring Data from the SD Card to a Computer	10
Specifications	11
Maintenance & Troubleshooting Tips	12
Optional Accessories	12
Warranty Information	12
Return for Repair Policy	13

INTRODUCTION

Thank you for purchasing General Tools & Instruments' HWA4214SD Hot Wire Anemometer-Thermometer with Datalogging SD Card. Please read this user's manual carefully and thoroughly before using the instrument.

The HWA4214SD is a general-purpose handheld instrument that can make two kinds of measurements:

- Air (wind) speed and temperature (simultaneously)
- Surface temperature, as measured by an optional Type K or Type J thermocouple

All hot wire anemometers, including the HWA4214SD, have at their heart a very thin metal wire that the instrument electrically heats up above ambient temperature. Air flowing past the wire cools it. The speed of the air flow can be calculated from the relationship between the metal's electrical resistance and temperature. In the HWA4214SD, the hot wire is located at the end of a telescoping probe, where it is paired with a tiny glass bead thermistor that measures air temperature.

Compared to other types of anemometers, hot wire anemometers have superior performance. For this reason, they are commonly used for precise measurement of low-speed air flows, turbulent flows, or of any flow in which rapid velocity fluctuations are of interest. Applications include:

- Environmental testing
- Maintenance and repair of air conveyors and flow hoods in clean rooms
- Measurement of air velocity produced by fans and blowers
- Balancing velocity profiles in furnaces and refrigerated cases
- Operating paint spray booths

The HWA4214SD comes with a telescoping air speed-temperature probe. Air speeds can be displayed in m/s (meters/second), fpm (feet per minute), km/h (kilometers/hr), knots (nautical miles per hour), or mph (miles per hour). Temperatures can be displayed in oF (Fahrenheit) or oC (Celsius) units.

Several features and capabilities enhance the instrument's versatility. Among them are automatic temperature compensation for measurements made by the telescoping probe or by Type K or J thermocouples, the ability to hold readings and display maximum and minimum readings, and an automatic power off function that extends battery life.

Because it is microprocessor-based, the HWA4214SD can make full use of the portability, reliability and large storage capacities that SD memory cards offer. Measurements can be made automatically at any sampling rate between one second and one hour. After storing and time-stamping the measurements on an SD card plugged into the instrument (a process called datalogging), the user can remove the card and plug it into to a laptop or desktop computer either directly or via a USB card reader. The data logs are stored on the card as files with the .xls extension, which can be opened by Microsoft's Excel application.

The HWA4214SD has a backlit 2.5 in. diagonal display and is powered by six "AA" Alkaline batteries or an optional 9-VDC AC adapter.

KEY FEATURES

- Includes telescoping air speed-temperature probe
- Displays air (wind) speed in meters/second, feet per minute, kilometers/hr, knots (nautical miles per hour), or miles per hour
- Measures air speeds down to 0.2 m/s with 0.01 m/s resolution (down to 40 ft/min with 1 ft/min resolution)
- Displays temperature in °F or °C
- Big (2.5 in. diagonal) front-panel green backlit LCD is easy to read
- Displays maximum and minimum readings and holds any reading
- Automatically logs measurements at sampling time settable from one second to one hour
- Also supports manual datalogging and changing of SD card storage location
- Outputs Excel-compatible data logs
- Accepts SD memory cards of up to 16 GB capacity
- Auto power off function
- Powered by six “AA” batteries or optional 9V AC/DC adapter

OPERATING INSTRUCTIONS

WHAT'S IN THE CASE

The HWA4214SD comes fully assembled in a hard carrying case along with a telescoping air speed-temperature probe, a 2 GB SD memory card and this user's manual.

Optional accessories available from General Tools & Instruments include:

- Type K and Type J thermocouples
- A 9VDC adapter for a 110V power supply

See the Optional Accessories section of this manual for more details.

Figure 1 shows all of the controls and indicators on the front, right side, back, top and bottom of the HWA4214SD. It also shows the main components of the included telescoping probe. Familiarize yourself with the positions and functions of these controls, indicators and connectors before moving on to the setup procedure.

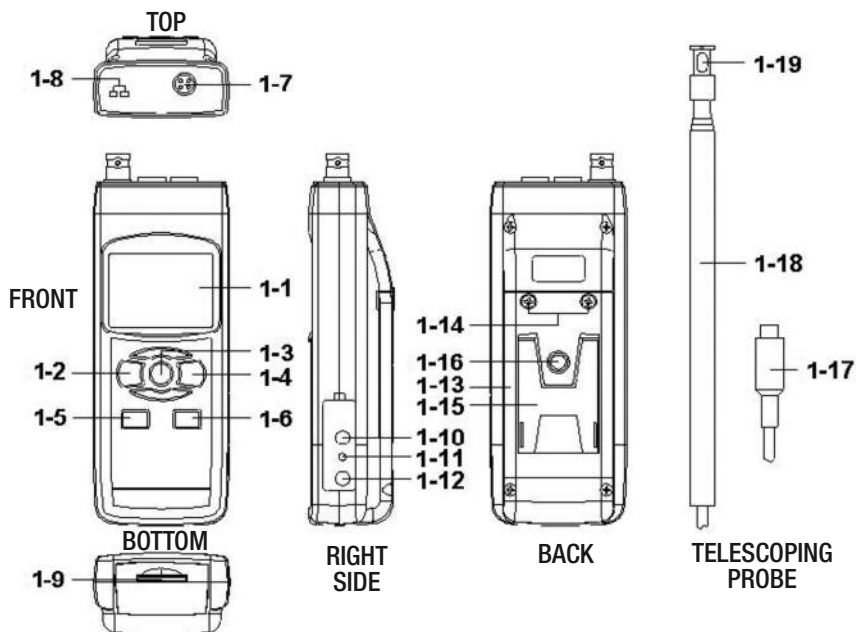

Fig. 1. The HWA4214SD's controls and indicators and other physical features

- | | |
|---|---|
| 1-1 Liquid-crystal display | 1-10 RS-232 output jack |
| 1-2 POWER/ESC button | 1-11 RESET button |
| 1-3 FUNC./HOLD/NEXT button | 1-12 Socket for 9VDC AC adapter |
| 1-4 REC/ENTER button | 1-13 Battery compartment cover |
| 1-5 SET ▼ button | 1-14 Battery compartment cover screws |
| 1-6 LOGGER ▲ button | 1-15 Kickstand |
| 1-7 Socket for combination air
speed-temperature probe | 1-16 Tripod attachment nut |
| 1-8 Socket for optional
Type K or J thermocouple | 1-17 Telescoping probe plug |
| 1-9 SD card socket | 1-18 Telescoping probe handle |
| | 1-19 Telescoping probe sensing head/cover |

SETUP

1. Choose the power source. Before using the HWA4214SD, make sure it is powered by fresh batteries or an optional 9VDC AC adapter plugged into the bottom jack on its right side (callout 1-12).

To remove the battery compartment cover (callout 1-13), remove the two screws holding it in place (callout 1-14). Then install six AA batteries in the correct orientation, using the polarity marks on the inside of the compartment as a guide. Replace the cover by replacing the two screws.

2. Install an SD card. To prepare for setup, also install an optional SD memory card of 1 GB to 16 GB capacity in the socket on the bottom of the instrument (callout 1-9). When installing the card, make sure its gold contacts are facing front and push the card into the socket until you hear a click. To remove the card, push it in until you hear a click and the card pops out.

Now power on the instrument by pressing the POWER/ESC button (callout 1-2) to generate a short beep. (To power off the HWA4214SD, press the POWER/ESC button and hold it until the instrument responds with a long beep.)

When the instrument powers on, a series of transient startup screens will briefly appear. Once the display has stabilized, perform the following eight setup steps in the order presented.

3. Set the date and time. Press the SET ▼ button (callout 1-5) and hold it for at least five seconds, until the word “dAtE” appears in the center of the display, along with the flashing value “00.00.00” at the lower left, above “yy.mm.dd”.

Set the current year by pressing the SET ▼ or LOGGER ▲ button repeatedly until the correct value appears above “yy”. Quickly (within three seconds), press the REC/ENTER button to store the setting. The next screen that appears will have the value above “mm” flashing. Use the SET ▼ or LOGGER ▲ button to navigate to the current month and press the REC/ENTER button to store the setting. When the next screen flashes the value above “dd”, again use the SET ▼ or LOGGER ▲ button to navigate to the current day and press the REC/ENTER button to store the setting.

(If you press buttons too slowly in setup mode, the screen will revert to the normal display. To return to the setup sequence, press and hold the SET ▼ button again. To move ahead to the next field in the sequence or to the next parameter, press the FUNC./HOLD/NEXT button.)

Once you have set the date, the display will prompt you to set the hour, minute and second of the current time. Again use the SET ▼ or LOGGER ▲ buttons to navigate to the correct values, and the REC/ENTER button to store the settings.

4. Choose a decimal point or comma to represent the decimal division between integers and fractions (for example, American-style 20.88 vs. European-style 20,88). Once you have set the date and time, the display will show the word “bASIC” above the phrase “dEC”. Press the SET ▼ button to make “bASIC” (American style) or “Euro” appear in the upper display, as desired. Press the REC/ENTER button to store the selection as the default.

- 5. Enable or disable auto power off.** Once the format of decimal point divisions has been set and stored, the display will show the word “yES” over the term “PoFF”. Press the SET ▼ button until the desired automatic power off management scheme (“yES” for enable; “no” for disable) is displayed. Press the REC/ENTER button to store the selection. If enabled, the power off function shuts off the HWA4214SD after a period of inactivity of ten minutes.
- 6. Enable or disable the beeper.** Once the auto power off function has been enabled or disabled, the display will show the word “yES” over the word “bEEP”. Press the SET ▼ button until the desired setting (“yES” or “no”) is displayed, and then press the REC/ENTER button to store the selection as the default.
- 7. Select the thermocouple type.** Once the beep sound has been enabled or disabled, the lower part of the display will show the term “tYPE”. Press the SET ▼ or LOGGER ▲ button until your thermocouple’s type (K or J) appears on the display. Then press the REC/ENTER button to store the selection.
- 8. Select the temperature unit.** Once the thermocouple type has been selected and stored, the lower part of the display will show the term “t-CF”. Press the SET ▼ or LOGGER ▲ button until the unit you prefer (“F” for Fahrenheit, “C” for Celsius) is displayed. Then press the REC/ENTER button to store the selection as the default.
- 9. Set the datalogging sampling time.** Once the default temperature unit has been set and stored, the display will show a value above the letters “SP-t”. Press the SET ▼ or LOGGER ▲ button to decrease or increase the value until the desired sampling time appears above “SP-t”. The options are 0, 1, 2, 5, 10, 30, 60, 120, 300, 600, 1800 and 3600 seconds (0 seconds to 1 hour).
- 10. Format the SD card.** Once the sampling time has been set and stored, the term “Sd-F” will appear in the lower half of the display. Press the REC/ENTER button.

Pressing the REC/ENTER button causes the word “no” or “yES” to appear over the term “Sd-F”. Press the ▼ button to make a selection. Choose “yES” whenever a new SD card is being used, or when a used card is being repurposed (from use with another SD card instrument or a camera, for example) and all data on it is to be erased. Choose “no” to preserve any data on a card previously used with this instrument.

If you choose “yES”, after you press the REC/ENTER button the instrument will prompt you to confirm that decision by displaying the term “Ent” below “yES” and sounding three beeps. To confirm that you want to begin the erasure/formatting procedure, press the REC/ENTER button. “Ent” will then flash several times and the instrument will sound another three beeps to confirm that the SD card has been erased and formatted.

Once the SD card has been set up, the display will then either return to the first of the eight steps in the setup sequence—setting the current date and time—or show the term “ESC”. If “ESC” appears, press the POWER/ESC button to exit the setup procedure and enter normal operating mode.

NORMAL OPERATION

1. To prepare to make measurements, power on the HWA4214SD and make sure an SD card is firmly seated in the socket on the bottom of the instrument.

The meter can make and display two kinds of measurements:

- Air speed and temperature (simultaneously)
- Surface temperature, as measured by an optional Type K or Type J thermocouple

2. To select the measurement mode, use the FUNC./HOLD/NEXT button. Pressing the button repeatedly toggles between the two modes. When the FUNC./HOLD/NEXT button is released, the selected mode becomes the default until the button is pressed again.

By default, the HWA4214SD uses Celsius units for temperature measurements. If you wish to make Fahrenheit units the default, press the SET ▼ button to enter the setup procedure and perform Step 8.

3. To measure air velocity and temperature simultaneously:

- a. Seat the telescoping probe plug (callout 1-17 of Fig. 1) in its socket (callout 1-7) on the top of the instrument.
- b. Press the FUNC./HOLD/NEXT button until the display shows the term “Air”.
- c. Holding the probe by its handle, slide the sensor cover (callout 1-19) on its end down to expose the sensor. Do not touch the sensor with tools or your fingers; the thin hot wire and thermistor inside it are easily damaged.
- d. Extend the probe to a convenient length.
- e. Rotate the probe until the mark on top of the sensor head faces the wind or the flow of air whose speed/temperature you wish to measure. The upper part of the display will show the air speed while the lower part will show the temperature (as “°F” or “°C”).

To change the unit of air speed, use the REC/ENTER button (which has the word “Unit” stenciled below it). Repeated presses of the button cycle through the five options for air speed units: m/s (meters/second), fpm (feet per minute), km/h (kilometers/hr), knots (nautical miles per hour), and mph (miles per hour). Release the REC/ENTER button when the unit you wish to use appears, making it the default until changed.

4. To measure surface temperature using a thermocouple, make sure the multi-function probe is not in its socket. Plug an optional Type K or Type J thermocouple into its dedicated socket (callout 1-8 of Fig. 1). Then press the FUNC./HOLD/NEXT button until the display shows the term “tP”.

Touch the wire end of the thermocouple to the surface whose temperature you wish to measure. The display will show its temperature (as “°F” or “°C”).

By default, the HWA4214SD is configured for a Type K thermocouple. To use a Type J thermocouple, press the SET ▼ button to enter the setup procedure and perform Step 7.

Whenever the instrument is operating in measurement mode, you can turn off the backlight (which is on by default) by briefly pressing (but not holding) the POWER/ESC button. To reactivate the backlight, briefly press the button again.

Whenever the HWA4214SD is in either measurement mode, you also can check the current date and time by briefly pressing the SET ▼ button (which has the words “Time check” stenciled below it). Doing so causes both values to appear briefly at the lower left of the display.

HOLDING AND STORING MEASUREMENTS

- 1. To hold a measured value**, press the FUNC./HOLD/NEXT button during the measurement. Doing so will cause the word “HOLD” to appear at the top of the display. Pressing the FUNC./HOLD/NEXT button again releases the hold.
- 2. To record and recall readings**, press the REC/ENTER button while making measurements. This will make the term “REC” appear at the top of the display. Pressing the REC/ENTER button again, briefly, will make the term “MAX” appear to the right of “REC” and switch the display to the maximum value stored in memory during the last recording session. Pressing the REC/ENTER button again, briefly, will make the term “MIN” appear to the right of “REC” and switch the display to the minimum value stored during the last session.
- 3. To exit recording mode**, press the REC/ENTER button and hold it for at least three seconds, until the term “REC” disappears from the top line of the display. The display will then revert to showing the current reading.

AUTOMATIC VS. MANUAL DATALOGGING

The HWA4214SD can automatically log data at a user-selected sampling period from 1 second 3,600 seconds (one hour). To view the sampling time that the instrument has been set up to use, press the LOGGER ▲ button (which has the words “Sampling check” stenciled below it) once. To change the sampling time, perform Step 9 of the setup procedure.

- 1. To start automatic datalogging**, press the REC/ENTER button once. The top line of the display will then show the term “REC”. Pressing the LOGGER ▲ button at this point will make REC flash and add the flashing term “LOGGER” at the top right of the display. This indicates that the instrument is currently storing measured values and their time stamps in memory.
- 2. To pause automatic datalogging**, press the LOGGER ▲ button once; this action makes the flashing term “LOGGER” disappear from the top right of the display and changes the term “REC” from flashing to constant. Pressing the LOGGER ▲ button again resumes automatic datalogging.
- 3. To end automatic datalogging**, press the REC/ENTER button and hold it for at least two seconds. This action causes the “REC” message to disappear.
- 4. To log data manually**, set the sampling time to zero using the procedure detailed earlier. Then press the REC/ENTER button once. The display will show the term “REC” on the top line, a value in the middle, and below it the letter “P” on the left and a number from 1 to 99 on the same line to the right. The number indicates the position on the SD card that will be used to store manually logged data.

Now press the **LOGGER ▲** button. This will cause the beeper to sound and the term “LOGGER” to briefly appear at the upper right of the display. As in automatic datalogging mode, in this mode the instrument is storing measurements and their time stamps on the SD card.

In manual datalogging mode, however, measurements are being stored continuously (with a sampling time of zero), and their locations on the card can be changed.

5. To change the storage location of manually logged data, press the **SET ▼** button once; this causes the “P” to disappear from the left side of the display and the value on its line to begin flashing. Once the flashing begins, you can use the **SET ▼** and **LOGGER ▲** buttons to change the flashing value to any number between 1 and 99. Once you have chosen the storage location, press the **REC/ENTER** button to save the setting. This causes the value to stop flashing and the “P” to return.

6. To end manual datalogging, press the **REC/ENTER** button and hold it for at least three seconds. This action causes the “REC” message to disappear from the top line of the display.

TRANSFERRING DATA FROM THE SD CARD TO A COMPUTER

After automatic or manual datalogging of measurements, remove the SD card from the instrument and plug it into your computer either directly (if it has an SD card slot) or through an SD card reader.

Because the files containing time-stamped data logs have the file extension .xls, they open in Microsoft’s Excel application. Figures 2 and 3 show two kinds of Excel presentations: a data-only screen and a graphics-only screen.

	A	B	C	D	E	F	G	H	I	J
1	Place	Date	Time	Value	Unit	Value	Unit			
2		1	2009/6/8	15:12:16	0.8	m/s	28.8	AMTemp	C	
3		2	2009/6/8	15:12:17	2.2	m/s	28.8	AMTemp	C	
4		3	2009/6/8	15:12:18	2.1	m/s	28.8	AMTemp	C	
5		4	2009/6/8	15:12:19	2.9	m/s	28.9	AMTemp	C	
6		5	2009/6/8	15:12:20	2.9	m/s	28.8	AMTemp	C	
7		6	2009/6/8	15:12:21	2.7	m/s	28.8	AMTemp	C	
8		7	2009/6/8	15:12:22	3.6	m/s	28.8	AMTemp	C	
9		8	2009/6/8	15:12:23	2.9	m/s	28.8	AMTemp	C	
10		9	2009/6/8	15:12:24	2.9	m/s	28.8	AMTemp	C	
11		10	2009/6/8	15:12:25	2.9	m/s	28.8	AMTemp	C	
12		11	2009/6/8	15:12:26	2.9	m/s	28.9	AMTemp	C	
13		12	2009/6/8	15:12:27	3	m/s	28.8	AMTemp	C	
14		13	2009/6/8	15:12:28	3.1	m/s	28.8	AMTemp	C	
15		14	2009/6/8	15:12:29	3.1	m/s	28.7	AMTemp	C	
16		15	2009/6/8	15:12:30	5.9	m/s	29.1	AMTemp	C	
17		16	2009/6/8	15:12:31	4.2	m/s	29	AMTemp	C	
18		17	2009/6/8	15:12:32	3.2	m/s	28.9	AMTemp	C	
19		18	2009/6/8	15:12:33	2.6	m/s	28.6	AMTemp	C	
20		19	2009/6/8	15:12:34	3.1	m/s	28.7	AMTemp	C	
21		20	2009/6/8	15:12:35	3	m/s	28.7	AMTemp	C	
22		21	2009/6/8	15:12:36	3	m/s	28.9	AMTemp	C	
23		22	2009/6/8	15:12:37	3.1	m/s	28.9	AMTemp	C	
24		23	2009/6/8	15:12:38	2.8	m/s	28.9	AMTemp	C	

Fig. 2. Typical Excel data-only screen

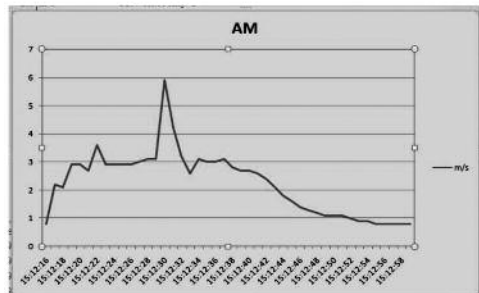



Fig. 3. Typical Excel graphics-only screen

SPECIFICATIONS

Embedded microcontroller	Custom one-chip LSI device
Display type	Liquid-crystal with green backlight
Display size	2.05 x 1.5 in. (52 x 38mm)
Parameters measured	Air speed, temperature
Measurement range	For temperature, 32° to 122°F (0° to 50°C); for air speed: 0.2 to 25 m/sec, 0.7 to 172 km/hr, 0.5 to 44.7 mph, 0.4 to 38.8 knots, 40 to 3940 ft/min
Measurement accuracy	For air speed: $\pm (5\% + 0.1 \text{ m/sec})$, $\pm (5\% + 0.3 \text{ km/hr})$, $\pm (5\% + 0.2 \text{ mph})$, $\pm (5\% + 0.2 \text{ knots})$, $\pm (5\% + 20 \text{ ft/min})$; for temperature: $\pm 1.5^\circ\text{F}$ ($\pm 0.8^\circ\text{C}$)
Measurement resolution	For air speed: 0.01 m/s (0.2 to 5.0 m/s), 0.1 m/s (5.1 to 25.0 m/s); 0.01 km/hr (0.7 to 18 km/hr), 0.1 km/hr (18 to 72 km/hr); 0.01 mph (0.5 to 11.20 mph), 0.1 mph (11.2 to 44.7 mph); 0.01 knot (0.4 to 9.7 knots), 0.1 knot (9.7 to 38.8 knots); 1 ft/min (40 to 3940 ft/min); for temperature, 0.1 °F or C
Sampling time options	0, 1, 2, 5, 10, 30, 60, 120, 300, 600, 1800 or 3600 seconds (0 seconds to 1 hour)
Settable parameters	Date, time, auto power off, beep sound, sampling time, decimal point or comma decimal division, temperature unit, air speed unit, optional thermocouple type (K or J)
Storable/recallable readings	Maximum, minimum
SD card capacity	1 GB to 16 GB
Operating temperature	32° to 122°F (0° to 50°C)
Operating relative humidity	0 to 85%
Power supply	Six Alkaline “AA” batteries or optional 9-VDC AC adapter
Power consumption	30 mADC (normal operation, with backlight off and SD card not saving data); 50 mADC (with backlight on and card saving data)
Dimensions of instrument	7.99 x 2.99 x 1.50 in. (203 x 76 x 38mm)
Weight of instrument	1.13 lb. (515g)
Dimensions of probe	0.4724 in. (diameter) x 11.02 in. (collapsed)/37 in. (extended) (12mm x 280mm/940mm)

MAINTENANCE & TROUBLESHOOTING TIPS

Keep the telescoping probe clean and move the sensor cover at its tip to the up position when not using the probe. Store the probe in the carrying case when you are not using the anemometer.

When the icon  appears in the left corner of the display, it's time to replace the six "AA" batteries that power the instrument (although measurements will remain valid for several hours after the low-battery indicator first appears). Replacing the batteries requires removing the two screws that hold the battery compartment cover in place, as explained in Step 1 of the Setup procedure. After inserting fresh batteries in the correct orientation, tighten the screws to secure the cover.

If the meter "freezes" (like a computer) and buttons become unresponsive, try resetting the instrument by pushing the RESET button on its right side (callout 1-11 of Fig. 1) with the end of a paper clip.

Remove the batteries when storing the meter for an extended period of time.

Do not drop or disassemble the meter or immerse it in water.

OPTIONAL ACCESSORIES

Optional accessories available from General Tools & Instruments include:

- Type K and Type J thermocouples
- 9VDC adapter for a 110V power supply

WARRANTY INFORMATION

General Tools & Instruments' (General's) HWA4214SD Hot Wire Anemometer-Thermometer with Datalogging SD Card is warranted to the original purchaser to be free from defects in material and workmanship for a period of one year. Subject to certain restrictions, General will repair or replace this instrument if, after examination, the company determines it to be defective in material or workmanship.

This warranty does not apply to damages that General determines to be from an attempted repair by non-authorized personnel or misuse, alterations, normal wear and tear, or accidental damage. The defective unit must be returned to General Tools & Instruments or to a General-authorized service center, freight prepaid and insured.

Acceptance of the exclusive repair and replacement remedies described herein is a condition of the contract for purchase of this product. In no event shall General be liable for any incidental, special, consequential or punitive damages, or for any cost, attorneys' fees, expenses, or losses alleged to be a consequence of any damage due to failure of, or defect in any product including, but not limited to, any claims for loss of profits.

RETURN FOR REPAIR POLICY

Every effort has been made to provide you with a reliable product of superior quality. However, in the event your instrument requires repair, please contact our Customer Service to obtain an RGA (Return Goods Authorization) number before forwarding the unit via prepaid freight to the attention of our Service Center at this address:

General Tools & Instruments
80 White Street
New York, NY 10013
212-431-6100

Remember to include a copy of your proof of purchase, your return address, and your phone number and/or e-mail address.



Specialty Tools & Instruments

GENERAL TOOLS & INSTRUMENTS

80 White Street
New York, NY 10013-3567
PHONE (212) 431-6100
FAX (212) 431-6499
TOLL FREE (800) 697-8665
e-mail: sales@generaltools.com
www.generaltools.com
HWA4214SD User's Manual

Specifications subject to change without notice

©2010 GENERAL TOOLS & INSTRUMENTS
NOTICE - WE ARE NOT RESPONSIBLE FOR TYPOGRAPHICAL ERRORS.
MAN#HWA4214SD 6/9/11