



The Touchpoint 1 controller provides 24 hour protection from flammable, toxic or oxygen gas hazards.

Touchpoint 1 controller



User Friendly

- Self contained, wall mounted enclosure
- Ultra-clear backlit display
- Built-in audiovisual alarms
- Intuitive menu system
- Simple push button operation

Easy to Install

- Unobtrusive slimline profile
- Mounting bracket included
- Easy access to all terminals
- Pre-formed knockouts in gland plate

Comprehensive Operation

- 3 wire mV bridge, 2 and 3 wire 4-20mA inputs
- AC and/or DC operation
- 2 x alarm relays
- 1 x system fault relay
- Repeated 4-20mA signal

Flexible Operation

- Fully user programmable for scale, units and calibration
- Relays configurable as energized, de-energized, latching or non-latching
- Compatible with all Sensepoint gas detectors

The Touchpoint 1 controller when used with any one of the Sensepoint range of gas detectors provides 24 hour protection from flammable, toxic or oxygen gas hazards. With executive outputs to shutdown process equipment or drive warning devices the Touchpoint 1 is ideal for continuous monitoring of small remote sites where it is inappropriate or costly to monitor the area from a central location.



The shallow profile is designed for convenient location in corridors or reception areas where some larger controllers may be obtrusive. A wall mounting bracket is included to which the controller is attached, thereby simplifying installation. All cable entries are made via a gland plate at the bottom of the enclosure which includes pre-defined knockouts to minimize risk of damaging the connection terminals. The hinged front cover latches open to enable full and unhindered access to the terminal compartment for installers.

AC and/or DC driven, the Touchpoint 1 includes built-in audiovisual alarms, two programmable alarm relays and a system fault relay as well as an isolated 4-20mA output proportional to the input from the field device. The system is fully user programmable via the ultra-clear backlit LCD and intuitive menu system. For example, relays may be configured as 'non-latching' (default is 'latching') so that outputs clear automatically on remote unmanned sites. Buttons used for configuration are hidden behind an access panel to prevent tampering. A single button is available to all users on the front of the controller to perform a simple self-test or to reset alarms if needed.

Event history is recorded as standard on all Touchpoint systems. Times and dates of alarms, power on or off, can be reviewed via the display to provide useful diagnostic information for service engineers and plant operators.

A Honeywell Analytics' gas detection system is designed to offer a total solution for your gas monitoring needs. Manufactured to the highest quality standards, you are assured of being surrounded by gas detection equipment you can trust.

Installation Details



Installation Details

Touchpoint 1 is designed for use in safe areas. Electrical installation should follow national guidelines using suitably approved cable and glands (M20 or 3/4"NPT) or conduit (3/4"NPT). Screened 0.5mm² (20AWG) to 2.5mm² (14AWG) cross sectional area cable should be used where appropriate to minimize unwanted effects from RF sources.

The Touchpoint 1 controller is designed to offer easy and convenient installation. The wall mounting bracket provided serves as a drilling template and enables the controller to be mounted without assistance.

The hinged terminal cover can be latched open to provide free and unhindered access to all terminals with plenty of space for all wiring.

The pre-formed knockouts in the base are sized for both M20 and 3/4"NPT fittings enabling cable glands or conduit to be used during installation.

System Highlights

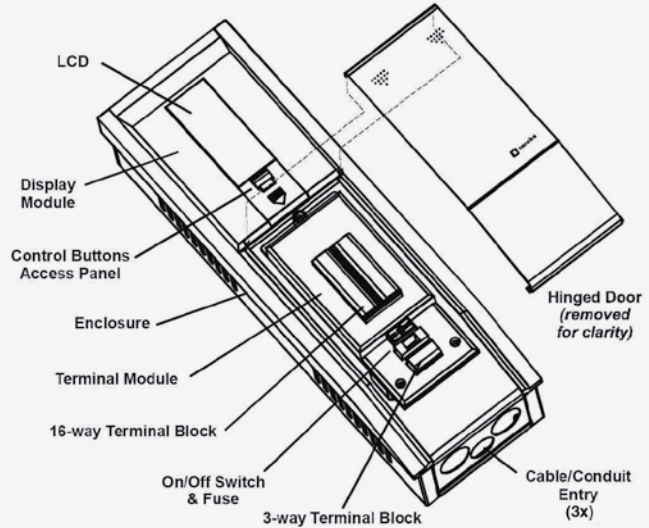

Dimensions

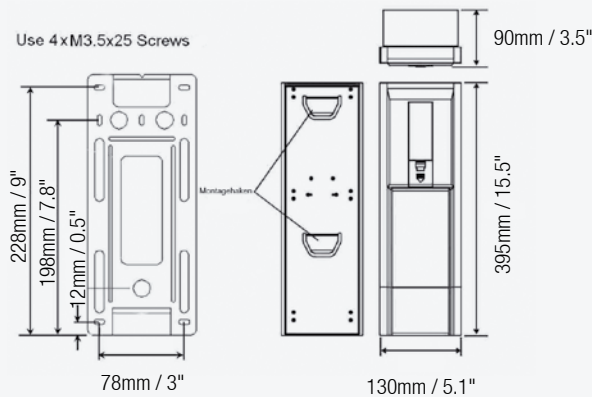

Sensepoint Flammable

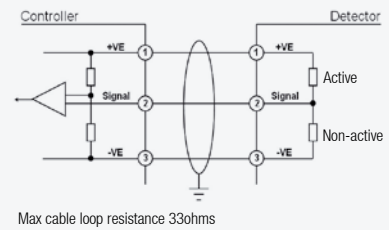

Sensepoint Toxic & Oxygen

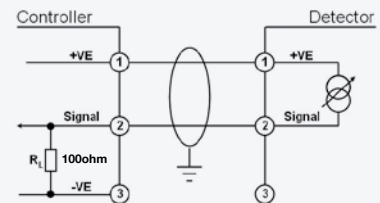

Sensepoint Plus & Pro (all versions)

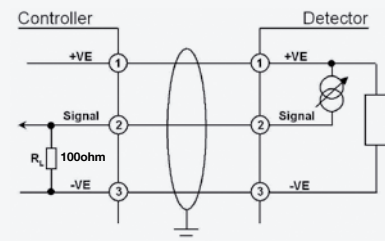

Terminal Layout

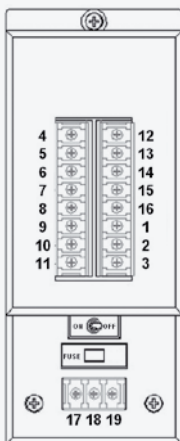

Connections

1	+VE	Detector Connections
2	SIGNAL	
3	-VE	
4	NO	Alarm Relay 1
5	C	
6	NC	
7	NO	Fault Relay
8	C	
9	NC	
10	DC+	DC Supply 18-32VDC
11	DC-	
12	NO	Alarm Relay 2
13	C	
14	NC	
15	+VE	Isolated 4-20mA Output
16	-VE	
17	(L)ive	AC Supply 85-265Vac 50/60Hz
18	(N)eutral	
19	(E)arth	

Ordering Information



General Specification			
Use	Wall mounted single channel control panel for the local annunciation of gas hazards as detected by the range of Sensepoint gas detectors. Suitable for small scale, indoor installations requiring a self contained gas detection and control system		
User interface			
Operation	Single 'Test/Accept/Reset' push button for normal use. Three further hidden push buttons for configuration via intuitive menu system		
Backlit Display	Gas type, measuring range, units of measure, digital gas reading, bar graph display 0-100% FSD, alarm set point indicator, alarm activated indicator, power status indicator and system status indicator		
Other Indication	Three ultra-bright LEDs indicating alarm (red), power (green) and fault (amber) status		
Audible Alarm	85dBA at 1 m / 90dBA at 1 foot, user hush facility, re-activated on new event		
Termination	Accessed via hinged front cover (latch to hold open as required). All cable/conduit entry via pre-formed knockouts in gland plate at bottom of controller. Screw terminals suitable for use with 0.5mm ² (20AWG) to 2.5mm ² (14AWG) wires. Crimped connection recommended		
Environmental			
IP Rating	Indoor use, IP44 in accordance with EN60529:1992		
Weight	2.5kg / 5.5lbs (approx.)		
Operating Temp Range	-10°C to +40°C / 14°F to 104°F Intermittent to +50°C / 122°F		
Operating Humidity Range	10 to 90%RH (non condensing)		
Operating Pressure Range	90-110kPa		
Storage	-40°C to +80°C / -40°F to +176°F, 20 to 80%RH (non condensing)		
Inputs			
Supply	85-265Vac, 50/60Hz auto-sensing 18-32Vdc Maximum power = 30Wac / 15Wdc		
Detector Type	3 wire mV bridge e.g. Sensepoint flammable gas detectors	2 wire, 4-20mA, loop powered e.g. Sensepoint toxic and Oxygen gas detectors	3 wire, 4-20mA, source output e.g. Sensepoint Plus and Sensepoint Pro flammable, toxic and Oxygen gas detectors
Detector Supply	mV Bridge Input Module Constant current supply: 200mA Self regulating supply voltage subject to cable resistance Maximum loop resistance: 18 Ohms	mA Input Module Maximum detector current supply: 500mA Minimum guaranteed supply voltage from the controller: 18Vdc Input impedance: 100 Ohms	
Outputs			
Relays	Alarm 1	Alarm 2	Fault
Rating	SPCO / 3A, 240VAC (non inductive load)	SPCO / 3A, 240VAC (non inductive load)	SPCO / 3A, 240VAC (non inductive load)
Default Setting	Latching Normally de-energized Energize on alarm Factory setting 20%FSD	Latching Normally de-energized Energize on alarm Factory setting 40%FSD	Latching Normally energized De-energize on fault or loss of power
User Configurable Options	Latching/non-latching Energized/de-energized Rising/falling (Oxygen) Trip point 10-90%FSD	Latching/non-latching Energized/de-energized Rising/falling (Oxygen) Trip point 10-90%FSD	Latching/non-latching Energized/de-energized

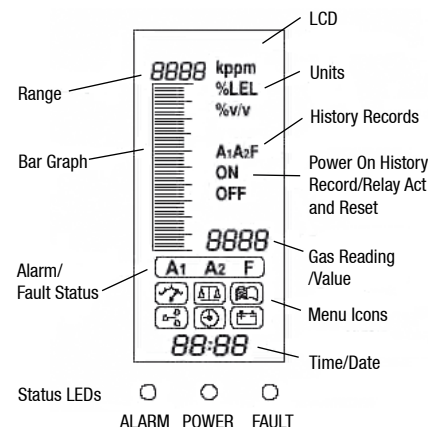

Installation Details



Ordering Information

TPWM1110	Single channel system with mA input module
TPWM1101	Single channel system with mV input module

For Reference Only

Detector	Gas Type	No. Wires	Input Module Required
Signalpoint	Flammable	3	mV
	Toxic	2	mA
Sensepoint	Flammable	3	mV
	Toxic	2	mA
Sensepoint Plus	Flammable	3	mA
	Toxic	3	mA
Sensepoint Pro	Flammable	3	mA
	Toxic	3	mA

Standard Supply Each Touchpoint controller is supplied complete with mounting bracket, instruction manual and configured mV or mA input module with factory default settings

Shipping Details Shipping carton dimensions: L446mm (17.6") x W207mm (8.1") x D183mm (7.2")
Approximate weight: 2.8kg (6.2lbs)

System Overview

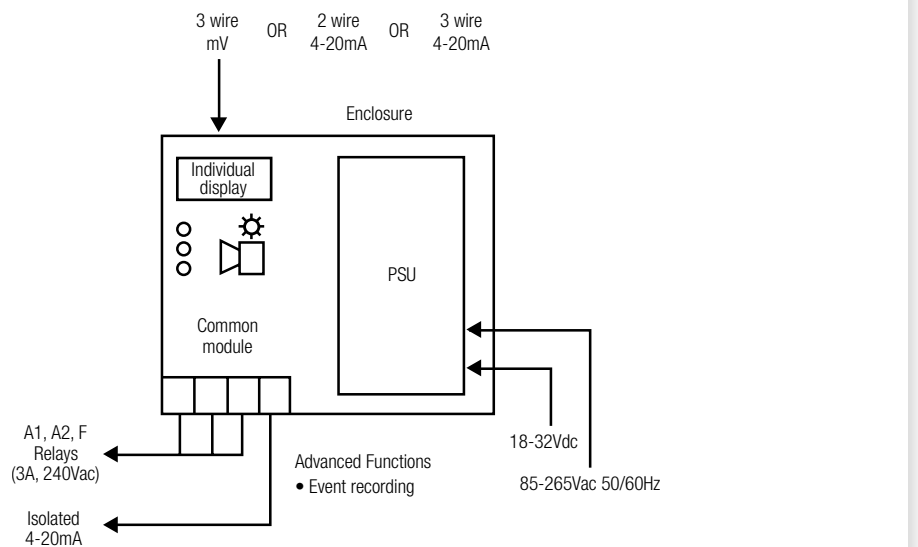

Our Product Range



Fixed Gas Monitoring

Honeywell Analytics offers a wide range of fixed gas detection solutions for a diverse array of industries and applications including: Commercial properties, industrial applications, semiconductor manufacturers, energy plants and petrochemical sites.

- » Detection of flammable, oxygen and toxic gases (including exotics)
- » Innovative use of 4 core sensing technologies – paper tape, electrochemical cell, catalytic bead and infrared
- » Capability to detect down to Parts Per Billion (ppb) or Percent by Volume (%v/v)
- » Cost effective regulatory compliance solutions

Portable Gas Monitoring

When it comes to personal protection from gas hazards, Honeywell Analytics has a wide range of reliable solutions ideally suited for use in confined or enclosed spaces.

These include:

- » Detection of flammable, oxygen and toxic gases
- » Single gas personal monitors – worn by the individual
- » Multi-gas portable gas monitors – used for confined space entry and regulatory compliance
- » Multi-gas transportable monitors – used for temporary protection of area during site construction and maintenance activities

Technical Services

At Honeywell Analytics, we believe in the value of great service and customer care. Our key commitment is providing complete and total customer satisfaction. Here are just a few of the services we can offer:

- » Full technical support
- » Expert team on hand to answer questions and queries
- » Fully equipped workshops to ensure quick turnaround on repairs
- » Comprehensive service engineer network
- » Training on product use and maintenance
- » Mobile calibration service
- » Customised programmes of preventative/corrective maintenance
- » Extended warranties on products

Find out more

www.honeywellanalytics.com

Contact Honeywell Analytics:

Europe, Middle East, Africa

Life Safety Distribution AG
Wilstrasse 11-U31
CH-8610 Uster
Switzerland
Tel: +41 (0)44 943 4300
Fax: +41 (0)44 943 4398
gasdetection@honeywell.com

Americas

Honeywell Analytics Distribution, Inc.
405 Barclay Blvd.
Lincolnshire, IL 60069
USA
Tel: +1 847 955 8200
Toll free: +1 800 538 0363
Fax: +1 847 955 8208
detectgas@honeywell.com

Asia Pacific

Honeywell Analytics Asia Pacific
#508, Kolon Science Valley (1)
187-10 Guro-Dong, Guro-Gu
Seoul, 152-050,
Korea
Tel: +82 (0)2 2025 0307
Fax: +82 (0)2 2025 0329
analytics.ap@honeywell.com

Technical Services

ha.emea.service@honeywell.com

www.honeywell.com

Please Note:

While every effort has been made to ensure accuracy in this publication, no responsibility can be accepted for errors or omissions. Data may change, as well as legislation, and you are strongly advised to obtain copies of the most recently issued regulations, standards, and guidelines. This publication is not intended to form the basis of a contract.

H_Touchpoint1_DS0324_V3_EMEA

09/07

© 2007 Honeywell Analytics

Honeywell