

OPERATION MANUAL

MODEL 207

Loop powered process indicator

JENCO ELECTRONICS, LTD.

MANUFACTURER OF PRECISION INSTRUMENTS

General introduction

The model 207 is a high performance, industrial grade, loop powered process indicators. The model 207 can be user programmed for 4-20 mA or 10-50 mA operations.

Internal dip switches in conjunction with the ZERO and SPAN controls, decimal point position select, dummy zero select and polarity select allow the models 207 to be scaled to display in any engineering units.

INITIAL INSPECTION

Carefully unpack the instrument and accessories. Inspect for damage in shipment. If any damage is found, notify your JENCO REPRESENTATIVE IMMEDIATELY. All packing material should be saved until satisfactory operation is confirmed.

Mounting procedure

1. Make a cutout on any panel, with a thickness of 1/16 in. (1.5mm) to 3/8 in. (9.5 mm). Refer to DRAWING 1.
2. Remove the mounting bracket assemblies from the panel meter and insert the panel meter into the cutout. Refer to DRAWING 2
3. Replace the mounting bracket assemblies onto the panel meter and fasten the mounting screws to secure the panel meter to the mounting panel. Refer to DRAWING 3.

WIRING SCHEME

Connect the current loop to the + and - terminals of the instrument .

- 1.For current transmitters without power source, refer to figure Drawing 4.
2. For current transmitters with power source, refer to Drawing 5.

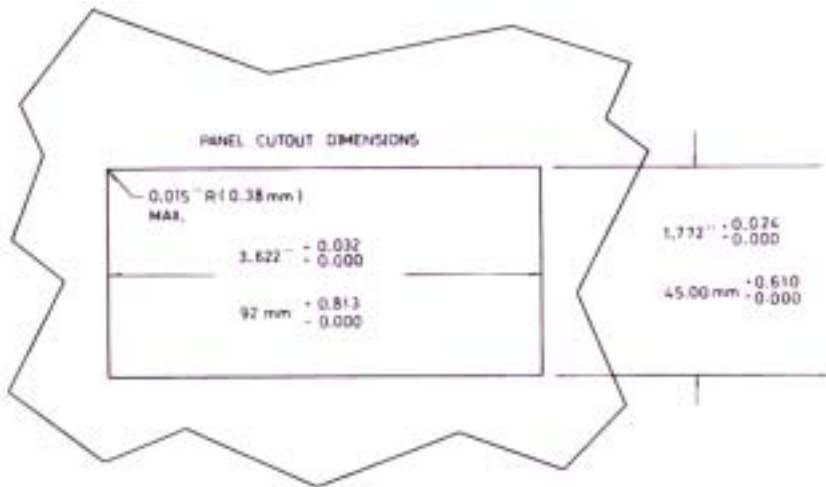

**Panel cutout
Drawing 1**

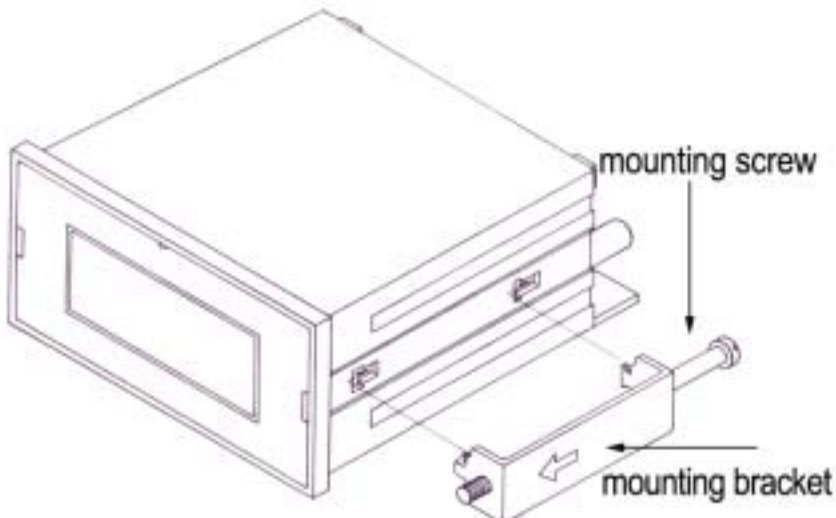

Panel meter with mounting bracket and screw
Drawing 2

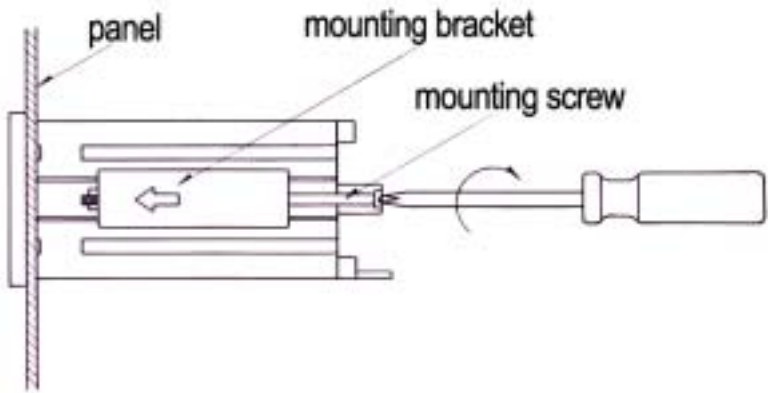

Mounting method
Drawing 3

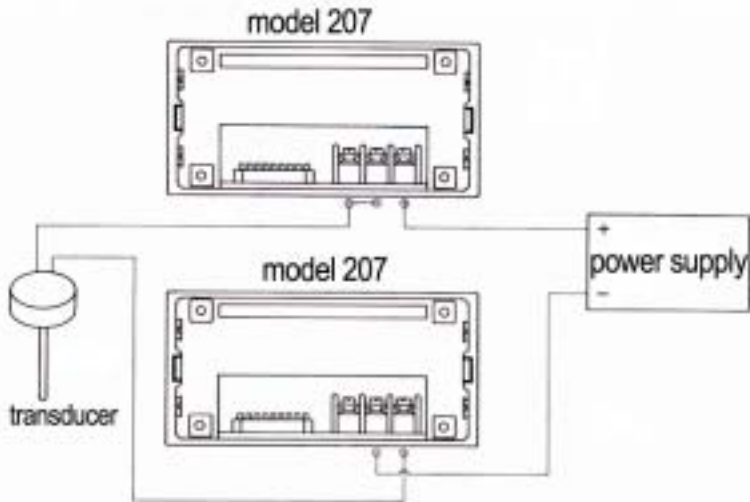

Transmitters without internal power supply

Drawing 4

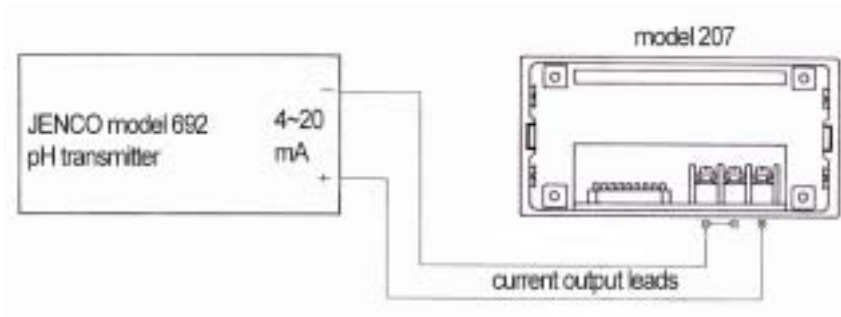

Transmitters with internal power supply
Drawing 5

INPUT RANGES FOR THE MODEL 207

4 to 20mA, 10-50 mA

DECIMAL POINT AND "DUMMY ZERO"

The model 207 is a 3 1/2 digit indicator with a "dummy zero". The following shows the maximum displayed value with and without the dummy zero for different decimal point settings.

Without "dummy zero" SW2.4 in the off position	With "dummy zero" SW2.4 in the on position
1.999	1.9990
19.99	19.990
199.9	199.90

Polarity

The polarity switch changes the polarity of the display without changing it's absolute reading .For absolute polarity ,the switch setting is at the Off position.

Polarity with switch set to Off	polarity with switch set to On
100.0	-100.0
-100.0	100.0

The “+” sign isn’t displayed.

SETTING UP THE INSTRUMENT

Refer to DIP switch DRAWING 6.

1. Connect the model 207 to the current loop. Be sure to observe the polarity of the input leads. Refer to DRAWING 4 and DRAWING 5.

2. Set DIP switch SW1.1 for the appropriate transmitter output, 4-20 mA/10-50 mA.

3. Set one of the SPAN DIP switches SW2.6, SW2.7, SW2.8, SW2.9, to the ON position for the desired SPAN range.

3.1 SPAN is defined as the absolute value of the maximum displayed value less the minimum displayed value. Decimal point and "dummy zero X" is to be ignored.

3.2 Example :

Desired displayed value for 4 mA input is -10.OX.

Desired displayed value for 20 mA input is 100.OX.

The SPAN is 1100.

The SPAN DIP switch SW2.9 is to be set to the ON position.

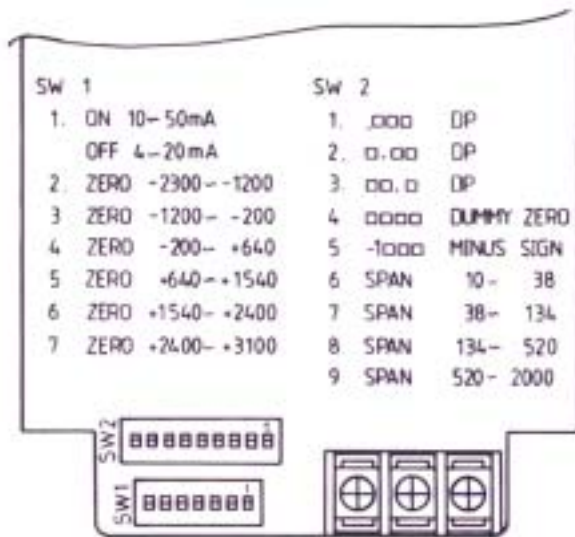

Dip switch format drawing 6

4. Set one of the ZERO DIP switches SW1.2 to SW1.7 to the ON position for the desired ZERO range.
5. Set one of the DIP switches SW2.1, SW2.2, SW2.3 to the ON position for the desired decimal point location.
6. Set DIP switch SW2.5 for the polarity of the display. Refer to page 9.
7. Set DIP switch SW2.4 to the ON position to display the "dummy zero".

CALIBRATION PROCEDURES FOR DIFFERENT DISPLAY VALUES

Remove the front facia plate to access the ZERO and SPAN adjustment controls. Refer to DRAWING 7.

1. Input a stable 4(10) mA current source to simulate the ZERO, minimum transmitter output.
2. Adjust the ZERO control for the desired displayed value.

3. Input a stable 20(50) mA current source to simulate the maximum transmitter output.
4. Adjust the SPAN control for the desired displayed value.
5. Repeat 1 to 4 until both desired readings are obtained.
6. Check the input current, source values and the DIP switch settings, if the desired readings can not be obtained.

CASCADING MORE THAN ONE MODEL 207 IN A SINGLE CURRENT LOOP

More than one of the model 207 can be used in a single current loop. Refer to DRAWING 4. The maximum number of units that can be cascaded depends on the minimum transmitter input voltage requirement and the power supply voltage. The calculation for the maximum number of units that can be cascaded in a single loop is shown below.

$$V_p - [N \times V_{max}] > V_t$$

Where V_p is the power supply voltage

N is the number of model 207

V_{max} is the maximum voltage drop across the model 207

V_t is the minimum voltage required to power the transmitter

For $V_p = 48$ volts, $V_t = 12$ volts Since $V_{max} = 3.7$ volts

The maximum number of the model 207 that can be cascaded is 9. Since $48 - (9 \times 3.7) = 14.7$, the power input to the transmitter is 14.7 volts. Cascading 10 of the model 207 will reduce the power input to the transmitter to 11 volts, less than V_t .

WARRANTY

Jenco Instruments, Ltd. Warrants this product to be free from significant deviations in material and workmanship for a period of 1 year from date of purchase. If repair or adjustment is necessary and has not been the result of abuse or misuse, within the year period, please return-freight-prepaid and the correction of the defect will be made without charge. If you purchased the item from our Jenco distributors and it is under warranty, please contact them to notify us of the situation. Jenco Service Department alone will determine if the product problem is due to deviations or customer misuse.

Out-of –warranty products will be repaired on a charge basis.

RETURN OF ITEMS

Authorization must be obtained from one of our representatives before returning items for any reason. When applying for authorization, please have the model and serial number handy, including data regarding the reason for return. For your protection, items must be carefully packed to prevent damage in shipment and insured against possible damage or loss. Jenco will not be responsible for damage resulting from careless or insufficient packing. A fee will be charged on all unauthorized returns.

NOTE: Jenco Instruments, Inc reserves the right to make improvements in design, construction, and appearance of our products without notice.

JENCO INSTRUMENTS, INC.

7968 Arjons Drive, Suite C San Diego, CA 92126 USA

TEL: 001-858-5782828 FAX: 001-858-5782886

E-MAIL: jencoi@ix.netcom.com

JENCO ELECTRONICS, LTD.

PO. BOX LINKOU 117 TAIPEI, TAIWAN

TEL: (886-2)2601-6191 FAX: (886-2)2601-7206

E-MAIL: jencoe@ms2.hinet.net

SHANGHAI JENCO ELECTRONICS, LTD.

18 Wang Dong Zhong Road Sijing Town, Songjiang SHANGHAI, CHINA

TEL: (86-021)5761-9599 FAX: (86-021)5761-9598

E-MAIL: jenco@public.sta.net.cn

Website: www.jenco.com.cn