

OPERATION MANUAL



MODEL 791

Temperature transmitter

JENCO ELECTRONICS, LTD.

MANUFACTURER OF PRECISION INSTRUMENTS

GENERAL INTRODUCTION

The model 791 is an indicating digital temperature with isolated 4-20 mA output. The metal case of the model 791 is isolated from circuit ground. This allows the metal case to be mounted to grounded or ungrounded panels, without affecting the temperature sensor. The isolated 4-20 mA output allows the output to be transmitted to areas of different ground potentials.

Since the model 791 has its own independent power supply for the current loop, it is not necessary to provide any power source at the receiving end. The internal power source allows the model 791 to directly drive any commercially available loop powered process indicator.

Another feature of the model 791 is that it has independent user adjustable center point and range, control for the 4-20 mA current output.

4-20 mA OUTPUT.

1. Normal mode.

When the exp/norm Switch is set to the NORM position, the output of the transmitter is pre-set to cover the span of the measurement range. 4 mA at the lowest temperature and 20 mA at the highest temperature. The temperature value can be obtained by measuring the transmitter output current. A based on the following equation.

$$\text{Temperature} = (A-4) \times (5\text{SPAN}/16) + (\text{Min TEMP})$$

Example :

Temperature range : -200 to +1200 °C

For A = 12 mA

$$\text{Temperature} = (12-4) \times (1400/16) + (-200) = 500 \text{ °C}$$

2. Expanded mode

When the EXF/NORM switch is set to the EXP position, the output of the transmitter is adjustable. Use the following procedures to set the center point, 12 mA point, and the desired temperature range for the 4-20 mA current output.

2.1 Connect the two leads of a DC ameter to the two transmitter output. The internal resistance of the DC ameter should be less than 600 Ohms.

2.2 Set the instrument, to indicate the desired center point temperature value by changing the thermocouple temperature or by means of a stable DC voltage.

- 2.3 Adjust the CENTER POINT control for the DC ammeter to indicate 12 mA.
- 2.4 Set the instrument to indicate the desired upper point temperature value as in 2.2.
- 2.5 Adjust the TEMP RANGE control for the DC ammeter to indicate 20 mA.
- 2.6 The transmitter output will be 4 mA at the center point temperature value minus the difference in temperature between the upper and center points.
3. The maximum load for the 4-20 mA current output is 600 Ohms.

OUTPUT ISOLATION

The transmitter output ground is isolated from the temperature measuring circuitry. Since the temperature measuring circuitry is also isolated from earth ground, the voltage at the sensor input can differ greatly to that of the transmitter output without introducing errors to the measurement system.

Thermocouple open circuit detection

The model 791 has builtin thermocouple break indication. The display will indicate +1 XXX when the input thermocouple is open, where X indicate blank.

MOUNTING PROCEDURE

1. Make a cutout on any panel, with a thickness of 1/16 in. (1.5 mm) to 3/8

- in. (9.5 mm). Refer to Drawing 1.
2. Remove the mounting screws and mounting brackets from the panel meter and insert the panel meter into the cutout. Refer to Drawing 2.
3. Slide the mounting brackets onto the panel meter and fasten the mounting screws to secure the panel meter to the mounting panel. Refer to Drawing 3.

WIRING DIAGRAM

1. Connect the AC line to the rear of the instrument. The ground lead from the AC line should be connected to EARTH ground. Refer to Drawing 4.

2. Connect the two thermocouple leads to the rear of the instruments. Be sure to observe the polarity of the thermocouple leads. Refer to Drawing 4.
3. Set the EXP/NORM switch on the rear panel to NORM.

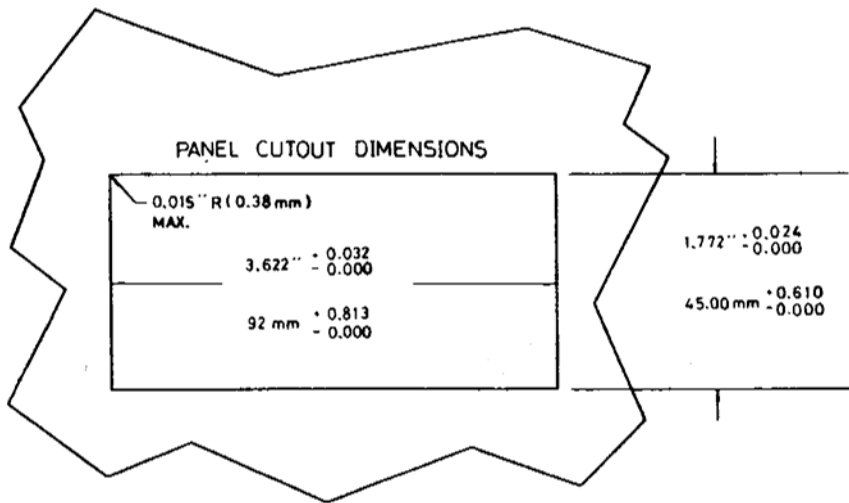

**Panel cutout
Drawing 1**

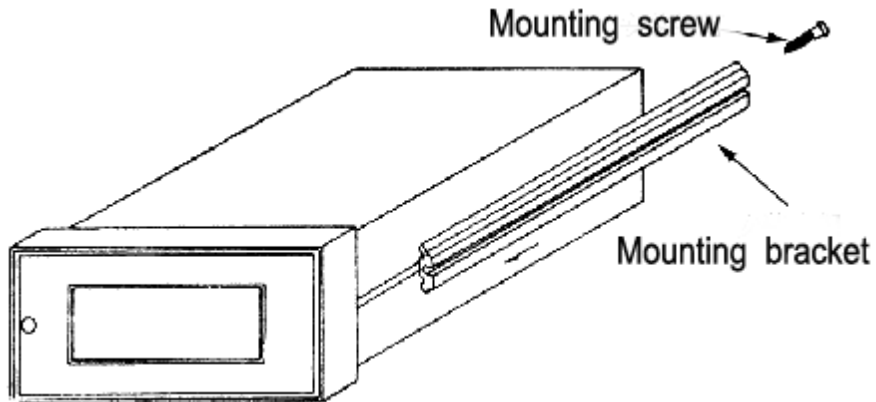

**Panel meter mounting bracket and screw
Drawing 2**

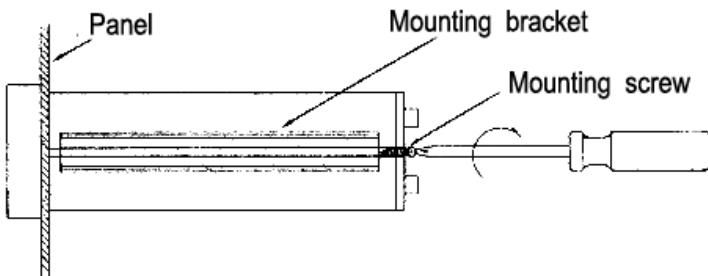

Mounting method
Drawing 3

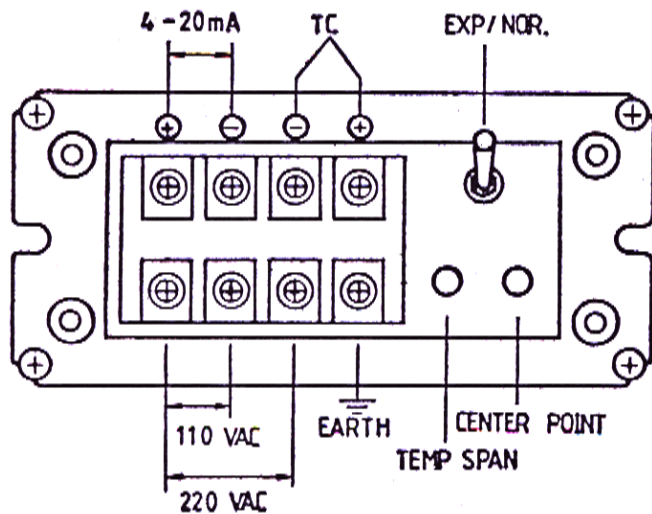

Rear panel wiring diagram

Drawing 4

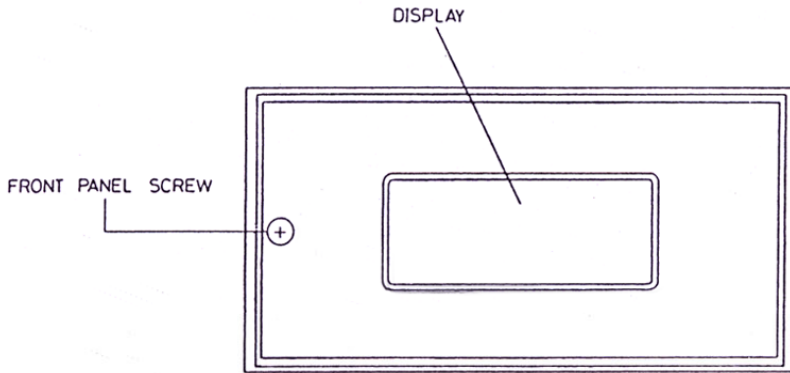

**Front panel diagram
Drawing 5**

WARRANTY

Jenco Instruments, Ltd. Warrants this product to be free from significant deviations in material and workmanship for a period of 1 year from date of purchase. If repair or adjustment is necessary and has not been the result of abuse or misuse, within the year period, please return-freight-prepaid and the correction of the defect will be made without charge. If you purchased the item from our Jenco distributors and it is under warranty, please contact them to notify us of the situation. Jenco Service Department alone will determine if the product problem is due to deviations or customer misuse.

Out-of –warranty products will be repaired on a charge basis.

RETURN OF ITEMS

Authorization must be obtained from one of our representatives before

returning items for any reason. When applying for authorization, please have the model and serial number handy, including data regarding the reason for return. For your protection, items must be carefully packed to prevent damage in shipment and insured against possible damage or loss. Jenco will not be responsible for damage resulting from careless or insufficient packing. A fee will be charged on all unauthorized returns.

NOTE: Jenco Instruments, Inc reserves the right to make improvements in design, construction, and appearance of our products without notice.

JENCO INSTRUMENTS, INC.

7968 Arjons Drive, Suite C San Diego, CA 92126 USA

TEL: 001-858-5782828 FAX: 001-858-5782886

E-MAIL: jencoi@ix.netcom.com

JENCO ELECTRONICS, LTD.

PO. BOX LINKOU 117 TAIPEI, TAIWAN

TEL: (886-2)2601-6191 FAX: (886-2)2601-7206

E-MAIL: jencoe@ms2.hinet.net

SHANGHAI JENCO ELECTRONICS, LTD.

18 Wang Dong Zhong Road Sijing Town, Songjiang SHANGHAI ,CHINA

TEL: (86-021)5761-9599 FAX: (86-021)5761-9598

E-MAIL: jenco@public.sta.net.cn

Website: www.jenco.com.cn