

Part #112920-001

Product Manual:

Model #1000
Centrifugal Blower



PELSUE[®]
ISO 9001 Certified

T.A. Pelsue Company
2500 South Tejon Street
Englewood, Colorado, USA 80110
Tel. 800-525-8460 or 303-936-7432
Fax. 303-934-5581
Internet: www.pelsue.com
Email: sales@pelsue.com

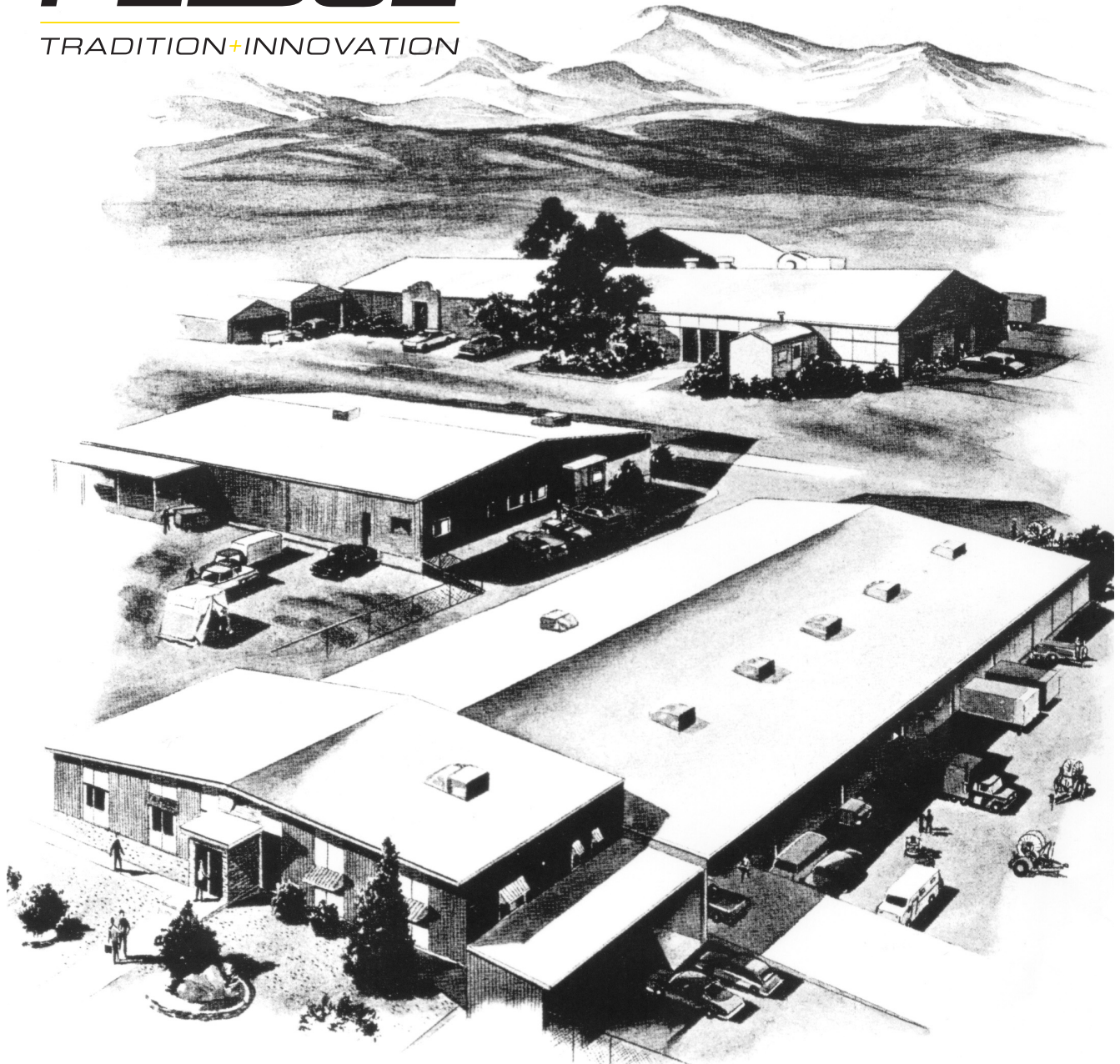

Since our inception in 1963 – the T.A. Pelsue Company has designed and manufactured high quality equipment to improve the personnel efficiency and working conditions in various underground, confined, and outdoor areas. Founded by T. Allen Pelsue, the company has established a continuing reputation for excellence in the production of fine products for a broad spectrum of industry throughout the world.

Now, in our second generation of family direction, continued commitment to innovation and quality makes Pelsue a leading source of equipment for many types of confined spaces. We specialize in safety, retrieval, fall arrest, ventilation, cable placing, splicing, and maintenance nationally and abroad. With more than 70,000 square feet of facilities available, Pelsue continues the dedication that has made us pre-eminent in this field.

Table of Contents

Section	Description	Page #
1.0	General Information	5
1.1	Quality Policy	
1.2	Pelsue Product Warranty	
2.0	Introduction & Product Information	7
2.1	Serial Number	
3.0	Configuration & Assembly	8
3.1	Parts Diagram & List	
3.2	Wiring Diagram	
4.0	Safety	11
4.1	Safety Alert Symbol	
4.2	General Safety Information	
5.0	Product Operation	13
5.1	Product Description & Capabilities	
5.2	Start-Up & Operating Procedures	

T.A. Pelsue Company

Quality Policy

OUR GOAL IS THE PURSUIT OF NEVER-ENDING IMPROVEMENT IN PRODUCT QUALITY AND BUSINESS SYSTEMS.

METHODS TO BE EMPLOYED IN ATTAINING THIS GOAL WILL INCLUDE NEW PRODUCT QUALITY PLANNING, EMPLOYEE TRAINING, AND UTILIZATION OF EMPLOYEE INVOLVEMENT GROUPS TO SOLVE PROBLEMS.

IN AN INCREASINGLY COMPETITIVE MARKETPLACE, ENSURING CUSTOMER SATISFACTION IS ONE OF THE DIFFERENTIATORS THAT SETS YOU APART FROM THE PACK AND YIELDS A COMPETITIVE ADVANTAGE.

THEREFORE, WE WILL SUPPORT TOTAL CUSTOMER SATISFACTION BY IMPLEMENTING THE **ISO 9001 QUALITY SYSTEM** AND PROVIDING THE NECESSARY ATMOSPHERE AND TRAINING TO NURTURE THIS CONCEPT THROUGHOUT OUR ORGANIZATION.

WE WILL MAKE EVERY BUSINESS DECISION AS THOUGH THE QUALITY OF THE PART OR SERVICE PROVIDED WAS DESTINED FOR OUR OWN OR OUR FAMILY'S USE. WE WILL ALWAYS THINK **QUALITY FIRST**.

EVERY T.A. PELSUE COMPANY EMPLOYEE IS EXPECTED TO COMMIT TO THIS PHILOSOPHY IN THE PERFORMANCE OF HIS OR HER DAILY TASKS.

QUALITY FIRST!

T.A. PELSUE COMPANY SENIOR MANAGEMENT TEAM

1.2 - Pelsue Product Warranty

PELSUE PORTABLE PRODUCT WARRANTY

- Pelsue products are designed and engineered to perform as stated in published specifications. Quality materials and workmanship are used in the manufacture of this product. With regular maintenance and proper care, Pelsue equipment provides many trouble free hours of operation.
- The T.A. Pelsue Company warrants to the buyer that material furnished will conform to specifications and will be free from defects in material and workmanship from the date of shipment to the original buyer, for the period listed by product description on the reverse side of this warranty statement.
- In the event of failure of any components of a Pelsue product within the warranty period, service must be pre-approved by the T.A. Pelsue Company and service must be performed by the T.A. Pelsue Company Parts and Service Department in Englewood Colorado, or at the option of T.A. Pelsue Company, service may be performed at any designated service center, which may include any authorized service center for the component manufacture.
- Damage or failure due to misuse, mishandling, or unauthorized modifications will not be covered by this warranty. Unless otherwise agreed, the T.A. Pelsue Company shall repair or replace the defective components within (30) calendar days of notice of failure. T.A. Pelsue Company's obligation hereunder, shall be limited to the repair or replacement of the product or component as set forth above, and shall not include any liability whatsoever for damages caused by such failure, including but not limited to consequential or incidental damages flowing from use or lack of use of product.
- Any replacement, repair, modification, installation or other service performed by the T.A. Pelsue Company shall be warranted by the remainder of the unexpired period of the warranty, or for a period of (90) calendar days, whichever is longer.
- All materials or parts returned for credit or warranty shall be returned only with prior approval, and will be subject to factory inspection before credit is allowed. Parts claimed defective will be replaced upon request and will be invoiced as purchased, subject to credit when the parts claimed to be defective have been received and examined by the factory.
- This warranty is expressly in lieu of all other warranties expressed or implied, including any warranties of merchantability or warranties of fitness for any particular use and all other obligations or liabilities in connection with the sale of this equipment.

<u>Product Description</u>	<u>Warranty Coverage*</u>
• Blowers.....	1 year
• Heaters.....	1 year
• Blower Hoses/Ducts.....	3 months
• Pel-Cans and Caddys.....	1 year
• Hose Adapters.....	1 year
• Manhole Shields & Manhole Guards.....	1 year
• Pel-Brite Work Lights.....	6 months
• Planks and Plank Supports.....	6 months
• Duct Rodders and Accessories.....	6 months
• Submersible Pumps.....	6 months
• Discharge and Suction Hoses for Pumps.....	3 months
• Wheel Chocks.....	1 year

*From date of shipment to original buyer.

T.A. Pelsue Company, 2500 South Tejon Street, Englewood, Colorado 80110, 800-525-8460

2.0 - Introduction & Product Information

Congratulations on your choice of a **Pelsue Model #1000 Centrifugal Blower** to compliment your confined space ventilation operation. This equipment has been designed and manufactured to exceed confined space requirements and regulations in order to meet the needs of the discriminating operator for efficiency and safety during confined space entry operations.

Safe, efficient and trouble-free operation and maintenance of the system requires that anyone who will be operating, maintaining, or inspecting the equipment, read, understand and follow all the operation, safety, maintenance, and inspection instructions contained within this manual. This manual covers the Pelsue Model #1000 Centrifugal Blower. Use the Table of Contents as a guide to find specific information.

Keep this manual available for future reference if required, and as a tool in the training of new operators.

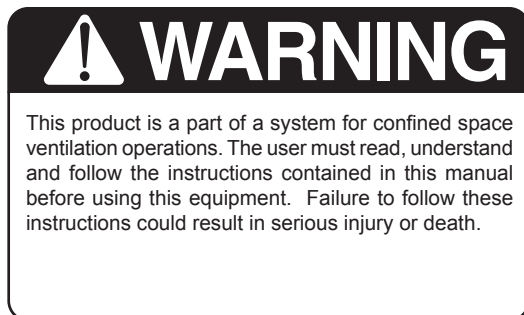

2.1 - Serial Number

Product Serial Number

Always give your dealer the serial number of your Pelsue confined space ventilator product when ordering parts or requesting service or other information.

The specification & rating decal is permanently embossed with a serial number. The rating decal is located at the top of the housing of the centrifugal blower as shown in *Fig. 2a*. The specification & rating decal will appear as shown to the right in *Fig. 2b*. A space has been provided below for the recording of the serial number for future reference.

MODEL: **#1000**

Serial Number : _____

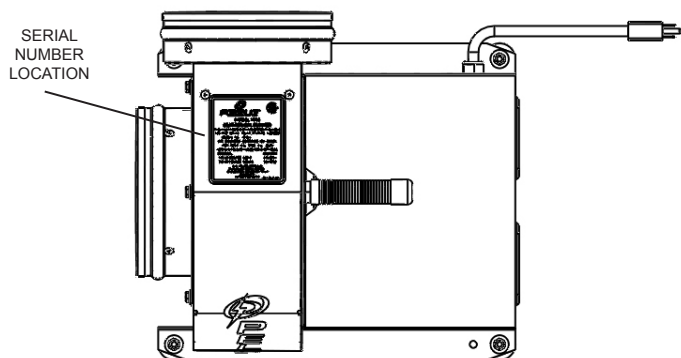

Figure 2a: Serial Number Location

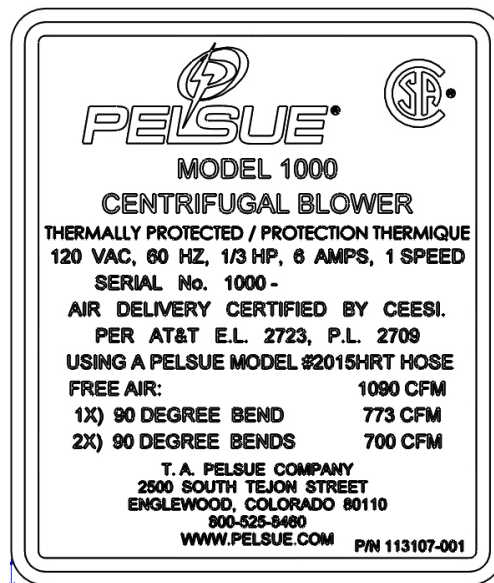

Figure 2b: #1000 Serial Number Decal

3.0 - Configuration & Assembly

Upon initial receipt of the Model #1000 Centrifugal Blower, inspect the packaging for any evidence that the product may have been damaged in shipment. While unpacking the product, inspect all of the components for damage. If damage to any of the components is discovered, Alert the shipping carrier immediately of the damage to the shipment.

3.1 Parts Diagram & List

Refer to the following parts breakdown diagram (Figure #3.1a) and the accompanying parts list (Table #3.1a) for identification of parts in the event replacements become necessary. The parts list table displays applicable part numbers, descriptions, and quantity per assembly.

* Replacement parts can be ordered from the T.A. Pelsue Company at 800-525-8460.

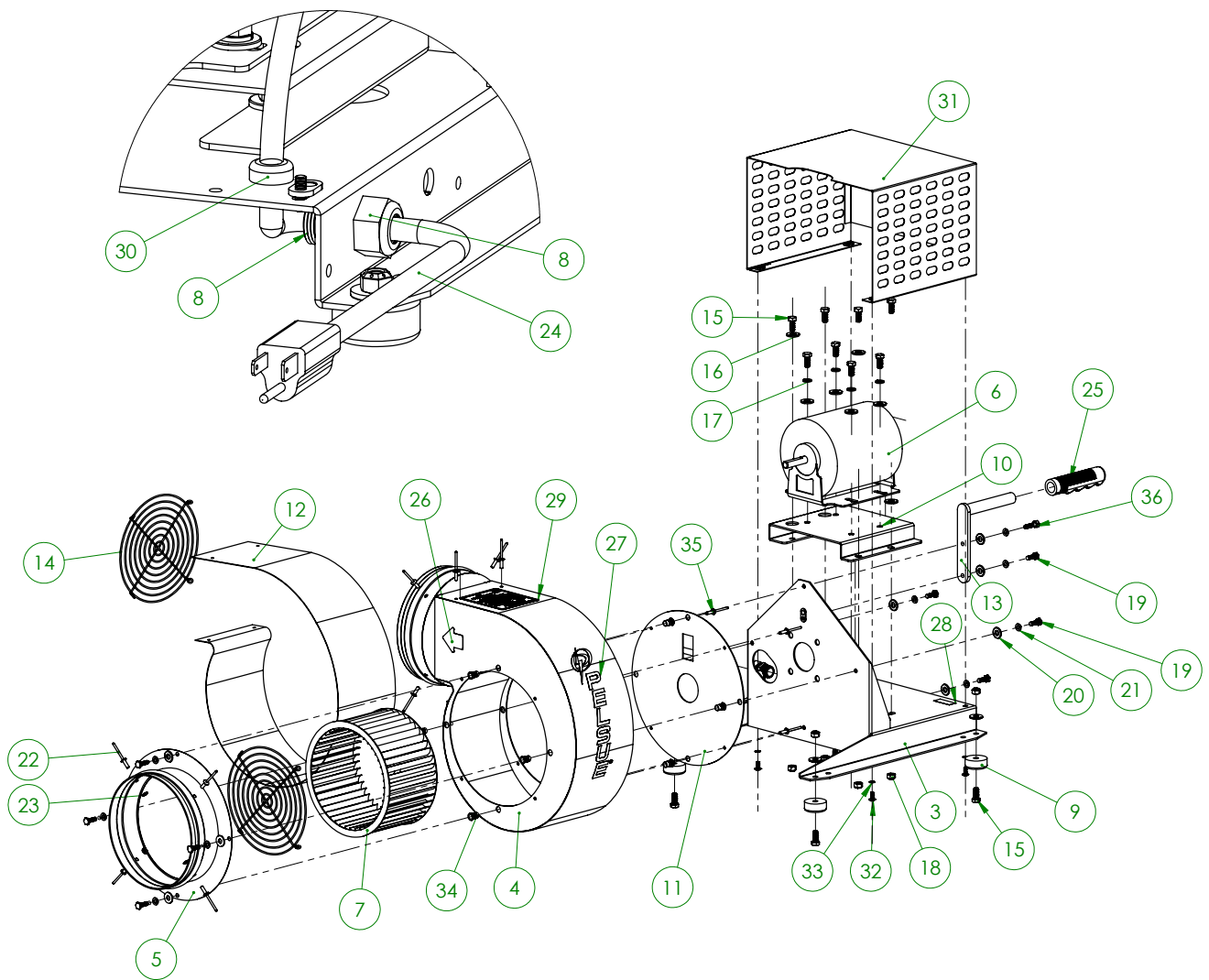

Figure 3.1a: #1000
Parts Diagram

3.1 Parts Diagram & List (continued)

ITEM NUMBER	PART NUMBER	DESCRIPTION	QUANTITY
3	124389-Y13	WELDMENT - 12 GA STEEL, BLOWER BASE	1
4	124343-001	WELDMENT - CENTRIFUGAL BLOWER HOUSING	1
5	124355-001	WELDMENT - SUCTION ADAPTER, RIVET ON GRILLE	1
6	118247-001	MOTOR - 1/3 HP, 115 VAC, 60 HZ, 1 SPEED, 48 FRAME	1
7	44H-150300	WHEEL - BLOWER, STEEL, .5" BORE, 7.91" OD 2200 RPM	1
8	100405-004	STRAIN REL - 1/2" HUB, 0.250"- 0.375" DIAM.	1
9	100188-002	FOOT - RUBBER, 1-1/2" OD W/REC WASHER	4
10	124398-048	SPACER - 48 FRAME MOTOR	1
11	124344-001	ADAPTER PANEL - MOUNTING PATTERN FOR MOTORS	1
12	124347-791	INSERT - CUT-OFF, FOR 7.91" BLOWER WHEEL	1
13	102440-001	HANDLE - 1000 SERIES BLOWERS	1
14	112298-001	GRILLE - INTAKE/OUTLET, 13 GA STEEL WIRE, BLACK	2
15	100157-007	SCREW - HEX HD, 5/16-18 UNC X 3/4" LONG, PLATED	12
16	100050-010	WASHER - FLAT, 5/16" TYPE A, W, PLATED	16
17	100121-010	WASHER - LOCK, 5/16", HELICAL SPRING, PLATED	4
18	107942-001	NUT - STOVER, 5/16"-18 UNC, GRADE 5	8
19	101427-002	SCREW - CAP, HEX HEAD, 1/4"-20 UNC X 3/4"	8
20	100050-009	WASHER - FLAT, 1/4 IN, TYPE A, W, PLATED	9
21	100121-009	WASHER - LOCK, 1/4 IN, HELICAL SPG, PLATED	9
22	118519-001	RIVET - STAVEX, BLIND FLANGE DOME, BLACK, 0.188"	12
23	104151-001	WASHER - RIVET BACK UP, 7/32" ID X 7/16" OD, SS	12
24	26E-005700	CORDSET - W/MOLDED PLUG 16/3 SJTOW RATED	1
25	124624-001	GRIP - SLIDE-ON, ROUND FINGER GRIP, FITS 3/4" OD	1
26	111837-001	DECAL - DIRECTIONAL ARROW, BLACK	2
27	121529-001	DECAL - "PELSUE" VERTICAL WITH "P" LOGO	1
28	900306-001	DECAL - "INSPECTED BY - DATE", ADHESIVE BACK	1
29	113107-001	DECAL - IDENTIFICATION, RATING & SERIAL #, MODEL #1000	1
30	62E-011200	GROMMET - RUBBER, 3/8" ID X 3/4" OD	1
31	124943-001	WELDMENT - CENTRIFUGAL MOTOR COVER, BOLT-ON	1
32	111841-002	SCREW - MACHINE TRUSS HEAD, 10-24 UNC X 1/2" LG, BLK	4
33	68N-004300	WASHER - LOCK, INTERNAL TOOTH, #10, PLATED	4
34	120386-001	NUTSERT - THIN SHEET, 1/4-20 UNC, CRIMP-IN STYLE	8
35	118518-001	RIVET - STAVEX, BLIND FLANGE DOME, BLACK, 0.188" DIA	4
36	100604-010	SCREW - CAP, HEX HD, 1/4-20 UNC X 1" PLATED, GRADE 5	1

Table 3.1a: #1000
Parts List

3.2 Wiring Diagram

Shown below in Figure 3.2a, is a wiring diagram of the motor and the cordset.

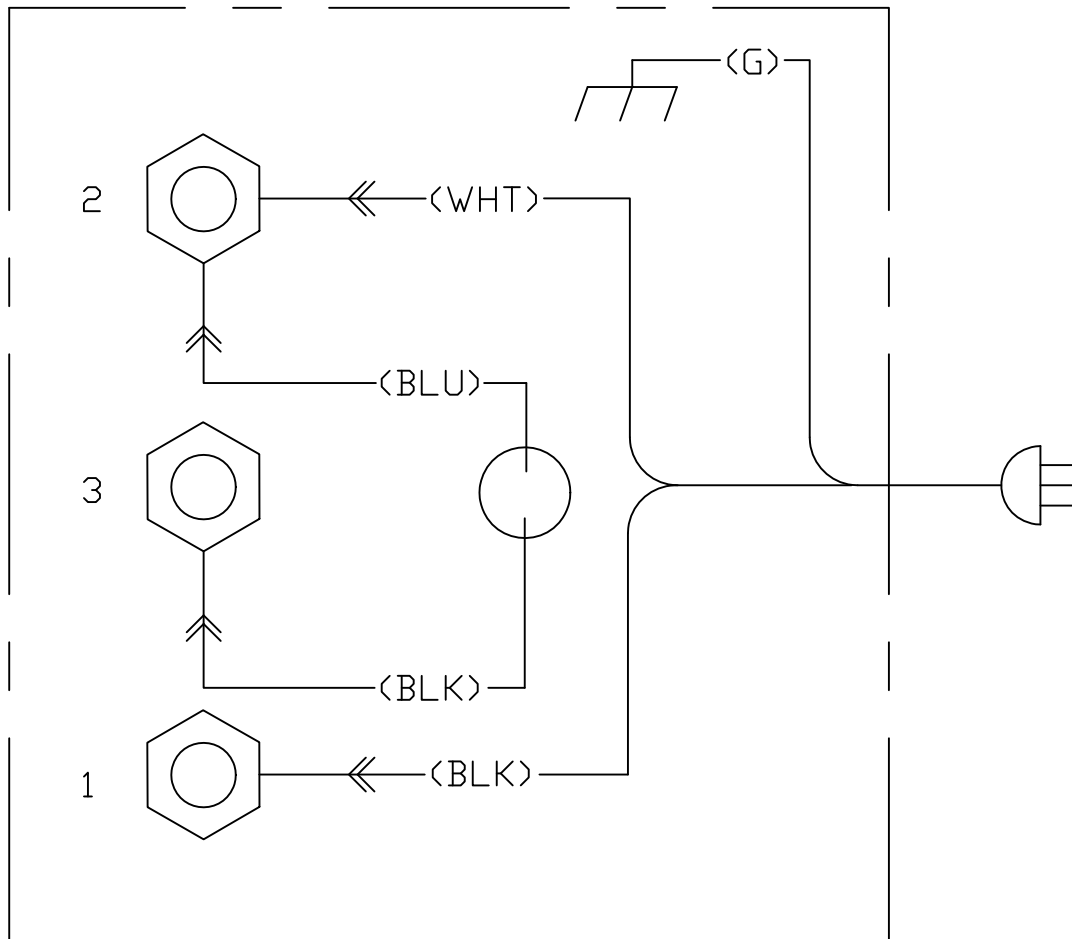

Figure 3.2a: #1000
Wiring Diagram

The following section will address the safety precautions which must be adhered to when working with Pelsue confined Space Ventilation equipment such as the #1000 Centrifugal Blower. Any user must familiarize themselves with the information in this section before utilizing the equipment.

SIGNAL WORDS:

Note the use of the signal words **DANGER**, **WARNING** and **CAUTION** with the safety messages. The appropriate signal word for each message has been selected using the following guidelines:

- DANGER-** Indicates an imminently hazardous situation that, if not avoided, will result in death or serious injury. This signal word is to be limited to the most extreme situations or for hidden or unseen hazards.
- WARNING-** Indicates a potentially hazardous situation that, if not avoided, could result in death or serious injury and includes obvious and hidden hazards. It may also be used to alert against unsafe practices.
- CAUTION-** Indicates a potentially hazardous situation that, if not avoided, may result in minor or moderate injury. It may also be used to alert against unsafe practices.

You are responsible for the safe operation of your Pelsue #1000 Centrifugal Blower. You must ensure that anyone who will operate or work around the equipment be familiar with confined space ventilation procedures. This manual will take you step-by-step through the workings and capabilities of the #1000 Centrifugal Blower and alert you to good safety and operating practices while using the system.

Remember, you are the key to safety. Good safety practices not only protect you but also the people around you. Make these practices a working part of your safety program. Be certain that everyone operating in or around a confined space is familiar with the procedures recommended and follows safety precautions. Remember, most accidents can be prevented. Do not risk injury or death by ignoring good safety practices.

- The most important safety device on this equipment is a safe operator. It is the operator's responsibility to read and understand all of the safety and operating instructions presented within this manual and to follow them. Most accidents can be avoided.
- A person must understand the operation of this equipment and be trained in its usage before operating the equipment. An untrained operator exposes himself and others to possible serious injury or death.
- Do not modify the equipment in any way. Unauthorized modification may impair the function and/or safety and could affect the life of the equipment.
- Think SAFETY! Work SAFELY!

4.1 - Safety Alert Symbol

SAFETY ALERT SYMBOL

This Safety Alert symbol means **ATTENTION! BECOME ALERT! YOUR SAFETY IS INVOLVED!**

The Safety Alert symbol identifies important safety messages on your Pelsue Confined Space Product and in the manual. When you see this symbol, be alert to the possibility of personal injury or death. Follow the instruction in the safety message.



Why is this symbol important to you?

- 3 BIG Reasons:**
- Accidents Disable and Kill.**
 - Accidents Cost You Money.**
 - Accidents Can Be Avoided.**

4.2 - General Safety Information

Safety Precautions:

It is necessary to follow these safety precautions, each time, prior to using the product.

The Safety Precautions are not limited to, but must include the following items;

1. Do not use the blower for anything other than its intended use.
2. Do not wear loose clothing that can become entangled in operating machinery. Do not operate the blower without inlet or outlet screen guards in place.
3. Do not place fingers or any other object through inlet or outlet screens.
4. Always operate the blower from a properly grounded receptacle.
5. Never handle energized power cords with wet hands.
6. Never let extension cords or plug connections lay in water. Locate the blower so that it cannot fall into water inadvertently.
7. Never use cords with frayed , cut, or brittle insulation. Check the cord for sound connections to the ground fault interrupter receptacle.
8. Never use this blower in an explosive environment.
9. Ensure that toxic fumes are not blown into a confined space.
10. Unattended use of equipment is not recommended.



! CAUTION ! - Be sure the blower is disconnected from the power source before doing any maintenance or repair work on the blower.

! CAUTION ! - Check all power cords for cuts, frayed ends, or brittle insulation. See parts list for replacement cord part number.

! CAUTION ! - The user must ensure that the blower is located where it cannot fall into water inadvertently and the extension cords or plug connections do not lay in water.

5.0 - Product Operation

The following section will address the capabilities and the general operation of the Pelsue Model #1000 Centrifugal Blower. The instructions contained within this section should be adhered to each and every time the product is used. Any person tasked with installing or operating this piece of equipment should be familiar with these procedures.

5.1 - Product Description & Capabilities

The Pelsue Model #1000 Centrifugal Blower is built with a rugged steel housing and internal steel and/or aluminum components. The Pelsue #1000 Centrifugal Blower is specifically designed for confined space applications. All specifications, instructions, and procedures provided within this manual or upon Pelsue Specification Documents are based upon and only valid for usage with Pelsue accessories. The T.A. Pelsue Company can not verify equipment safety and/or compliance when utilized with anything other than Pelsue approved confined space accessories.

Centrifugal Blower - #1000

General Specifications

- Weight - 35 lbs.
- Height - 16-5/8"
- Width - 16-1/2"
- Length - 18-1/8"

Features:

- Low Maintenance
- Specifically designed to provide a completely portable source of fresh air

Materials & Construction

- Main Structure: - Steel
- Hardware - Plated Steel

Model Specifications & Performance - #1000

- Voltage 120VAC, 60Hz
- Amperage 6.2
- H.P. 1/3 (.248kW)
- Free Air 1090 CFM (30.9 m3/min)
- One 90° Bend 773 CFM (21.9 m3/min)
- Two 90° Bends 700 CFM (19.8 m3/min)

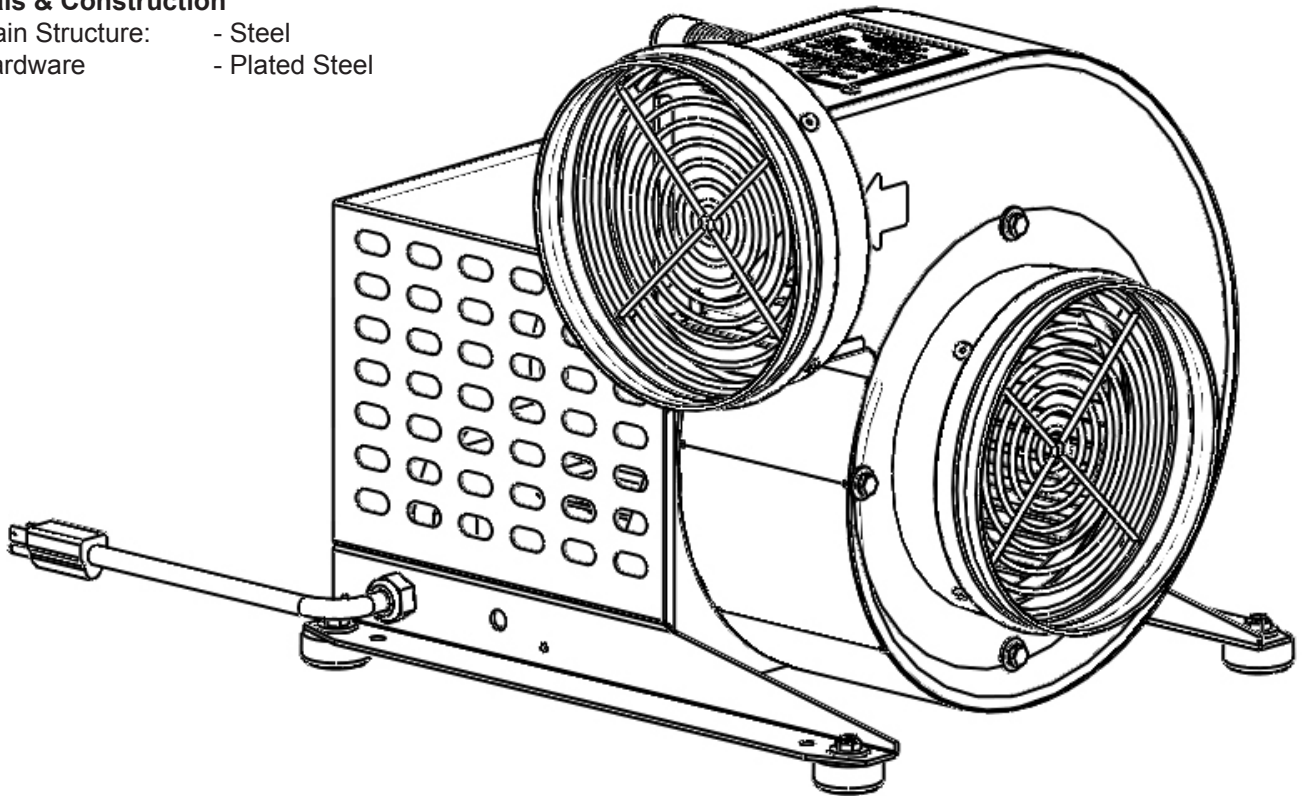

Figure #5.1a: #1000
Centrifugal Blower

Additional Requirements & Notes

- The #1000 Centrifugal Blower is a single-speed blower.

5.2 - Start-Up & Operating Procedures

Prior to Operation, the #1000 Centrifugal Blower should be configured and prepared according to the following guidelines.

1. Pre-Operation Inspection:

It is necessary to perform a visual inspection, each time, prior to using the product. If deficiencies are found, remove the product from service and contact the T.A. Pelsue Company regarding repair. The following checklist coupled with *Figure #5.2a* should be used as a guide to determine whether the equipment is in good operating condition prior to usage. Equipment that is not in good condition can endanger the safety of the entrant and attendant during use.

The Pre-Operation Visual Inspection is not limited to, but must include the following items;

- a. Check the blower inlet and outlet grilles for obstructions.
- b. Remove any objects around the immediate area that could be sucked into the blower.
- c. The cordset is properly attached to the blower.
- d. The rubber feet are attached.
- e. The motor cover is secured to the base.

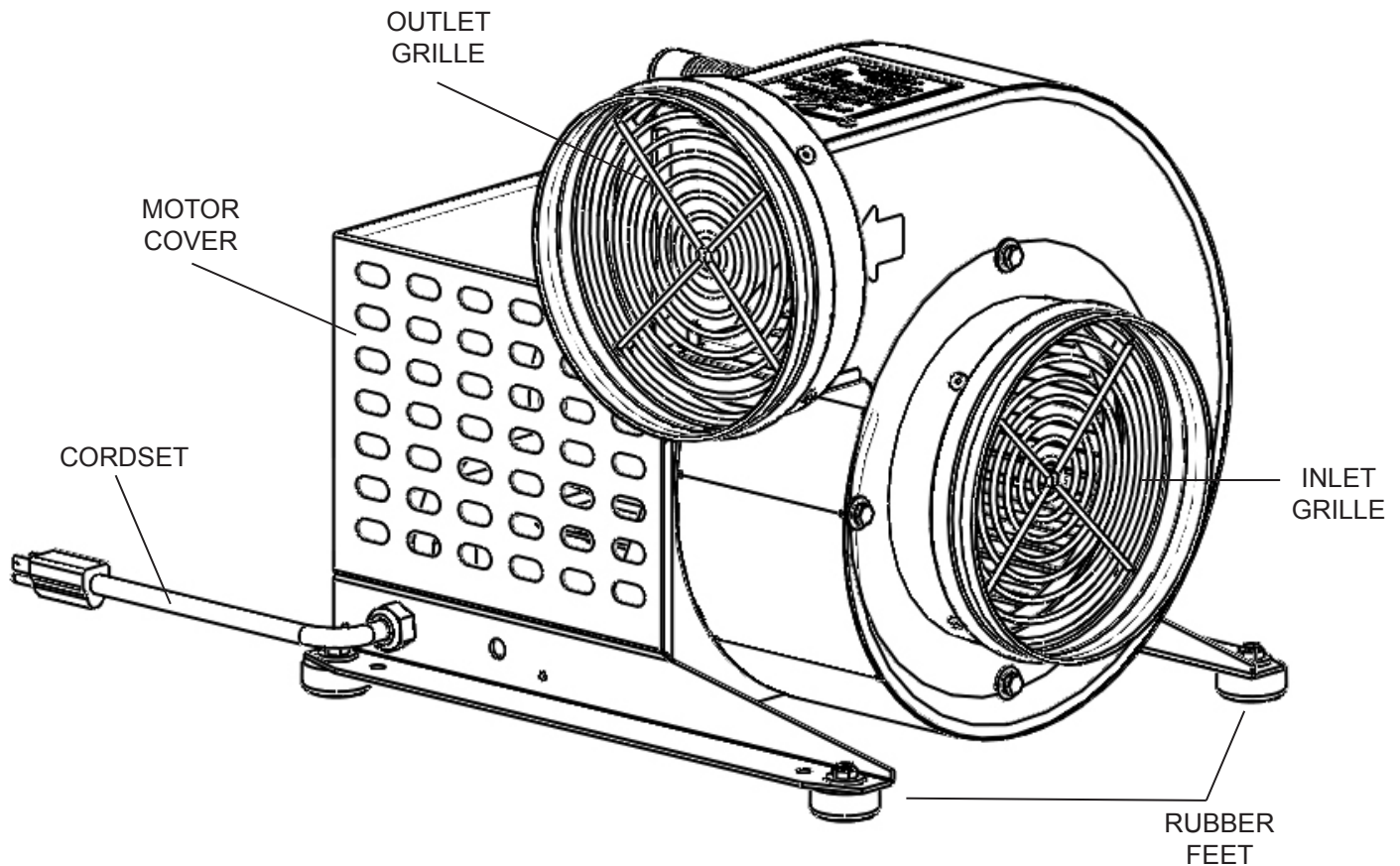

Figure #5.2a: #1000 Centrifugal Blower
Pre-Operation Inspection Points

5.2 - Start-Up & Operating Procedures (continued)

2. Setup of 1000 Centrifugal Blower:

Choose a location where installation will provide suitable proximity to the work area yet minimize obstructions during use and in the event a rescue is necessary. Once a location is chosen;

- a. Blower should be placed 1.5 meters upwind where possible, from the confined space, and have its inlet pointed into the wind. This will reduce the chance of contamination being blown into the confined space.
(Refer to Fig. #5.2b)
- b. Plug the blower power cord to a properly grounded receptacle.
- c. Extend and place the blower hose as required.
- d. When blower operation is no longer required, unplug the power cord.

Important Notes:

- During confined space entry operations, it should not be assumed that the ventilator will maintain the air inside the confined space at a safe condition. When the ventilator is in use, the air inside the confined space should be monitored continuously for the presence of poisonous gases and/or toxic fumes.
- Ensure that the blower provides positive airflow the entire time during usage. The Centrifugal blower can be used with an accessory Air Flow Alarm (Pelsue Model #FLO-CHEK) that will alert the entrants when and if positive ventilation is lost during operation.

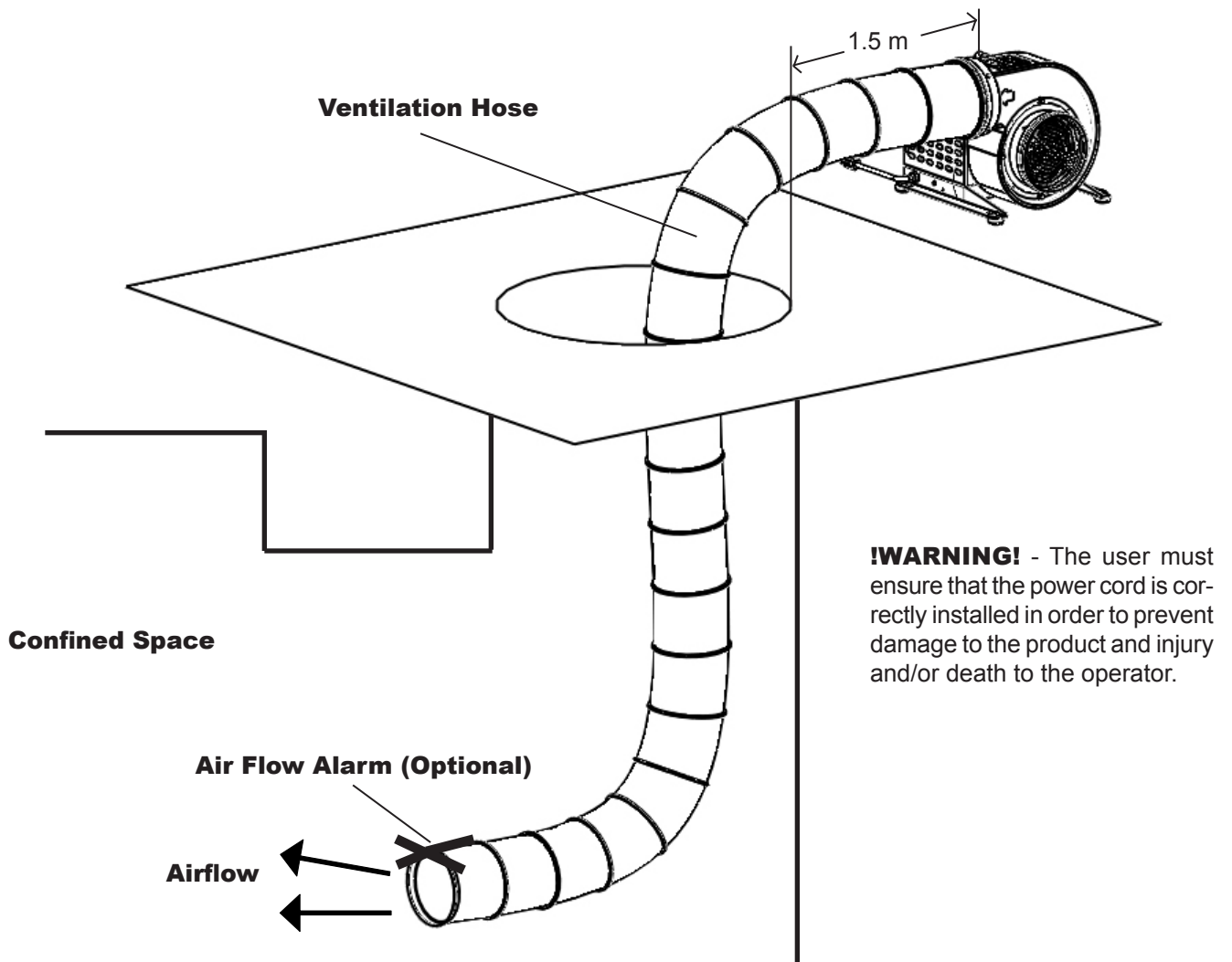

!WARNING! - The user must ensure that the power cord is correctly installed in order to prevent damage to the product and injury and/or death to the operator.

Figure #5.2b: Centrifugal Blower Setup in Confined Space



T.A. Pelsue Company

2500 South Tejon Street, Englewood, Colorado, USA 80110
Toll free 800-525-8460 or 303-936-7432 Fax. 303-934-5581
Internet: www.pelsue.com Email: sales@pelsue.com