



Product Specifications

Model: LG5A Manhole Guard Retrieval System

The Pelsue #LG5A system is a simple to use, lightweight, safety product for usage around underfoot manways. The LG5A system is composed of two major parts, the first of which is a compact folding guard fence fully equipped with safety chains that enables the barricading of open manways when entry is necessary. The second major component of the system is a four-legged lightweight, foldable structure that inserts into the tops of the guard section's four corner posts. The four-legged section can be secured to the guard via 4 highly durable rubber t-handle latches located at the ends of each of the 4 legs. This safely keeps the upper section secured to the guard section to prevent the system from disengaging from one another or if movement of the system is needed while the upper and lower sections are desired to remain attached. The upper assembly has several features which allow the assembled guard and upper section to be utilized as a certified overhead lifting device and also provides compliant overhead anchorage for the attachment of personal fall arrest systems. The LG5A system is truly a single source, do-it-all product for safe and compliant confined space entry operations

General Specifications:

The #LG5A is designed and tested to be used in 2 General Applications:

1. As part of a confined space entry operation to be utilized as a personnel lifting, lowering, and retrieval device as required in OSHA 1910.146 & ANSI Z117.1.

Man Rated Load Capacity..... Single user of 350 LBS. (159 KG.) Maximum Weight

2. As an anchorage for a personal fall arrest system as per OSHA 1926 & ANSI A10.14.

!Warning! The LG5A system must be operated in accordance with the product manual and all labels in order to retain the stated compliance & ratings. A fall arrest force limiting device must be utilized when employed as a complete fall arrest system.

Materials & Construction:

Guard Assembly (#LG5-GA):

- Main Structure.....6000 Series Aluminum
- Chains.....Coil, Plated Steel

Upper Assembly (#LG5-TA):

- Front legsCarbon Steel
- Rear legs.....Structural Aluminum
- Apex HubPlate Aluminum
- Chain.....Coil, Plated Steel
- HardwareGrade 5 & Grade 8 (plated)

Finish: Safety Yellow Powdercoat (except where plated)

Weight:

- LG5-GA (Guard).....35.5 lbs. (16.1 kg)
- LG5-TA (Upper).....41.8 lbs. (19.0 kg)
- LG5A (Total System).....77.3 lbs. (33.1 kg)
- 2.25 lbs. - Weight of Pulley & Carabiner



2500 S. Tejon St.
Englewood, CO 80110
Ph: 1-800-525-8460, (303) 936-7432
Fax: (303)934-5581
Web: www.pelsue.com E-mail: sales@pelsue.com

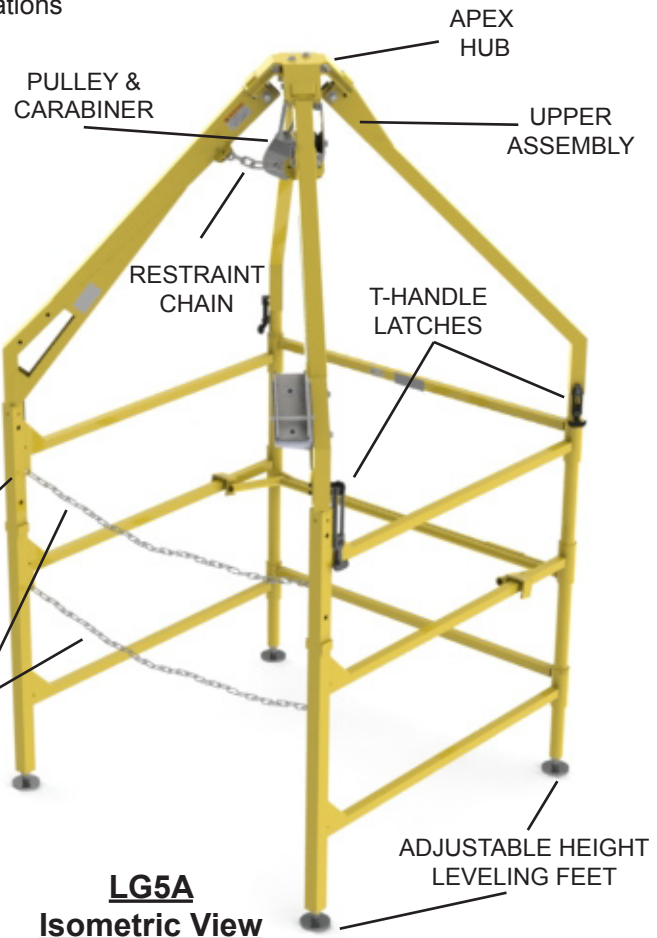

LG5A
Isometric View

Other Features:

- Easily assembles over most manways for safe and secure lifting & retrieval of personnel
- Several options for winch mounting make the system compatible with many winch and fall arrest devices.
- Constructed primarily of lightweight & Corrosion-resistant powder coated aluminum.
- System incorporates an integral, compliant overhead anchor point for fall arrest system anchorage.
- The entire system splits into two folding segments for easy transport & storage.
- Latches secure upper assembly to guard assembly
- System also comes with rubber feet for no slippage on ground surface (Replaces leveling feet)



Product Specifications

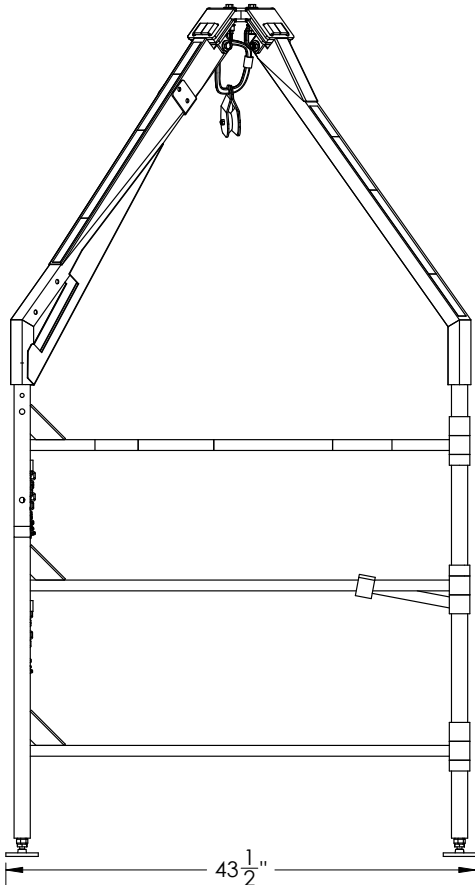

SIDE VIEW

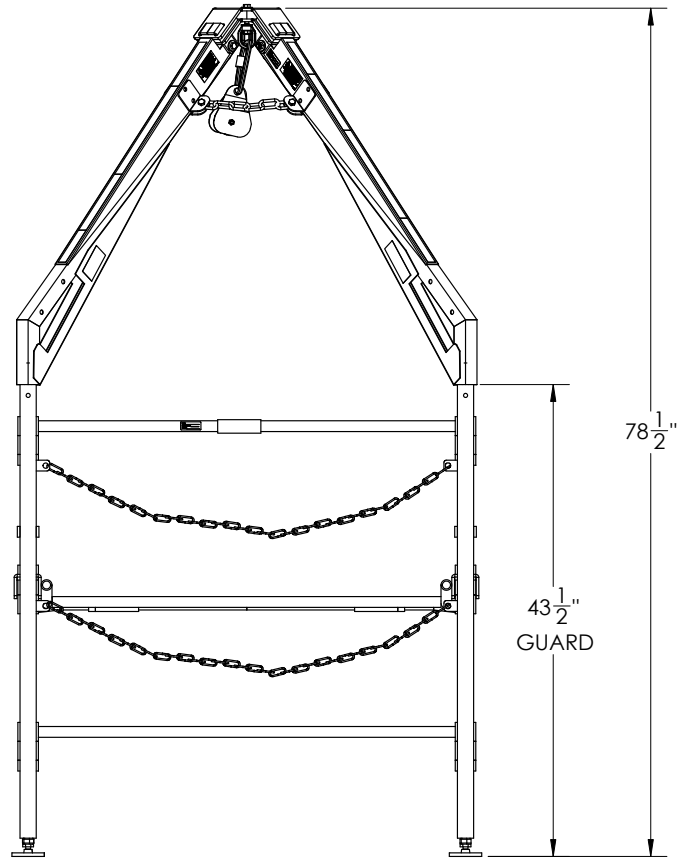

FRONT VIEW

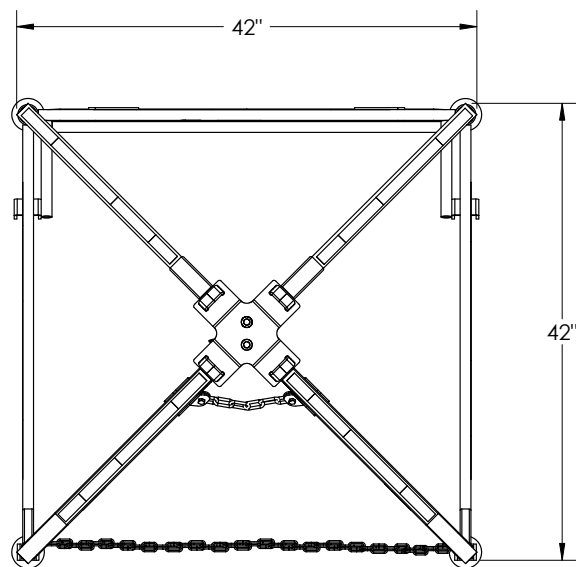

TOP VIEW



2500 S. Tejon St.

Englewood, CO 80110

Ph: 1-800-525-8460, (303) 936-7432

Fax: (303)934-5581

Web: www.pelsue.com E-mail: sales@pelsue.com