

2-Color Display



Digital Flow Switch

Applicable fluid **Dry air, N₂**

New

3-Screen Display

Digital Flow Monitor

Allows for the monitoring of remote lines

PFG300 Series **p.24**



Wide range of flow measurement with one product

Flow ratio*1 **100:1**

*1 Rated flow ratio is 10 : 1 for the current PF2A.

Smallest settable increment: **1 L/min**

Current PF2A: 5 L/min (200 L: 2 L/min)

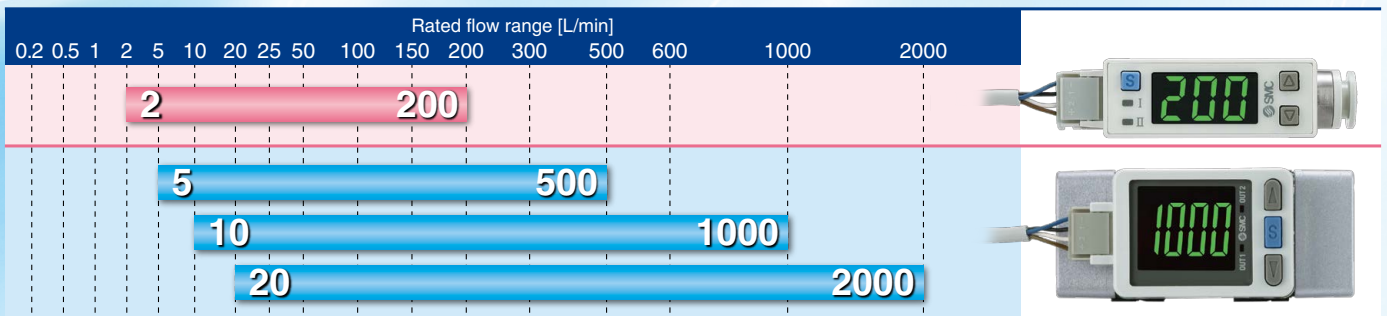

Compact, Space saving

Compared with the current PF2A

Weight **Approx. 76% reduction**
290 g → 70 g

Mounting space **Approx. 81% reduction**



Compared with the current PF2A

Weight **Approx. 66% reduction**
290 g → 100 g

Mounting space **Approx. 67% reduction**

500 L/1000 L/
2000 L type

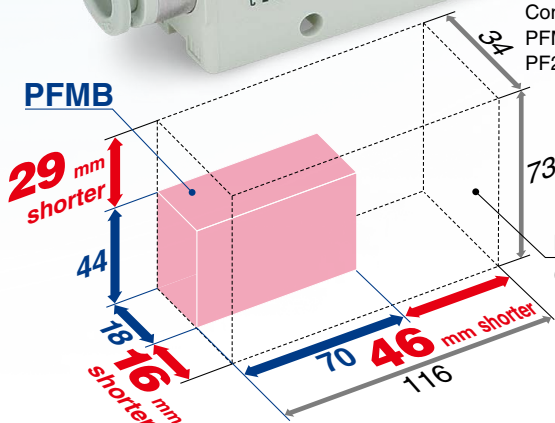

Compared with the PFMB7201 and PF2A721-03

PF2A series (Current model)

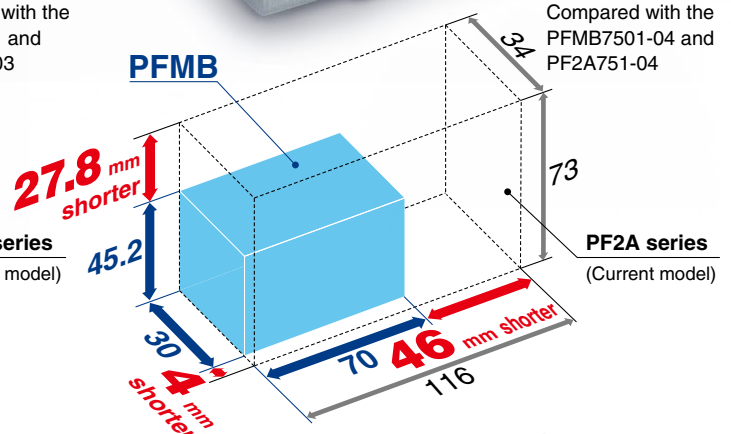

Compared with the PFMB7501-04 and PF2A751-04

PF2A series (Current model)

PFMB Series



CAT.ES100-95C

2-Color Display Digital Flow Switch

Flow adjustment valve is integrated.

500 L/1000 L/2000 L type

200 L type

Reduces piping installation work and space requirements. Special design provides smooth adjustment to match needle rotations.

Flow adjustment valve

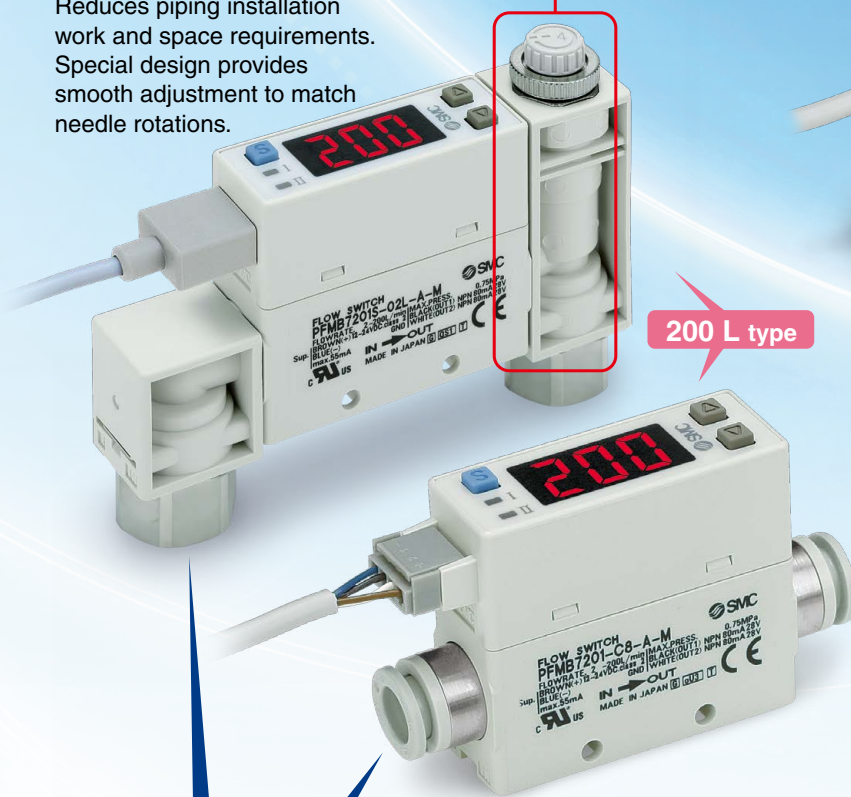

200 L type



Response time

Can be selected from

50 ms (0.05 s) / 0.1 s / 0.5 s / 1.0 s / 2.0 s

Response time can be set depending on application.

Grease-free

Piping variations

200 L type

Straight

One-touch fitting $\varnothing 8$

Female thread Rc, NPT, G 1/4

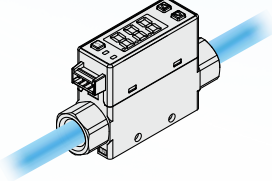
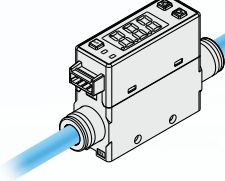

Bottom

One-touch fitting $\varnothing 8$

Female thread Rc, NPT, G 1/4

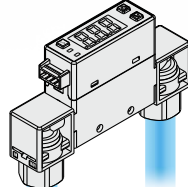
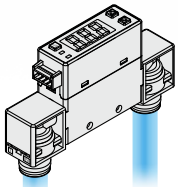

Reversible display

When the switch is used upside down, the orientation of the display can be rotated to make it easier to read.

When display is upside down.

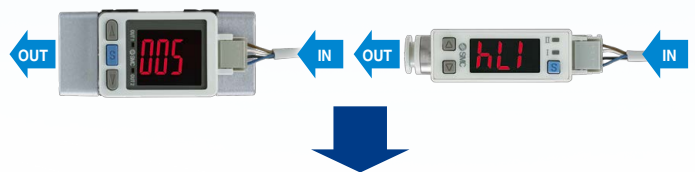

With a reversible display function (Can be set with the reversible display mode.)



* For the straight section of piping, refer to "IN Side Straight Piping Length and Accuracy" on page 12.

Functions (Refer to pages 30 and 31 for details.)

- Output operation
- Display color
- Reference condition
- Display mode
- Response time
- Display OFF mode
- Setting of security code
- External input function
- Forced output function
- Accumulated value hold
- Peak/Bottom value display
- Keylock function
- Analog output free range function
- Reversible display mode
- Reset to the default settings
- Error display function

Bypass structure

Bypass structure with protruding part at the main piping, reduces the contact of moist air with the sensor, reducing degradation of the sensor and maintaining accuracy.

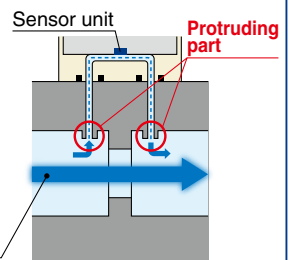

Digital flow switch to save energy!

Flow control is necessary for promoting energy saving in any application. Saving energy starts from numerical control of the flow consumption of equipment and lines and clarification of the purpose and effect.

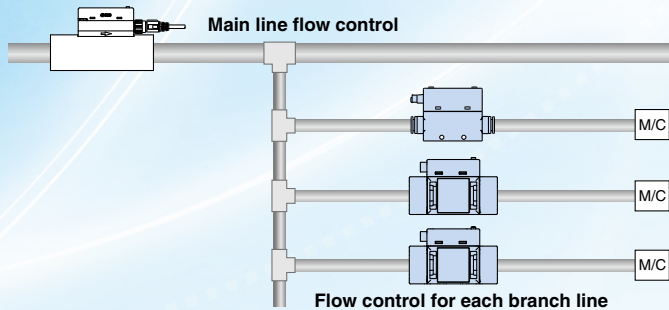
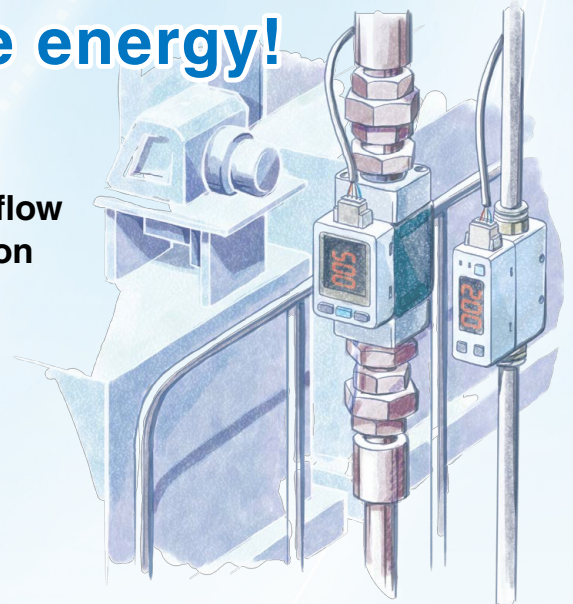

- Digital display allows **visualization of flow rate**.
- **2-color** display, Improved visibility
- **Remote control** is possible with accumulated pulse.

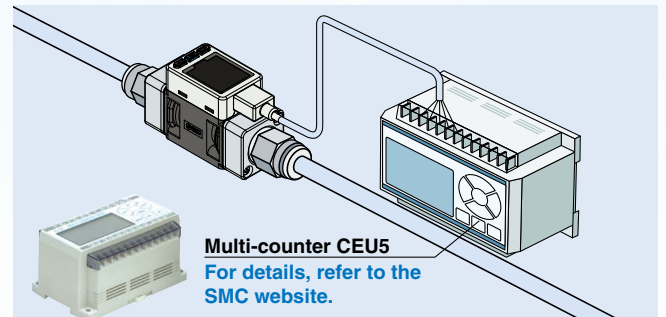

Applications

- Control of purge air flow of ionizer
- Flow control of the air for spray painting
- Flow control of N₂ gas to prevent lead frame oxidation
- N₂ blow prevents distortion of camera image due to air turbulence.
- Accumulated indication shows the operating flow rate or residual amount (of N₂ etc.) in a gas cylinder.

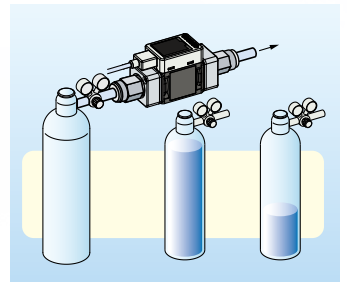
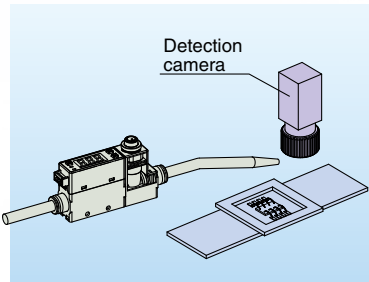
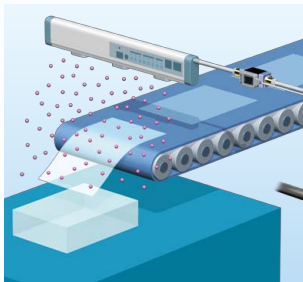

Mounting

200 L type

Through-hole

DIN rail

Bracket

Panel mount

500 L/1000 L/2000 L type

Bracket

Example of recommended pneumatic circuit
Air quality in the product specification can be satisfied by using this pneumatic circuit.

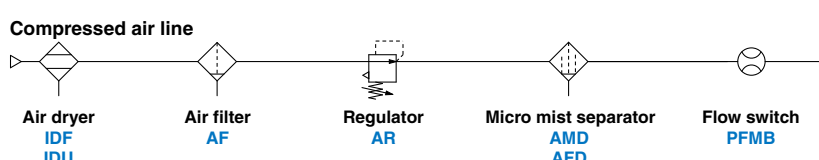

3-Screen Display Digital Flow Monitor

PFG300 Series p. 24



Allows for the Monitoring of Remote Lines

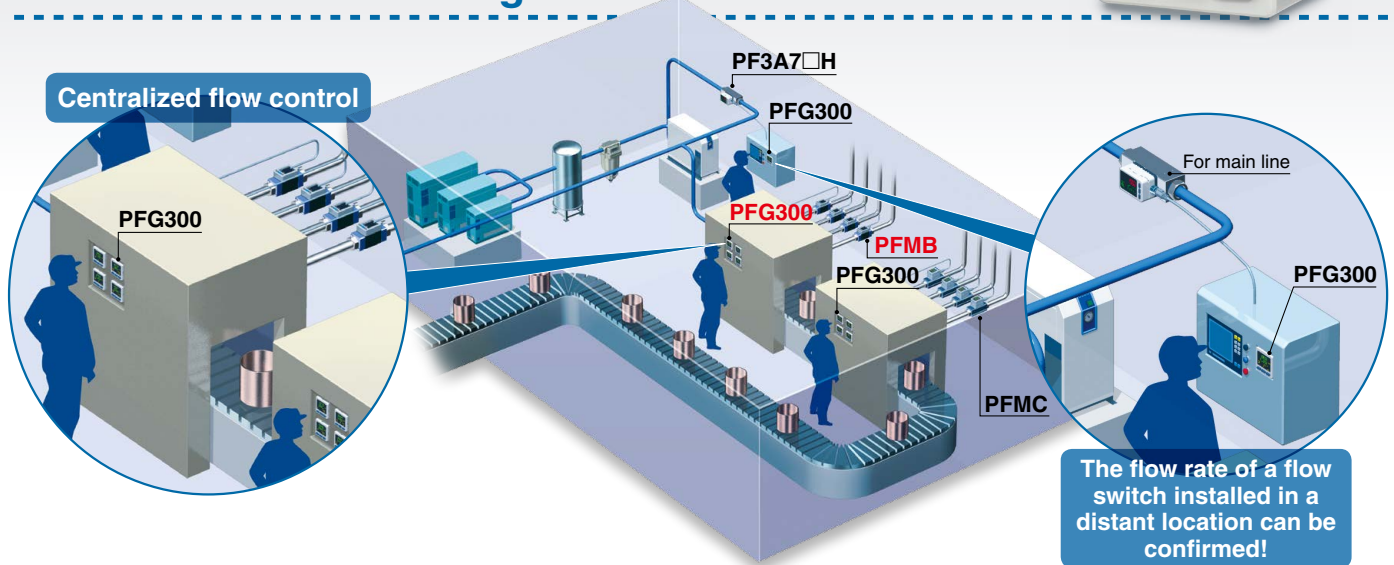

Visualization of Settings

The sub screen (label) shows the item to be set.

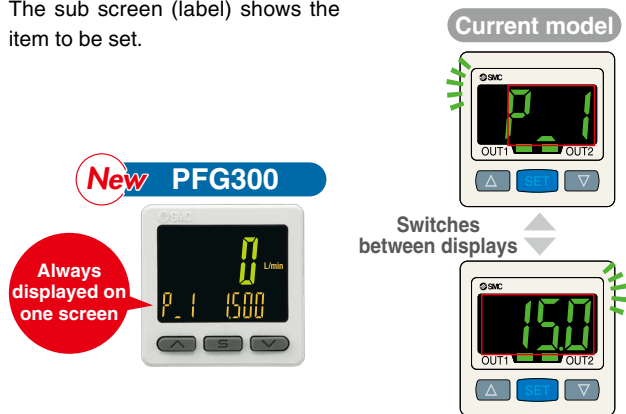

Mode Examples	Hysteresis mode					
	Normal output	Set value (Threshold value)	Reversed output	Set value (Threshold value)	Hysteresis	Set hysteresis value
	P.L	1500	n.L	1500	H.L	150
Mode Examples	Window comparator mode					
	Normal output/Lo side	Set value (Threshold value)	Normal output/Hi side	Set value (Threshold value)		
	P.L	900	P.H	1800		
	Reversed output/Lo side	Set value (Threshold value)	Reversed output/Hi side	Set value (Threshold value)		
	n.L	900	n.H	1800		

Easy Screen Switching

It is possible to change the settings while checking the measured value.

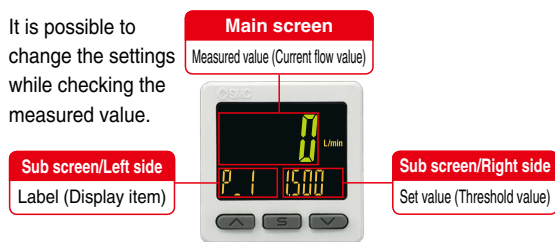

The sub screen can be switched by pressing the up/down buttons.

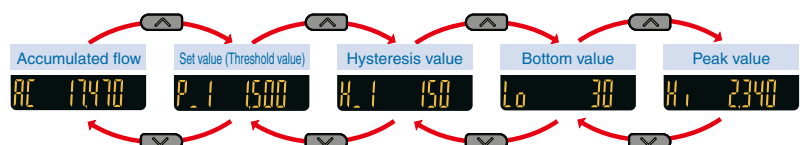

* Either "Input of line name" or "Display OFF" can be added via the function settings.

Simple 3-Step Setting

When the S button is pressed and the set value (P_1) is being displayed, the set value (threshold value) can be set. When the S button is pressed and the hysteresis (H_1) is being displayed, the hysteresis value can be set.

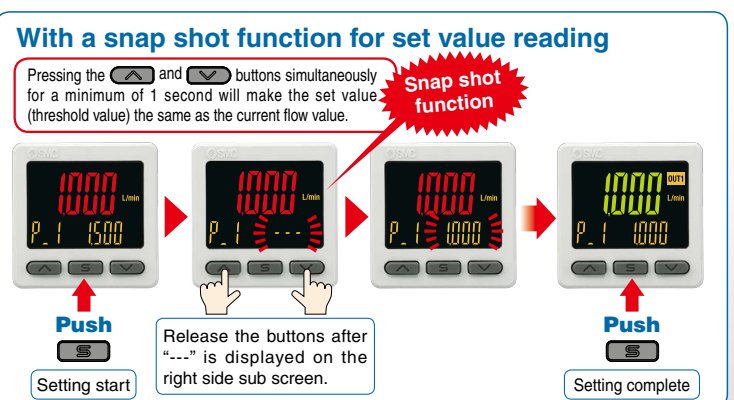
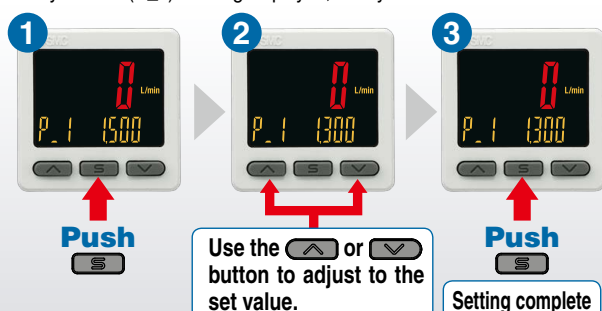

NPN/PNP Switch Function

The number of stock items can be reduced.



Analog output of 0 to 10 V is also available.

Voltage output	1 to 5 V	Switchable
	0 to 10 V	
Current output	4 to 20 mA	Fixed

Convenient Functions

● Copy function

The settings of the master monitor can be copied to the slave monitors.

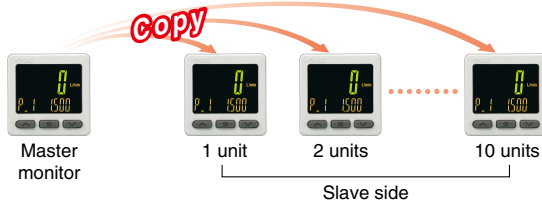

● Security code

The key locking function keeps unauthorized persons from tampering with the settings.

● Power saving mode

Power consumption is reduced by turning off the monitor.

Current consumption*1	Reduction rate*2
25 mA or less	Approx. 50% reduction

*1 During normal operation *2 In power saving mode

● External input function

The accumulated value, peak value, and bottom value can be reset remotely.

Functions (▶ Refer to pages 32 to 34 for details.)

- Output operation
- Simple setting mode
- Display color
- Delay time setting
- Digital filter setting
- FUNC output switching function
- Selectable analog output function
- External input function
- Forced output function
- Accumulated value hold
- Peak/Bottom value display
- Setting of security code
- Keylock function
- Reset to the default settings
- Display with zero cut-off setting
- Selection of display on sub screen
- Analog output free range function
- Error display function
- Copy function
- Selection of power saving mode

Mounting

The bracket configuration allows for mounting in four orientations.

Bracket A

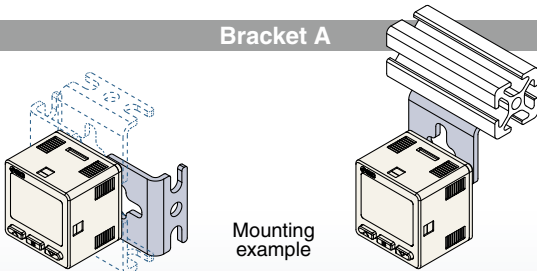

Bracket B

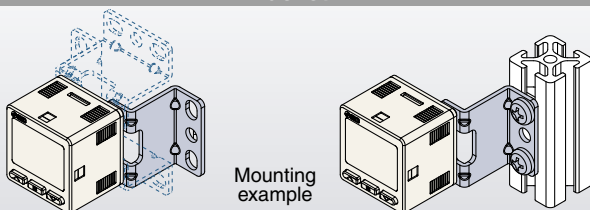

Panel mount

Mountable side by side without clearance

One opening!

- Reduced panel fitting labor
- Space saving

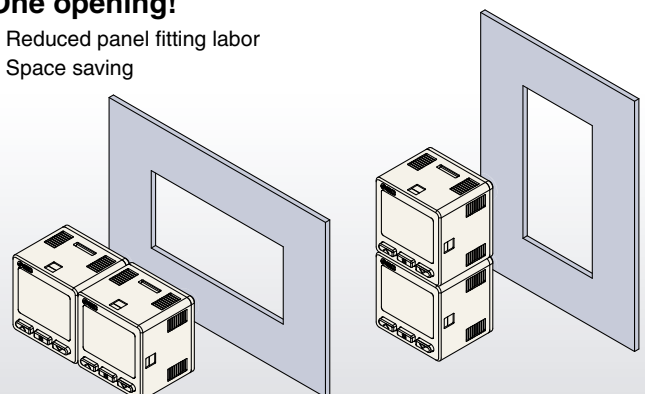

Input Range Selection (for Pressure/Flow rate)

The displayed value to the sensor input can be set as required.

(Voltage input: 1 to 5 V/Current input: 4 to 20 mA)

Pressure switch/Flow switch can be displayed.

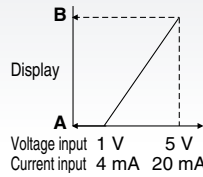

A is displayed for 1 V (or 4 mA).
B is displayed for 5 V (or 20 mA).
The range can be set as required.

■ Pressure Sensor for General Fluids/PSE570

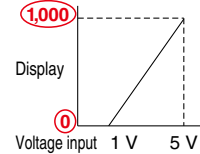

	A	B
PSE570	0	1,000
PSE573	-100	100
PSE574	0	500

Set A and B to the values shown in the table above.

Compact & Lightweight





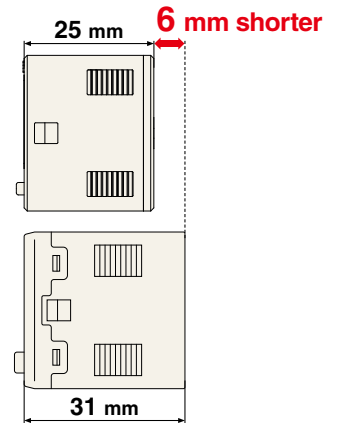



● Compact: Max. 6 mm shorter

● Lightweight: Max. 5 g lighter (30 g → 25 g)



Flow Switch Flow Rate Variations

Series	Applicable fluid	Detection method	Rated flow range [L/min]									
			-3	-2	-1	-0.5	0	0.5	1	2	3	
PFMV 	Dry air N ₂	Thermal type (MEMS)	0					0.5				
			0					1				
			0									3
					-0.5			0.5				
					-1				1			
		-3								3		

Series	Availability of the digital flow monitor PFG300	Applicable fluid	Detection method	Smallest settable increment	Rated flow range [L/min]																					
					0.2	0.5	1	2	5	10	20	25	50	100	150	200	300	500	600	1000	2000	3000	6000	12000		
PFM 	—	Dry air N ₂ Ar CO ₂	Thermal type (MEMS)	0.01 L/min																						
				0.1 L/min																						
PFMB p. 9   PFG300 p. 24 	—	Dry air N ₂	Thermal type (MEMS) Bypass flow type	1 L/min																						
PFMC  PFG300 	—	Dry air N ₂	Thermal type (MEMS) Bypass flow type	1 L/min																						
PF2A 	—	Air N ₂	Thermal type (Thermistor)	0.1 L/min																						
				0.5 L/min																						
				1 L/min																						
				2 L/min																						
				5 L/min																						
PF3A7□H  PFG300 	—	Air N ₂	Thermal type (Platinum sensor) Bypass flow type	2 L/min																						
				5 L/min																						
				10 L/min																						

Flow Switch Variations / Basic Performance Table

Series	PFMV	PFM	PFMB <small>p. 9</small>	PFMC	PF2A	PF3A7□H
Enclosure	IP40	IP40	IP40	IP65 [Monitor unit IP40]	IP65	IP65 [Monitor unit IP40]
Fluid	Dry air, N ₂	Dry air, N ₂ , Ar, CO ₂	Dry air, N ₂	Dry air, N ₂	Air, N ₂	Air, N ₂
Setting	Digital	Digital	Digital	Digital	Digital	Digital
Rated flow range	0 to 0.5 L/min -0.5 to 0.5 L/min 0 to 1 L/min -1 to 1 L/min 0 to 3 L/min -3 to 3 L/min	0.2 to 10 L/min 0.5 to 25 L/min 1 to 50 L/min 2 to 100 L/min	2 to 200 L/min 5 to 500 L/min 10 to 1000 L/min 20 to 2000 L/min	5 to 500 L/min 10 to 1000 L/min 20 to 2000 L/min	1 to 10 L/min 5 to 50 L/min 10 to 100 L/min 20 to 200 L/min 50 to 500 L/min	30 to 3000 L/min 60 to 6000 L/min 120 to 12000 L/min
Power supply voltage	12 to 24 VDC ±10%	24 VDC ±10%	12 to 24 VDC ±10%	12 to 24 VDC ±10%	12 to 24 VDC ±10%	24 VDC ±10%
Temperature characteristics (25°C standard)	±2% F.S. (15 to 35°C) ±5% F.S. (0 to 50°C) [Monitor unit] ±0.5% F.S. (0 to 50°C)	±2% F.S. (15 to 35°C) ±5% F.S. (0 to 50°C)	±2% F.S. (15 to 35°C) ±5% F.S. (0 to 50°C) [Monitor unit] ±0.5% F.S. (0 to 50°C)	±2% F.S. (15 to 35°C) ±5% F.S. (0 to 50°C) [Monitor unit] ±0.5% F.S. (0 to 50°C)	±3% F.S. (15 to 35°C) ±5% F.S. (0 to 50°C)	±5% F.S. (0 to 50°C) [Monitor unit] ±0.5% F.S. (0 to 50°C)
Repeatability	±1% F.S. (Fluid: Dry air) Analog output: ±5% F.S. [Monitor unit] ±0.1% F.S. Analog output: ±0.5% F.S.	±1% F.S. (Fluid: Dry air) Analog output: ±3% F.S.	±1% F.S. (Fluid: Dry air) [Monitor unit] ±0.1% F.S.	±1% F.S. (Fluid: Dry air) [Monitor unit] ±0.1% F.S.	±1% F.S. (PF2A7□0) ±2% F.S. (PF2A7□1)	±1% F.S. [Monitor unit] ±0.1% F.S.
Hysteresis	Hysteresis mode: Variable Window comparator mode: Variable	Hysteresis mode: Variable Window comparator mode: Variable	Hysteresis mode: Variable Window comparator mode: Variable	Hysteresis mode: Variable Window comparator mode: Variable	Hysteresis mode: Variable Window comparator mode: Fixed (3 digits)	Hysteresis mode: Variable Window comparator mode: Variable
Output	NPN/PNP open collector Analog voltage output Analog current output	NPN/PNP open collector Accumulated pulse output Analog voltage output Analog current output	NPN/PNP open collector Accumulated pulse output Analog voltage output Analog current output	NPN/PNP open collector Accumulated pulse output Analog voltage output Analog current output	NPN/PNP open collector Accumulated pulse output	NPN/PNP open collector Accumulated pulse output Analog voltage output Analog current output
Display	[Monitor unit 2-color LCD display]	2-color LED display	2-color LED display 2-color LCD display [Monitor unit 3-color LCD display]	3-color LCD display	LED display	3-color LCD display

* The monitor unit shows the PFG300 and PFMV3.

CONTENTS

2-Color Display

Digital Flow Switch *PFMB Series*

3-Screen Display

Digital Flow Monitor *PFG300 Series*



2-Color Display Digital Flow Switch PFMB Series

- How to Order p. 9
- Specifications p. 11
- Flow Range p. 12
- Analog Output p. 12
- Pressure Loss p. 12
- IN Side Straight Piping Length and Accuracy p. 12
- Internal Circuits and Wiring Examples p. 13
- Construction: Parts in Contact with Fluid p. 14
- Dimensions p. 15

3-Screen Display Digital Flow Monitor PFG300 series

- How to Order p. 24
- Specifications p. 25
- Internal Circuits and Wiring Examples p. 26
- Dimensions p. 27

- PFMB/Function Details** p. 30
- PFG300/Function Details** p. 32
- Safety Instructions** Back Cover

PFMB

PFG300

Function Details

2-Color Display

Digital Flow Switch

PFMB7 Series



RoHS

How to Order



PFMB7 201 [] - C8 [] - A [] - M [] []

Rated flow range (Flow rate range)

201	2 to 200 L/min
------------	----------------

Flow adjustment valve

Nil	None
S	Yes

Port size

C8	ø8 (5/16") One-touch fitting
02*1	Rc1/4
N02*1	NPT1/4
F02*1	G1/4 *2

*1 Made to order
*2 ISO1179-1 compliant

Piping entry direction

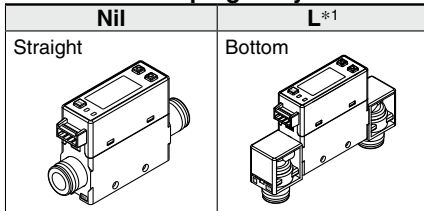

*1 Made to order

Output specification

	OUT1	OUT2	Applicable monitor unit model
A	NPN	NPN	—
B	PNP	PNP	—
C	NPN	Analog 1 to 5 V	PFG300 series
D	NPN	Analog 4 to 20 mA	PFG310 series
E*1	PNP	Analog 1 to 5 V	PFG300 series
F*1	PNP	Analog 4 to 20 mA	PFG310 series
G*1	NPN	External input *2	—
H*1	PNP	External input *2	—

*1 Made to order
*2 Accumulated flow value, peak/bottom flow value can be reset by external signal input.

Option 1

Nil	W
Lead wire with connector (2 m)	Lead wire with connector (2 m) + Rubber cover for connector (Silicone rubber)
N	* When only optional parts are required, refer to Option 1/Part Nos. on page 10.
Without lead wire with connector	

Calibration certificate *1

Nil	None
A*2	With calibration certificate

*1 Certificate in both English and Japanese
*2 Made to order

Unit specification

M	SI unit only *1
Nil	Units selection function *2

*1 Fixed unit: Instantaneous flow: L/min
Accumulated flow: L
*2 This product is for overseas use only according to the New Measurement Act. (The SI unit type is provided for use in Japan.)
Unit can be changed. Instantaneous flow: L/min ↔ cfm
Accumulated flow: L ↔ ft³

Option 2

Nil	R	S
No bracket	Bracket (For without flow adjustment valve) ZS-33-M With 2 tapping screws	Bracket (For with straight type flow adjustment valve) ZS-33-MS With 3 tapping screws
T	V	
Panel mount adapter (For without flow adjustment valve) ZS-33-J Panel mount adapter B	Panel mount adapter (For with flow adjustment valve) ZS-33-JS Panel mount adapter B	Panel mount adapter (For with flow adjustment valve) ZS-33-JS Panel mount adapter A
Mounting bracket	Mounting bracket	Mounting bracket

* Options are shipped together with the product, but not assembled.
When only optional parts are required, refer to Option 2/Part Nos. on page 10.

DIN Rail Mounting Bracket (Ordered Separately)

ZS-33-R []

Stations

1	1 station
2	2 stations
3	3 stations
4	4 stations
5	5 stations

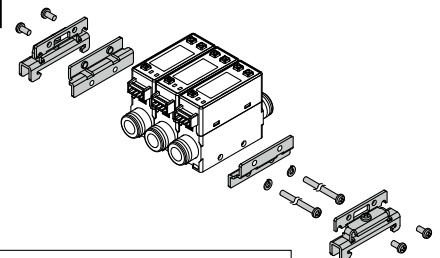

• The DIN rail should be provided by the customer.
• The DIN rail is not suitable for port size F02 (G1/4).



How to Order

PFMB7 **501** - **04** - **A** - **M**

Rated flow range (Flow rate range)

501	5 to 500 L/min
102	10 to 1000 L/min
202	20 to 2000 L/min

Thread type

Nil	Rc
N	NPT
F	G*1

*1 ISO228 compliant

Port size

	Port size	Rated flow range		
		501	102	202
04	1/2	●	●	—
06	3/4	—	—	●

Output specification

	OUT1	OUT2	Applicable monitor unit model
A	NPN	NPN	—
B	PNP	PNP	—
C	NPN	Analog 1 to 5 V	PFG300 series
D	NPN	Analog 4 to 20 mA	PFG310 series
E *1	PNP	Analog 1 to 5 V	PFG300 series
F *1	PNP	Analog 4 to 20 mA	PFG310 series
G *1	NPN	External input*2	—
H *1	PNP	External input*2	—

*1 Made to order

*2 Accumulated flow value, peak/bottom flow value can be reset by external signal input.

Option 1

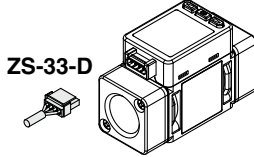
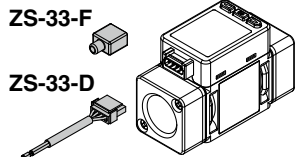
Nil	W
Lead wire with connector (2 m)	Lead wire with connector (2 m) + Rubber cover for connector (Silicone rubber)
	
N	* When only optional parts are required, refer to Option 1/Part Nos. below.
Without lead wire with connector	

Calibration certificate *1

Nil	None
A *2	With calibration certificate

*1 Certificate in both English and Japanese

*2 Made to order

Option 2

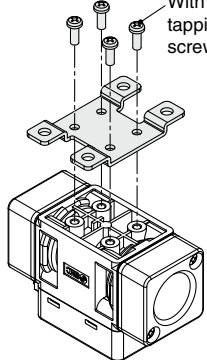
Nil	R
No bracket	With bracket 

* Options are shipped together with the product, but not assembled. When only optional parts are required, refer to Option 2/Part Nos. below.

Unit specification

M	SI unit only*1
Nil	Units selection function*2

*1 Fixed unit: Instantaneous flow: L/min
Accumulated flow: L

*2 This product is for overseas use only according to the New Measurement Act. (The SI unit type is provided for use in Japan.)

Unit can be changed. Instantaneous flow: L/min ↔ cfm
Accumulated flow: L ↔ ft³

Option 1/Part Nos.

Option	Part no.	Qty.	Note
Lead wire with connector	ZS-33-D	1	Lead wire: 2 m
Rubber cover (Silicone rubber)	ZS-33-F	1	For connector

Option 2/Part Nos.

Option	Part no.	Qty.	Note
Bracket (for PFMB7201)	ZS-33-M	1	With 2 tapping screws (3 x 6)
Bracket (for PFMB7201S)	ZS-33-MS	1	With 3 tapping screws (3 x 6)
Panel mount adapter (for PFMB7201)	ZS-33-J	1	
Panel mount adapter (for PFMB7201S)	ZS-33-JS	1	
Bracket (for PFMB7501/7102)	ZS-42-C	1	With 4 tapping screws (3 x 6)
Bracket (for PFMB7202)	ZS-42-D	1	With 4 tapping screws (3 x 6)

PFMB7 Series

For flow switch precautions and specific product precautions, refer to the "Operation Manual" on the SMC website.

Specifications

Model		PFMB7201	PFMB7501	PFMB7102	PFMB7202
Fluid	Applicable fluid *1	Dry air, N ₂ (Air quality grade is JIS B 8392-1 1.1.2 to 1.6.2, ISO 8573-1 1.1.2 to 1.6.2)			
	Fluid temperature range	0 to 50°C			
Flow	Detection method	Thermal type			
	Rated flow range	2 to 200 L/min	5 to 500 L/min	10 to 1000 L/min	20 to 2000 L/min
	Set point range	Instantaneous flow 2 to 210 L/min	Instantaneous flow 5 to 525 L/min	Instantaneous flow 10 to 1050 L/min	Instantaneous flow 20 to 2100 L/min
	Smallest settable increment	Instantaneous flow 0 to 999,999,999 L	1 L/min		0 to 999,999,990 L
	Accumulated volume per pulse (Pulse width = 50 ms)	1 L		10 L	
	Accumulated value hold function *2	1 L/pulse			
	Accumulated value hold function *2	Intervals of 2 or 5 minutes can be selected.			
Pressure	Rated pressure range	0 to 0.75 MPa	0 to 0.8 MPa		
	Proof pressure	1.0 MPa	1.2 MPa		
	Pressure loss	Refer to "Pressure Loss" graph.			
Electrical	Pressure characteristics *3	±5% F.S. (0 to 0.75 MPa, 0.35 MPa standard)			
	Power supply voltage	±5% F.S. (0 to 0.8 MPa, 0.6 MPa standard)			
	Current consumption	12 to 24 VDC ±10%			
Accuracy *11	Protection	55 mA or less			
	Display accuracy	Polarity protection			
	Analog output accuracy	±3% F.S.			
	Repeatability	±3% F.S.			
	Temperature characteristics	±1% F.S. (±2% F.S. when the response time is set to 0.05 s)			
	Output type	±5% F.S. (0 to 50°C, 25°C standard)			
	Output mode	NPN open collector PNP open collector			
Switch output	Switch operation	Select from Hysteresis, Window comparator, Accumulated output, or Accumulated pulse output modes.			
	Maximum load current	Select from Normal or Reversed output.			
	Maximum applied voltage (NPN only)	80 mA			
	Internal voltage drop (Residual voltage)	28 VDC			
	Response time *4	NPN output type: 1 V or less (at load current of 80 mA) PNP output type: 1.5 V or less (at load current of 80 mA)			
	Hysteresis *5	Select from 0.05 s, 0.1 s, 0.5 s, 1 s, or 2 s.			
	Protection	Variable from 0			
Analog output *6	Output type	Short circuit protection			
	Impedance	Voltage output: 1 to 5 V, Current output: 4 to 20 mA			
	Response time *7	Output impedance: Approx. 1 kΩ			
External input *8	External input	Maximum load impedance at power supply voltage of 24 V: 600 Ω, at power supply voltage of 12 V: 300 Ω			
	Input mode	Input voltage: 0.4 V or less (Reed or Solid state) for 30 ms or longer			
Display	Reference condition *9	Select from Accumulated value external reset or Peak/Bottom value reset.			
	Display mode	Select from Standard conditions or Normal conditions.			
	Unit *10	Select from Instantaneous flow or Accumulated flow.			
	Display range	L/min or cfm can be selected.			
	Minimum display unit	L or ft ³ can be selected.			
	Display	LED, Color: Red/Green, 3 digits, 7 segments			
	Indicator LED	LED ON when switch output is ON (OUT1: Green, OUT2: Red)			
Environment	Enclosure	IP40			
	Withstand voltage	1000 VAC for 1 minute between terminals and housing			
	Insulation resistance	50 MΩ or more (500 VDC measured via megohmmeter) between terminals and housing			
	Operating temperature range	Operating: 0 to 50°C, Stored: -10 to 60°C (No condensation or freezing)			
Standards	Operating humidity range	Operating/Stored: 35 to 85% RH (No condensation or freezing)			
	Piping specification	CE, UL (CSA), RoHS		CE, RoHS	
Piping	Piping entry direction	Rc1/4, NPT1/4, G1/4, ø8 One-touch fitting	Rc1/2, NPT1/2, G1/2	Rc3/4, NPT3/4, G3/4	
	Main materials of parts in contact with fluid *12	Straight, Bottom			
Weight	Body	FKM, Stainless steel 304, PPS, PBT, Brass (Electroless nickel plating), HNBR, Si, Au, GE4F	ADC, PPS, Stainless steel 304, Au, HNBR, Si, GE4F		155 g
	Flow adjustment valve	Rc1/4, NPT1/4/Straight: 70 g, Bottom: 85 g G1/4/Straight: 115 g, Bottom: 130 g ø8 One-touch fitting/Straight: 50 g, Bottom: 65 g	100 g		
	Lead wire	+45 g		—	
	Bracket	+20 g		+35 g	
	Panel mount adapter	+15 g		+25 g	
DIN rail mounting bracket	+65 g		—		

- *1 Refer to the "Example of recommended pneumatic circuit" on page 2.
- *2 When using the accumulated value hold function, use the operating conditions to calculate the product life, and do not exceed it. The maximum access limit of the memory device is 1 million times. If the product is operated 24 hours per day, the product life will be as follows:
 • 5 min interval: life is calculated as 5 min x 1 million = 5 million min = 9.5 years
 • 2 min interval: life is calculated as 2 min x 1 million = 2 million min = 3.8 years
 If the accumulated value external reset is repeatedly used, the product life will be shorter than the calculated life.
- *3 Do not release the OUT side piping port of the product directly to the atmosphere without connecting piping. If the product is used with the piping port released to atmosphere, accuracy may vary.
- *4 The time from when the flow is changed by a step input (when the flow rate changes from 0 to the maximum value of the rated flow range instantaneously) until the switch output turns ON (or OFF) when set to be 90% of the rated flow rate
- *5 If the flow fluctuates around the set value, the width for setting more than

- the fluctuating width needs to be set. Otherwise, chattering will occur.
- *6 When using a product with an analog output
- *7 The time from when the flow is changed by a step input (when the flow rate changes from 0 to the maximum value of the rated flow range instantaneously) until the analog output reaches 90% of the rated flow rate
- *8 When using a product with an external input
- *9 The flow rate given in the specifications is the value under standard conditions.
- *10 Setting is only possible for models with the units selection function.
- *11 For details, refer to "IN Side Straight Piping Length and Accuracy" on page 12.
- *12 For details, refer to "Construction: Parts in Contact with Fluid" on page 14.
- *13 The accumulated flow display is the upper 3-digit, middle 3-digit, and lower 3-digit (total of 9 digits) display. The position of the dots on the upper part of the screen indicates which digits are displayed.
- * Products with tiny scratches, marks, or display color or brightness variations which do not affect the performance of the product are verified as conforming products.

Flow Range

Model	Flow range					
	-100 L/min	0 L/min	200 L/min	500 L/min	1000 L/min	2000 L/min
PFMB7201		2 L/min	200 L/min			
		2 L/min	210 L/min			
		-10 L/min	210 L/min			
PFMB7501		5 L/min	500 L/min			
		5 L/min	525 L/min			
		-25 L/min	525 L/min			
PFMB7102		10 L/min	1000 L/min			
		10 L/min	1050 L/min			
		-50 L/min	1050 L/min			
PFMB7202		20 L/min	2000 L/min			
		20 L/min	2100 L/min			
		-100 L/min	2100 L/min			

Rated flow range Set point range Display range

Analog Output

Flow/Analog Output

	A	B	C
Voltage output	1 V	1.04 V	5 V
Current output	4 mA	4.16 mA	20 mA

Model	Minimum value of the rated flow range	Maximum value of the rated flow range
PFMB7201	2 L/min	200 L/min
PFMB7501	5 L/min	500 L/min
PFMB7102	10 L/min	1000 L/min
PFMB7202	20 L/min	2000 L/min

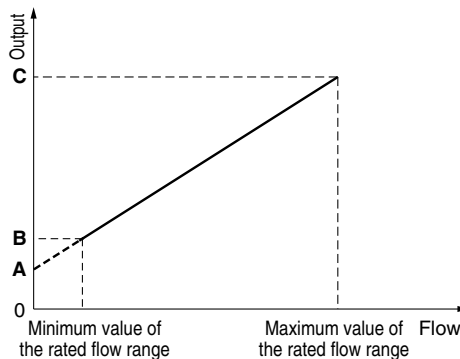

Flow Adjustment Valve Flow Rate Characteristics

PFMB7201 (for 200 L/min)

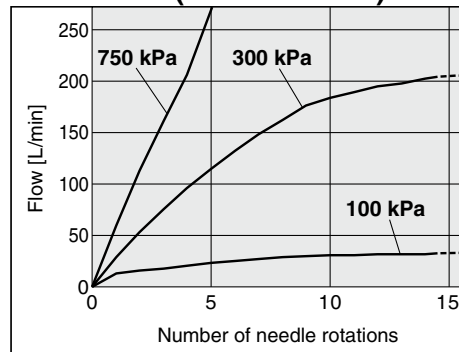

Pressure Loss (Reference Data)

PFMB7201 (for 200 L/min) (Without flow adjustment valve)

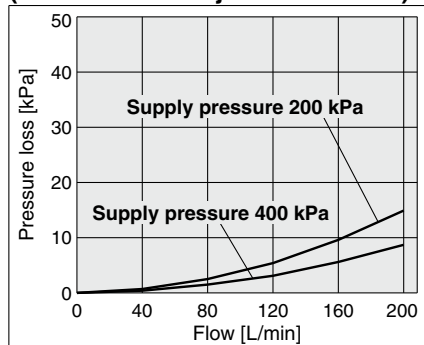

PFMB7501 (for 500 L/min)

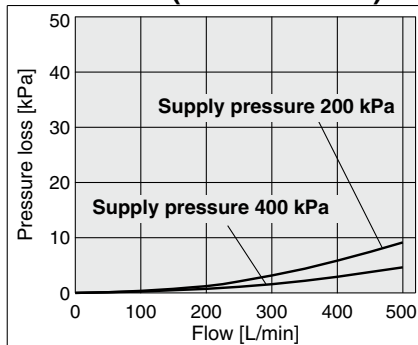

PFMB7102 (for 1000 L/min)

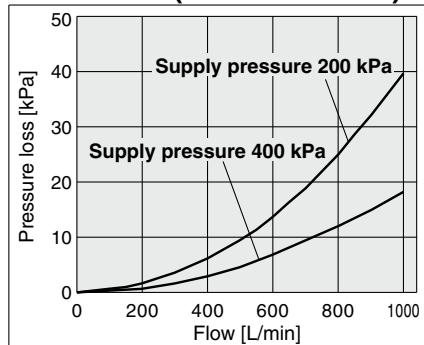

PFMB7202 (for 2000 L/min)

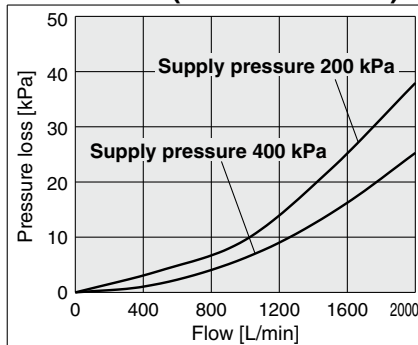

IN Side Straight Piping Length and Accuracy (Reference Data)

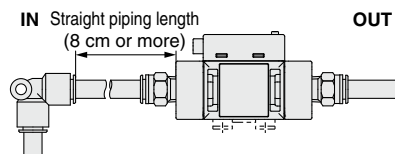

- The piping on the IN side must have a straight section of piping with a length of 8 cm or more. If a straight section of piping is not installed, the accuracy can vary by approximately $\pm 2\%$ F.S.
 - * "Straight section" means a part of the piping without any bends or rapid changes in the cross sectional area.
 - When the PFMB7201 is connected to tubing, use a tube I.D. 5 mm just before the product.
 - When the PFMB7501 or 7102 is connected to tubing, use a tube I.D. 9 mm or more just before the product.
- The accuracy can vary by approximately $\pm 2\%$ F.S. when such tubing is not used.

PFMB7201/7501/7102/7202

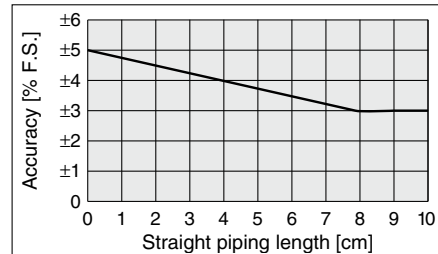

PFMB7 Series

Internal Circuits and Wiring Examples

NPN (2 outputs) type

PFMB7□□□-□□-**A**□-□□□

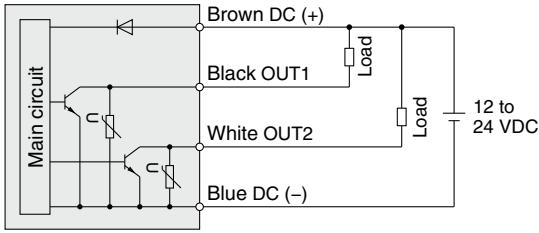

Max. applied voltage: 28 V, Max. load current: 80 mA, Internal voltage drop: 1 V or less

PNP (2 outputs) type

PFMB7□□□-□□-**B**□-□□□

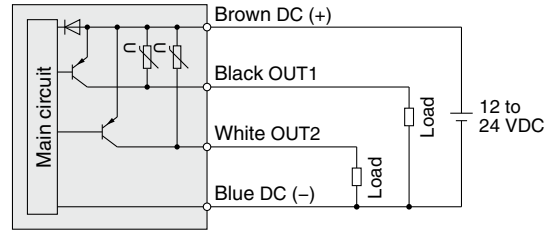

Max. load current: 80 mA, Internal voltage drop: 1.5 V or less

NPN (1 output) + Analog (1 to 5 V) output type

PFMB7□□□-□□-**C**□-□□□

NPN (1 output) + Analog (4 to 20 mA) output type

PFMB7□□□-□□-**D**□-□□□

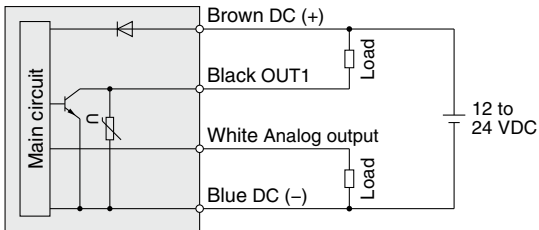

Max. applied voltage: 28 V, Max. load current: 80 mA, Internal voltage drop: 1 V or less

C: Analog output: 1 to 5 V

Output impedance: 1 kΩ

D: Analog output: 4 to 20 mA

Max. load impedance: 600 Ω

PNP (1 output) + Analog (1 to 5 V) output type

PFMB7□□□-□□-**E**□-□□□

PNP (1 output) + Analog (4 to 20 mA) output type

PFMB7□□□-□□-**F**□-□□□

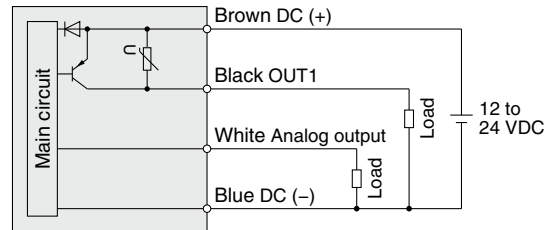

Max. load current: 80 mA, Internal voltage drop: 1.5 V or less

E: Analog output: 1 to 5 V

Output impedance: 1 kΩ

F: Analog output: 4 to 20 mA

Max. load impedance: 600 Ω

NPN (1 output) + External input type

PFMB7□□□-□□-**G**□-□□□

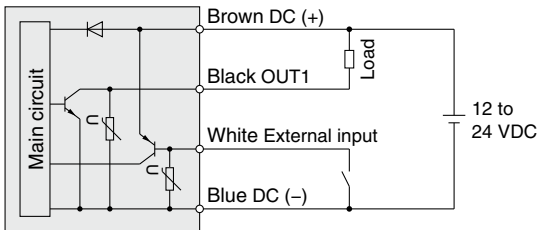

Max. applied voltage: 28 V, Max. load current: 80 mA, Internal voltage drop: 1 V or less

External input: Input voltage 0.4 V or less (Reed or Solid state input) for 30 ms or longer

PNP (1 output) + External input type

PFMB7□□□-□□-**H**□-□□□

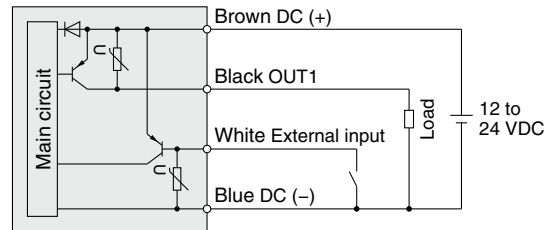

Max. load current: 80 mA, Internal voltage drop: 1.5 V or less

External input: Input voltage 0.4 V or less (Reed or Solid state input) for 30 ms or longer

Accumulated pulse output wiring examples

NPN (2 outputs) type

PFMB7□□□-□□-**A**□-□□□

NPN (1 output) + Analog output type

PFMB7□□□-□□-**C**□-□□□

PFMB7□□□-□□-**D**□-□□□

NPN (1 output) + External input type

PFMB7□□□-□□-**G**□-□□□

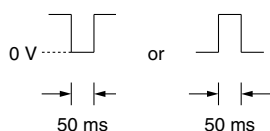
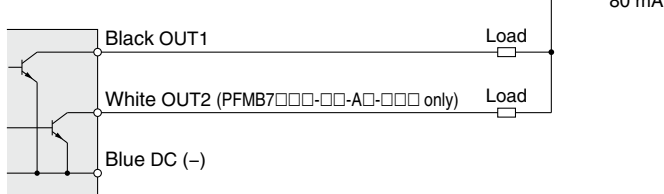

PNP (2 outputs) type

PFMB7□□□-□□-**B**□-□□□

PNP (1 output) + Analog output type

PFMB7□□□-□□-**E**□-□□□

PFMB7□□□-□□-**F**□-□□□

PNP (1 output) + External input type

PFMB7□□□-□□-**H**□-□□□

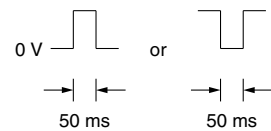
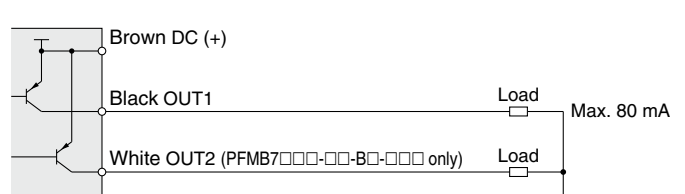

Construction: Parts in Contact with Fluid

PFMB7201

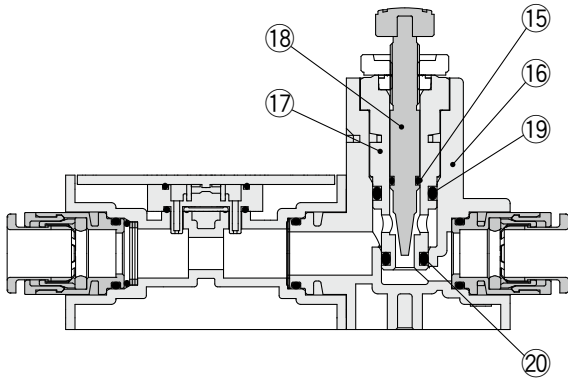
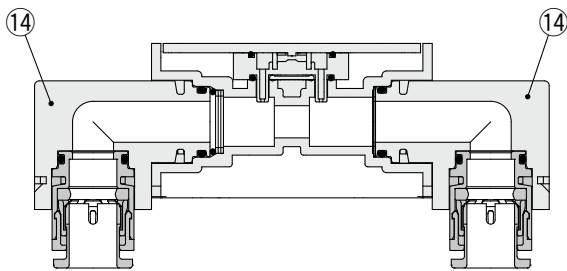
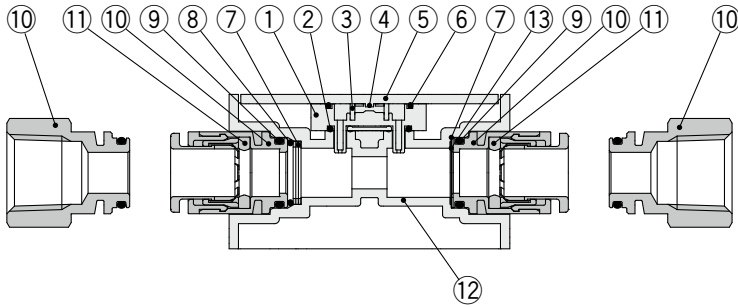

Component Parts

No.	Description	Material	Note
1	Sensor body	PPS	
2	Gasket	HNBR	
3	Flow rectifier	Stainless steel 304	
4	Sensor chip	Silicon	
5	Printed circuit board	GE4F	
6	Gasket	HNBR	
7	Flow rectifier	Stainless steel 304	
8	O-ring	FKM	Fluoro coating
9	O-ring	FKM	Fluoro coating
10	Fitting for piping	Brass	Electroless nickel plating
11	O-ring	FKM	Fluoro coating
12	Body	PBT	
13	Gasket	HNBR	
14	Bottom piping adapter	PBT	
15	O-ring	HNBR	Fluoro coating
16	Flow adjustment valve body	PBT	
17	Body	Brass	Electroless nickel plating
18	Needle	Brass	Electroless nickel plating
19	O-ring	HNBR	Fluoro coating
20	O-ring	HNBR	Fluoro coating

PFMB7501/7102/7202

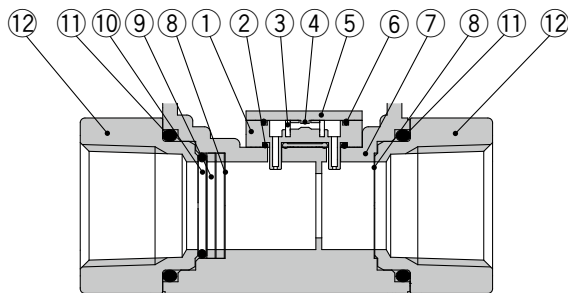

Component Parts

No.	Description	Material	Note
1	Sensor body	PPS	
2	Gasket	HNBR	
3	Flow rectifier	Stainless steel 304	
4	Sensor chip	Silicon	
5	Printed circuit board	GE4F	
6	Gasket	HNBR	
7	Body	PPS	
8	Mesh	Stainless steel 304	
9	Spacer	PPS	
10	O-ring	HNBR	
11	O-ring	HNBR	
12	Attachment	ADC	Coating

PFMB

PFGB300

Function Details

PFMB7 Series

Dimensions

PFMB7201-C8

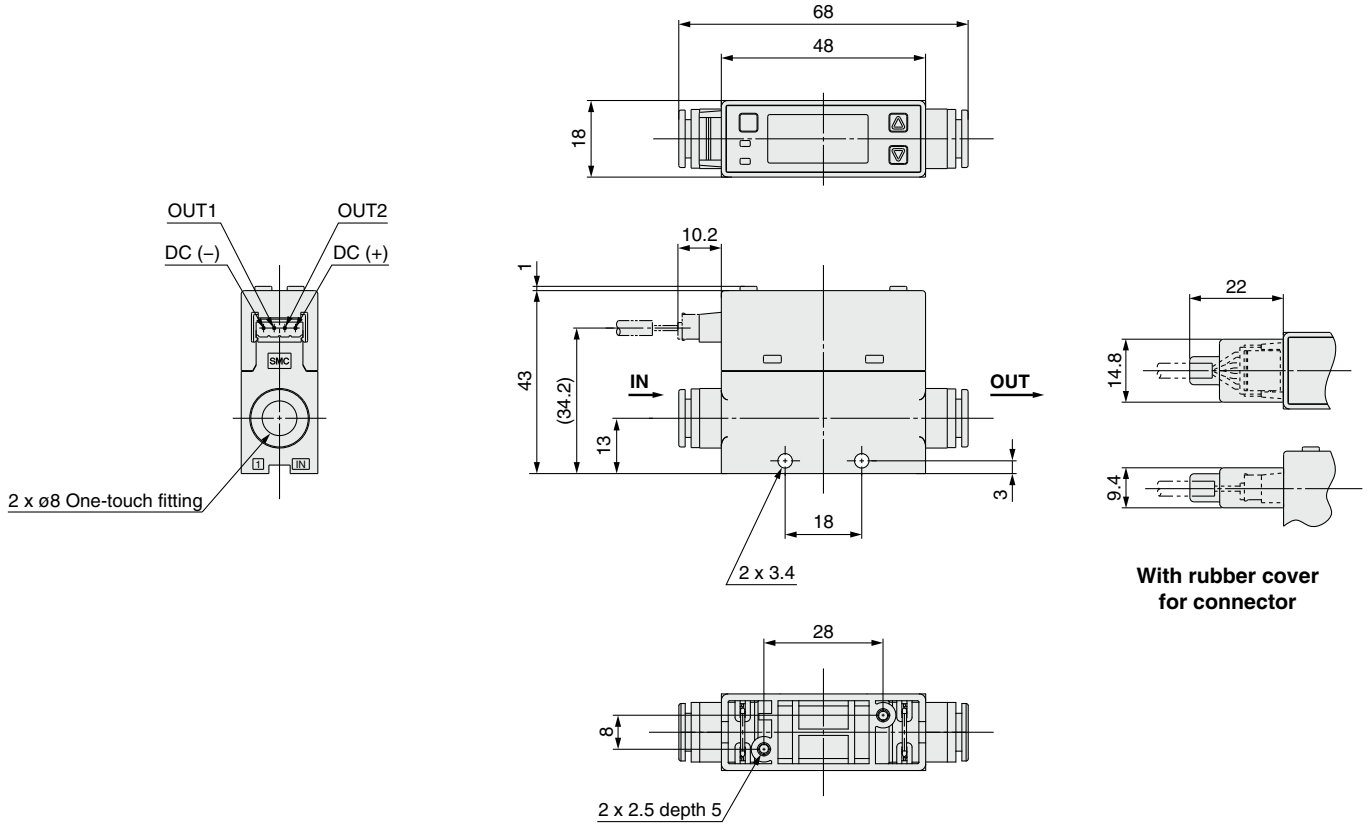

PFMB7201-C8L

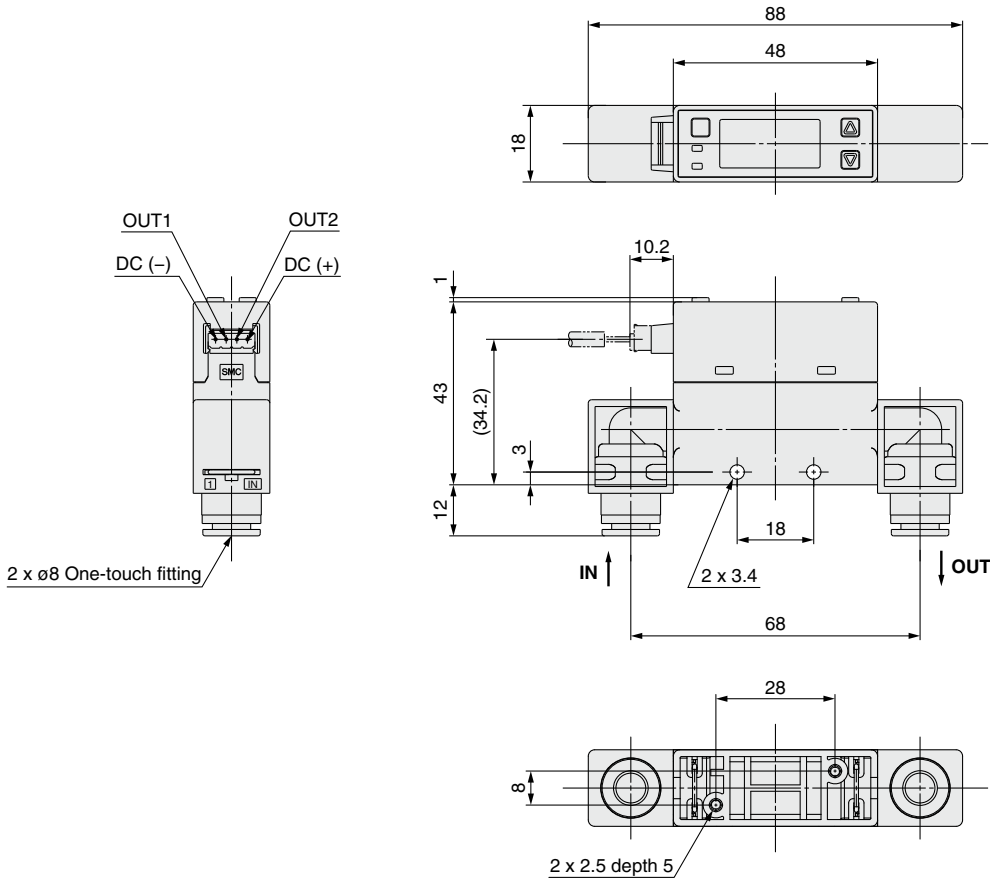

Dimensions

PFMB7201-(N)02

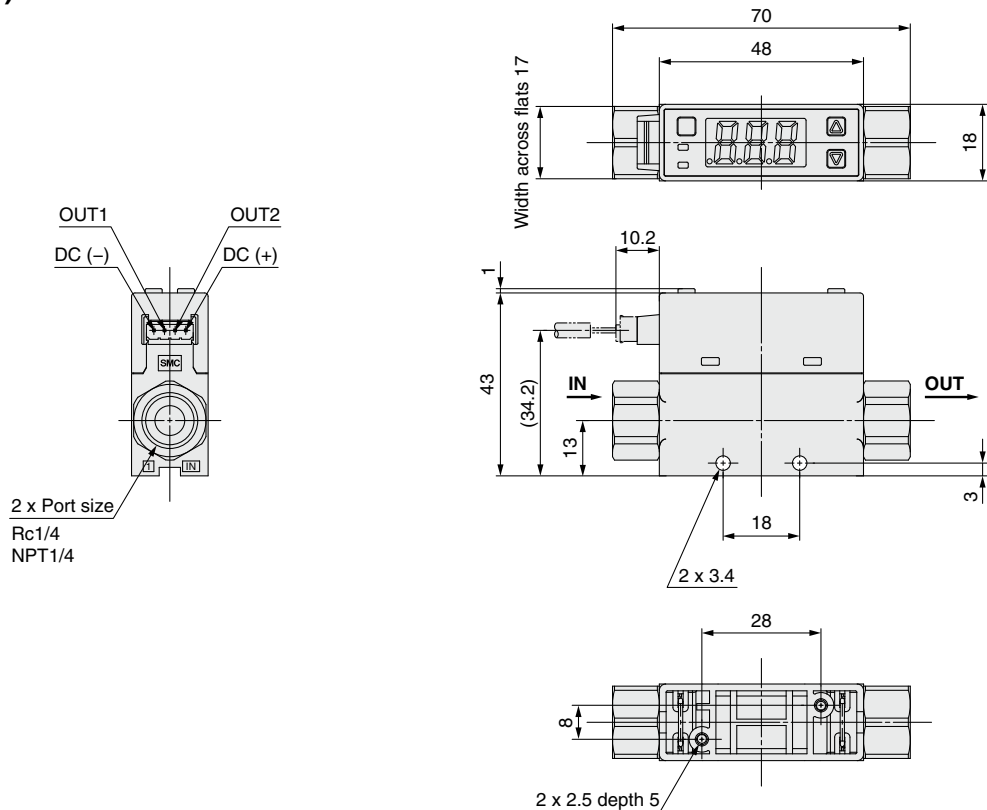

PFMB7201-(N)02L

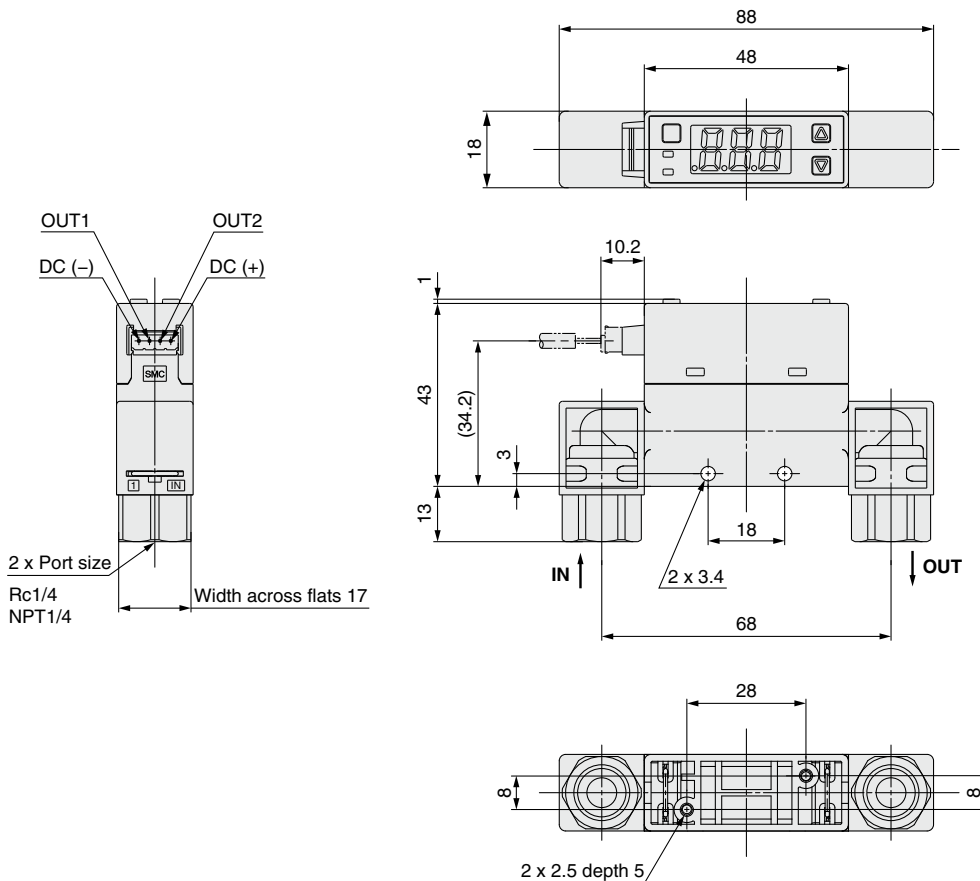

PFMB

PFGB300

Function Details

PFMB7 Series

Dimensions

PFMB7201-F02

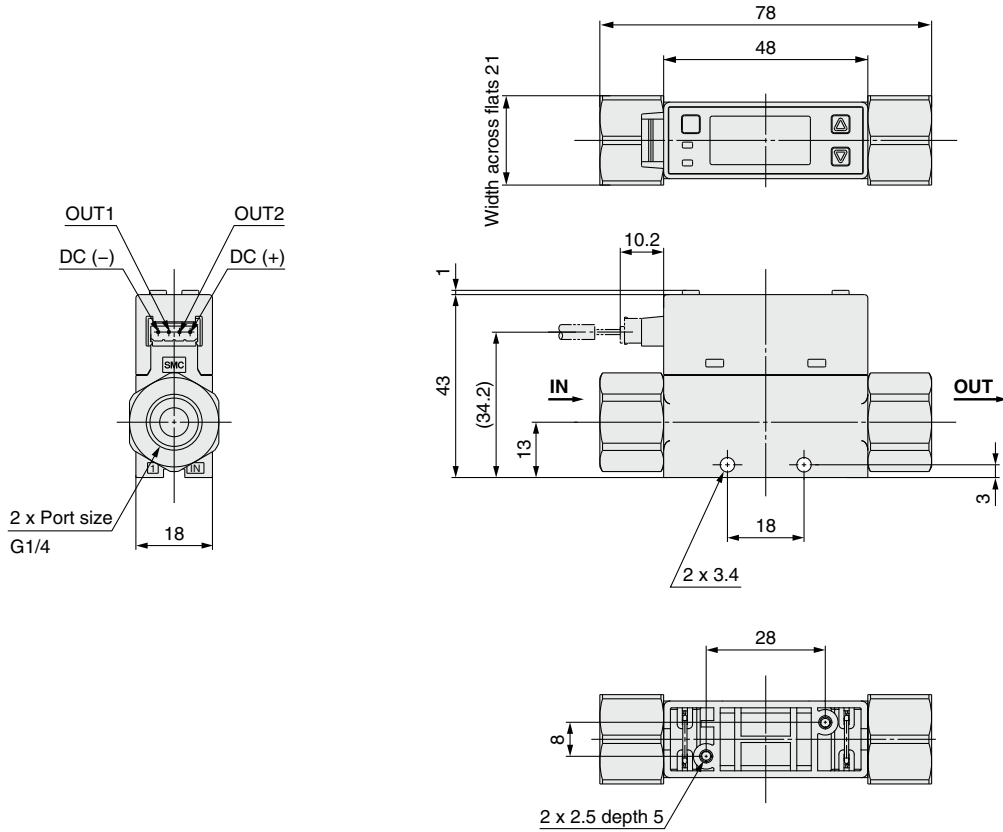

PFMB7201-F02L

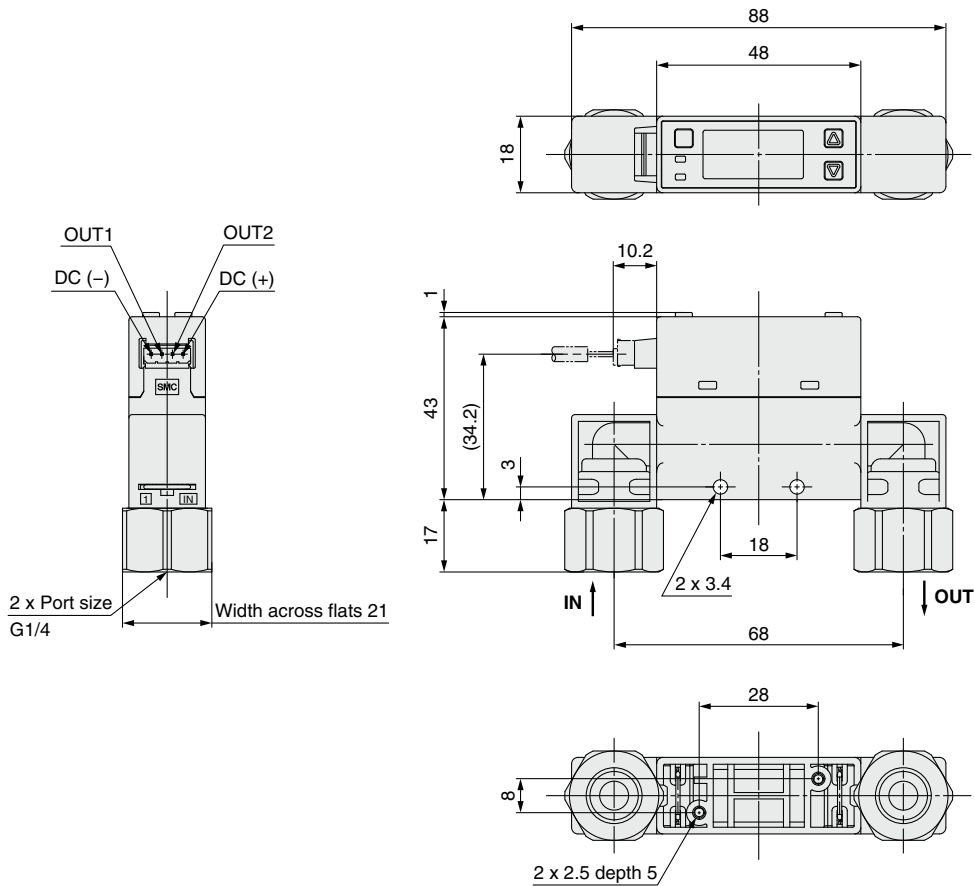

Dimensions

PFMB7201S-C8

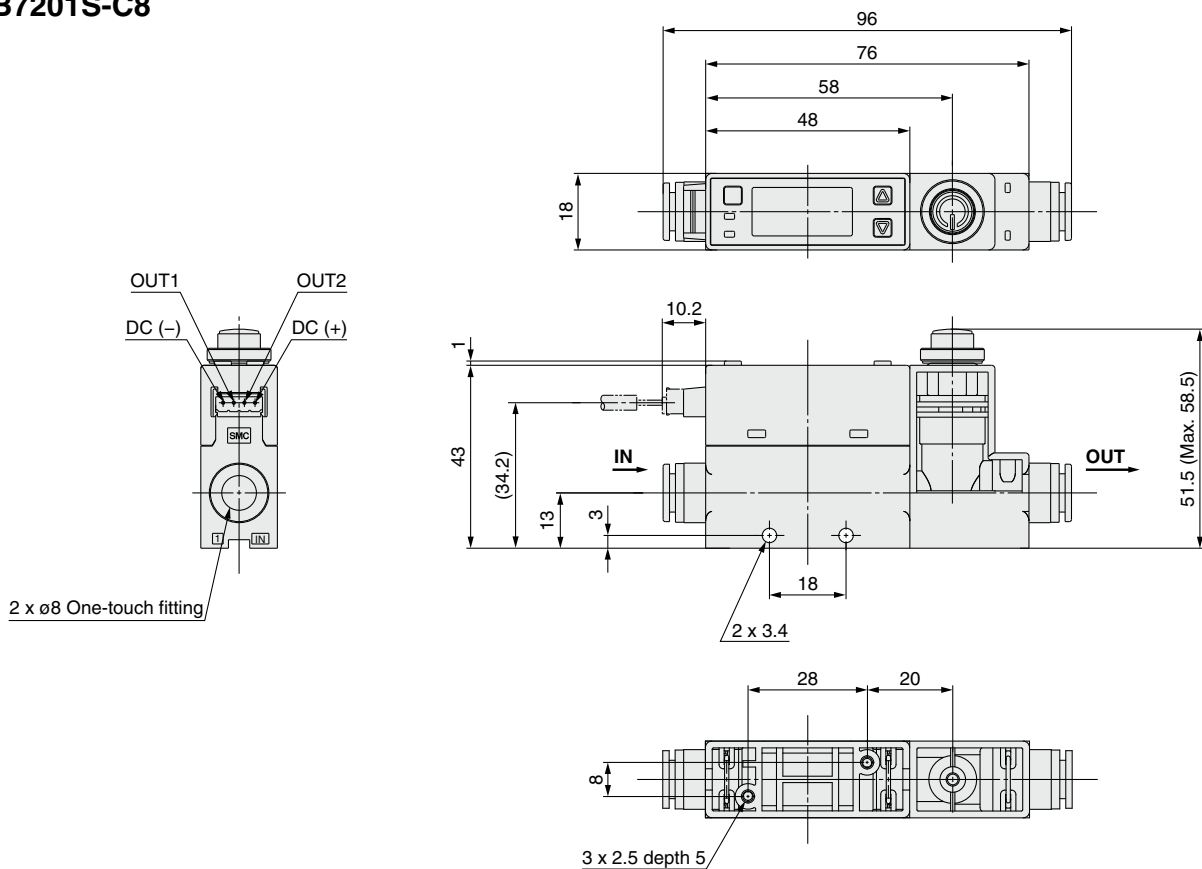

PFMB7201S-C8L

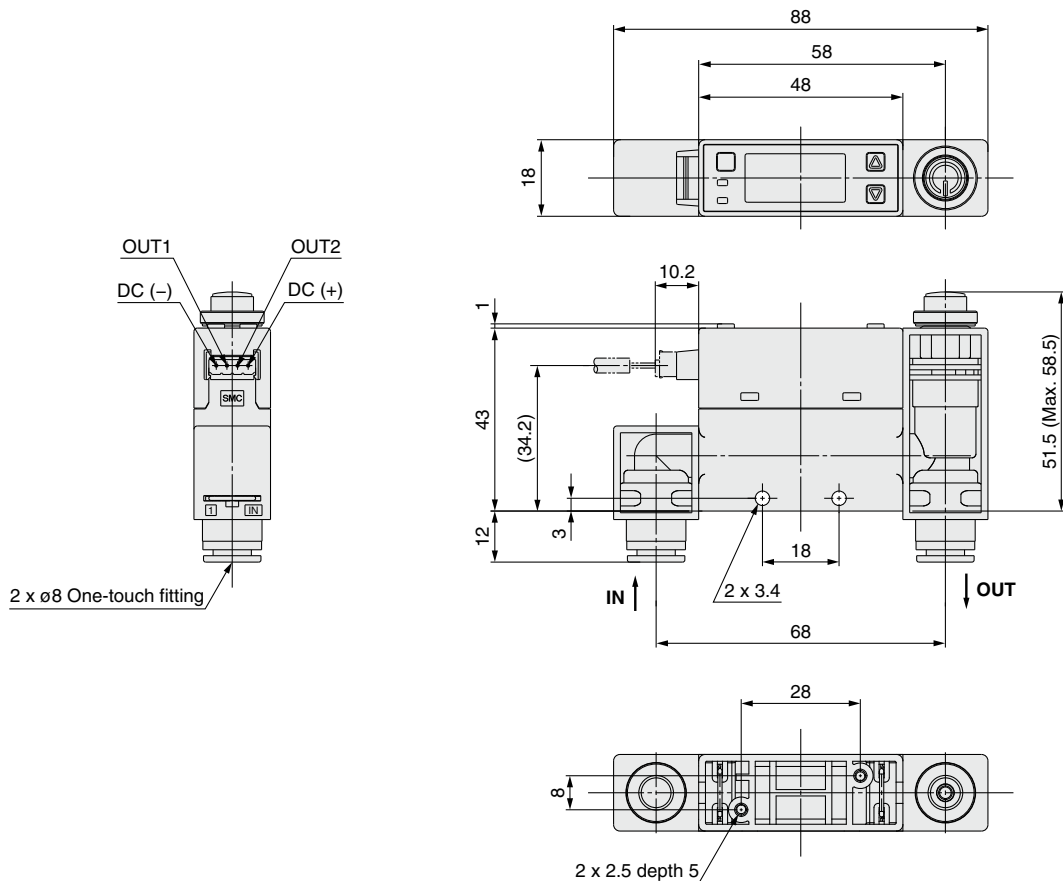

PFMB7 Series

Dimensions

PFMB7201S-(N)02

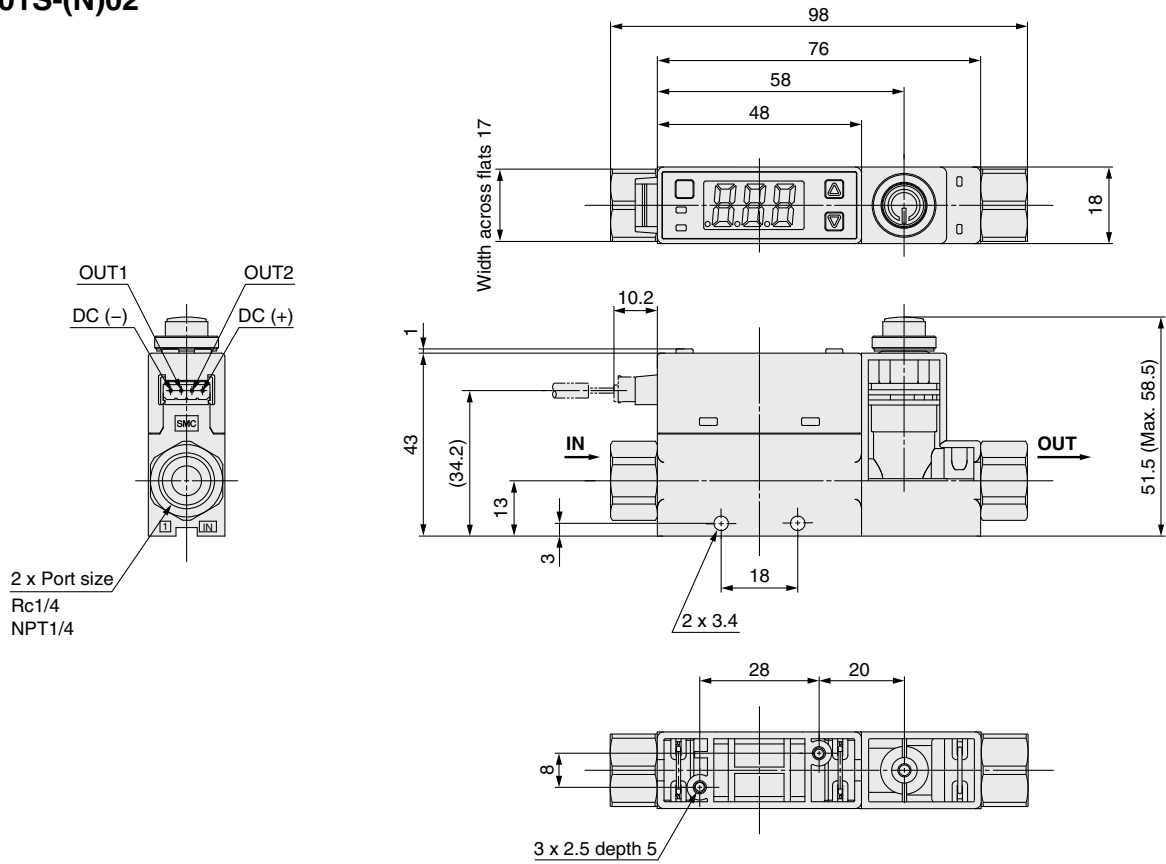

PFMB7201S-(N)02L

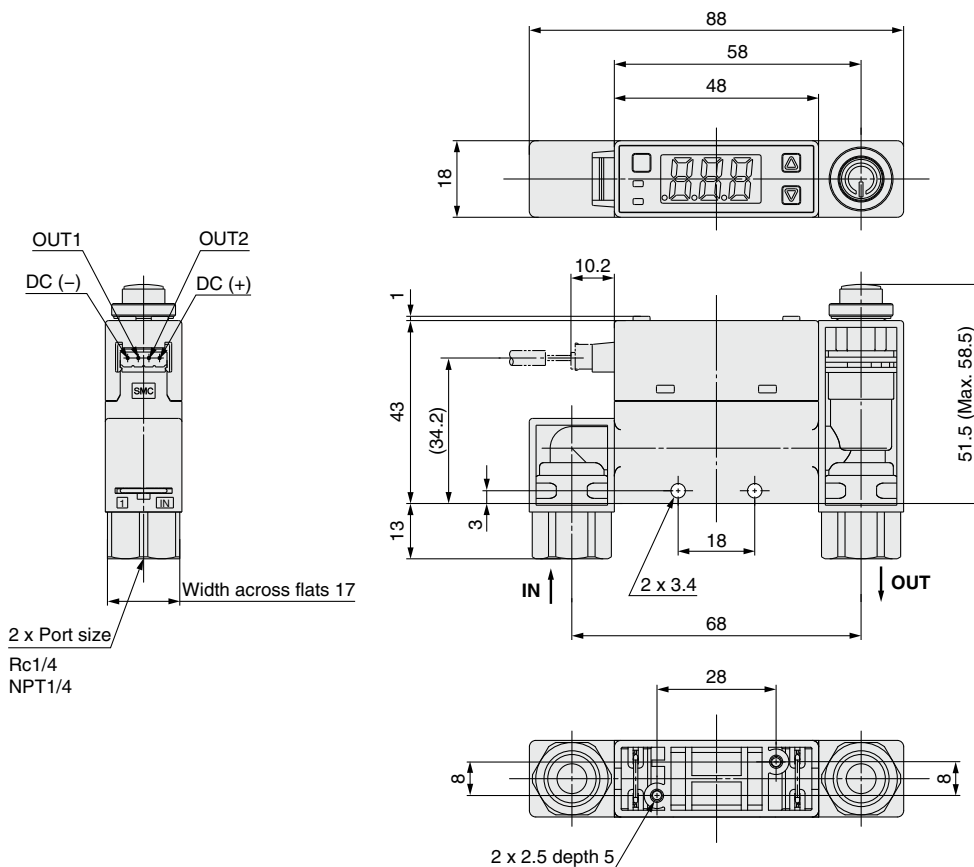

Dimensions

PFMB7201S-F02

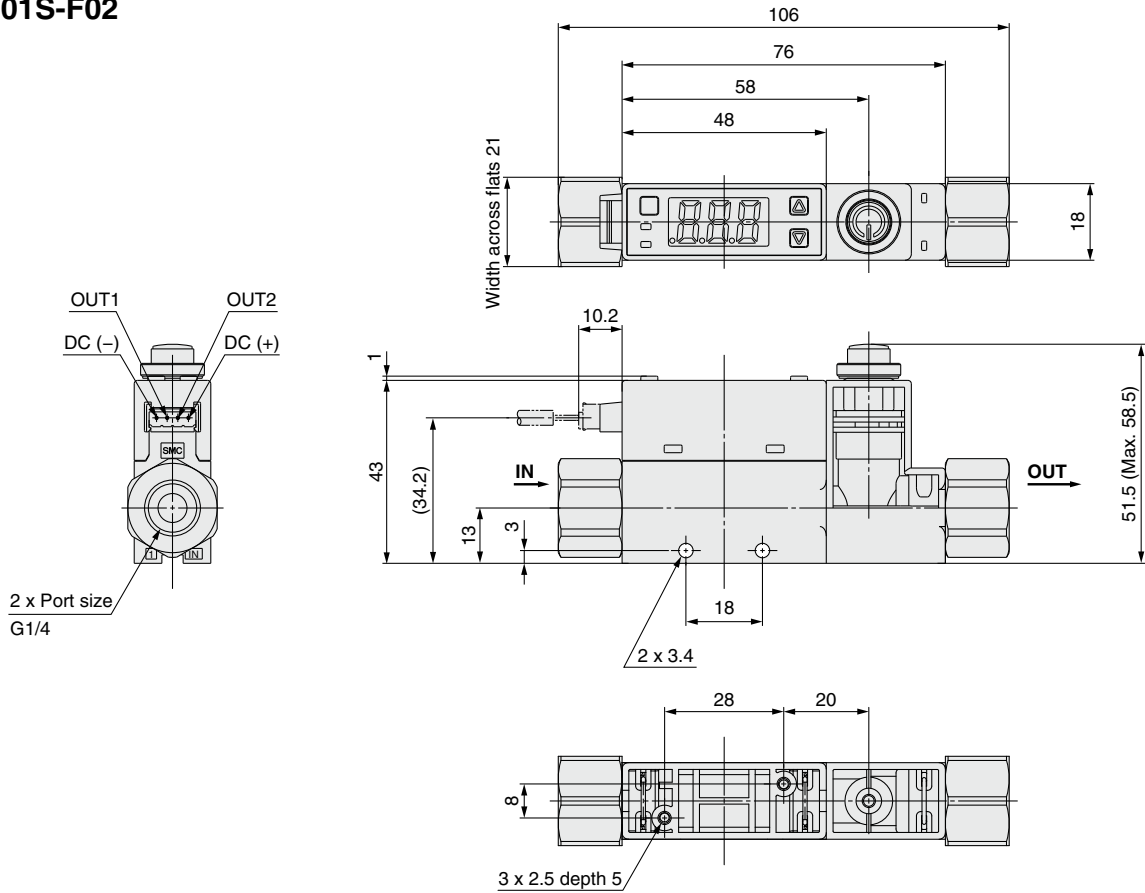

PFMB7201S-F02L

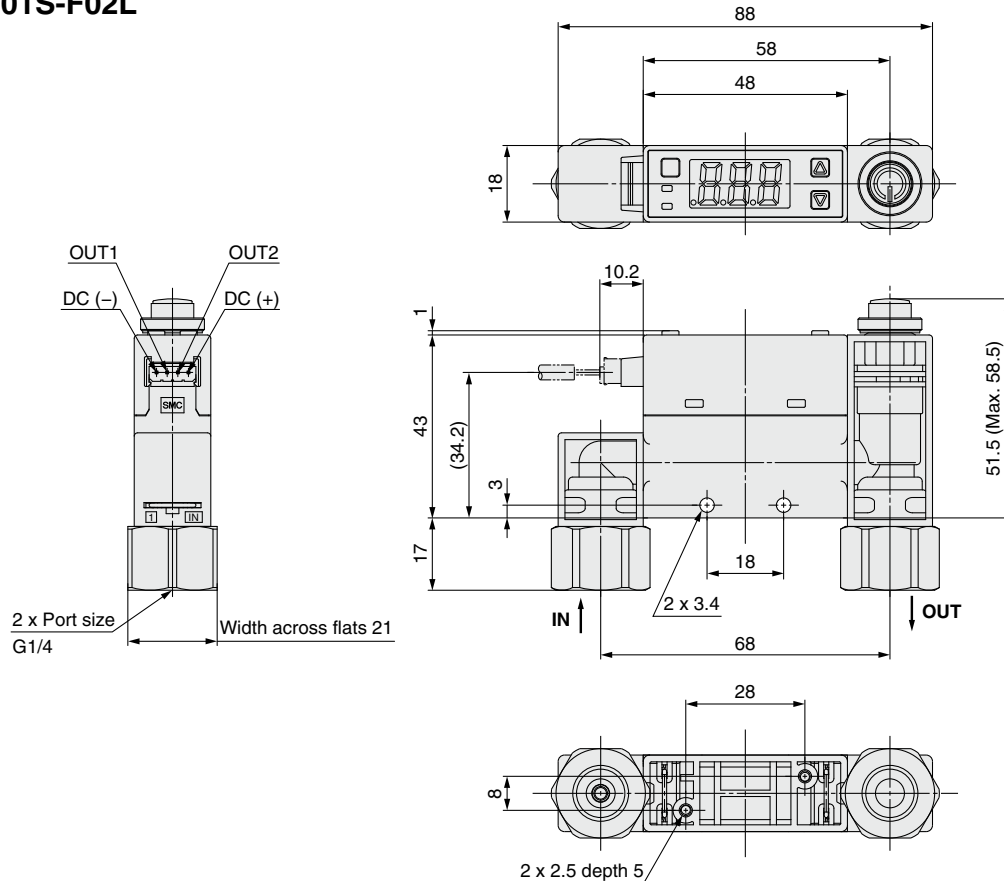

PFMB7 Series

Dimensions

PFMB7201

Panel mount/
Without flow adjustment valve/Straight

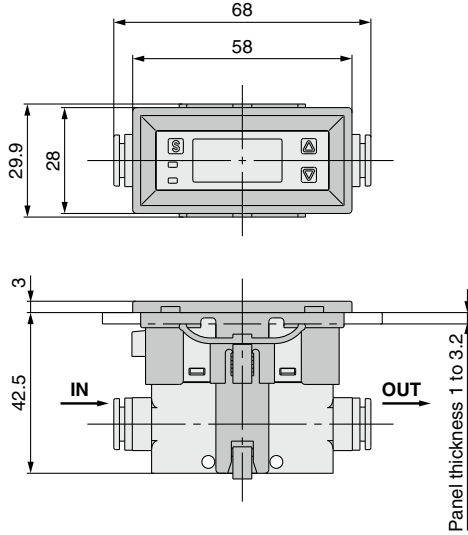

Panel mount/
Without flow adjustment valve/Bottom

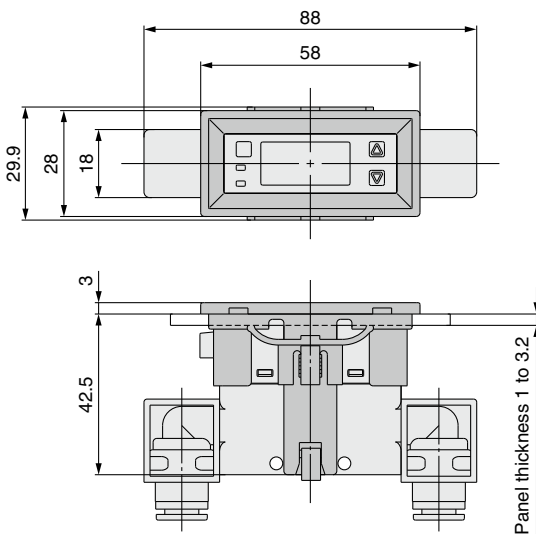

Panel Fitting Dimensions

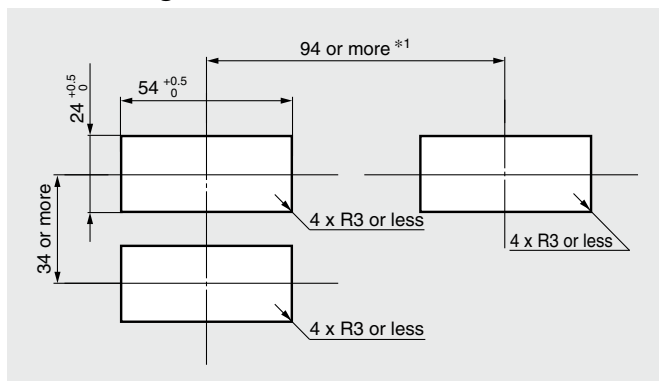

Panel thickness 1 to 3.2 mm

*1 Piping entry direction: Minimum dimensions for bottom piping. If using straight piping, the piping material and tubing need to be taken into consideration when designing the system. If a bend (R) is used, limit it to R3 or less.

Panel mount/
With flow adjustment valve/Straight

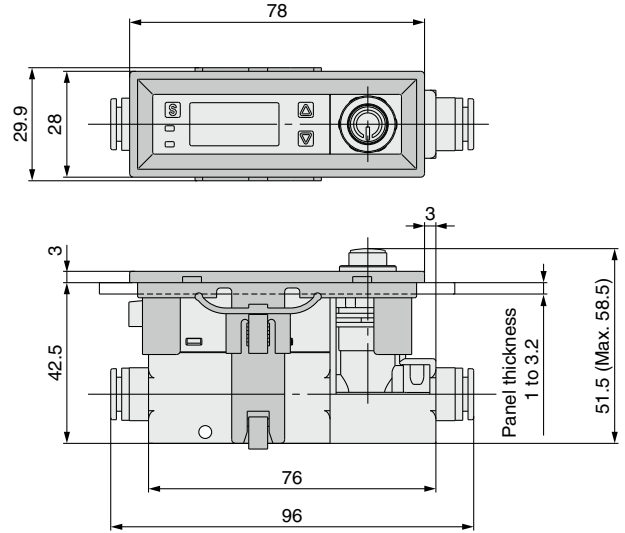

Panel mount/
With flow adjustment valve/Bottom

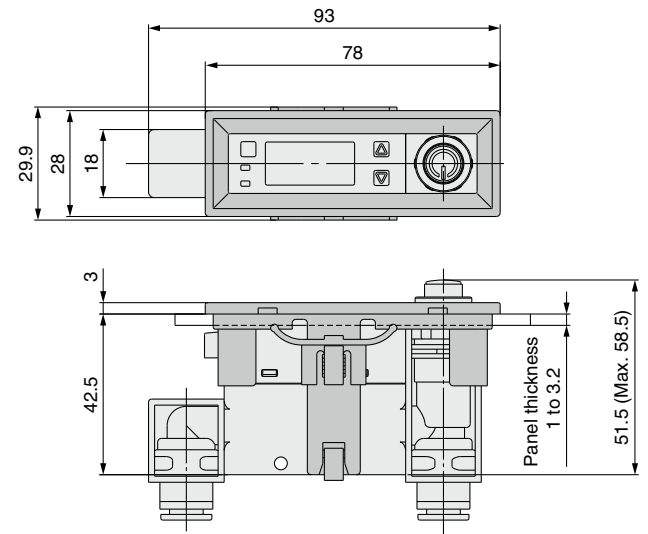

Panel Fitting Dimensions

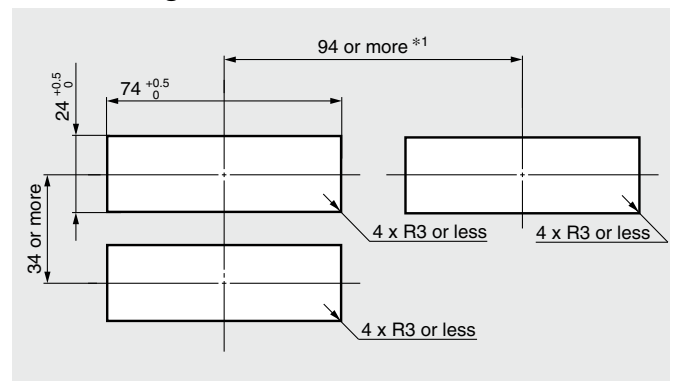

Panel thickness 1 to 3.2 mm

*1 Piping entry direction: Minimum dimensions for bottom piping. If using straight piping, the piping material and tubing need to be taken into consideration when designing the system. If a bend (R) is used, limit it to R3 or less.

Dimensions

PFMB7201

With bracket/Without flow adjustment valve

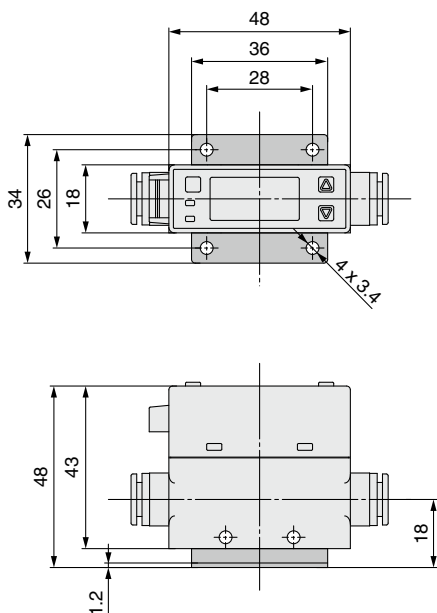

With bracket/With flow adjustment valve

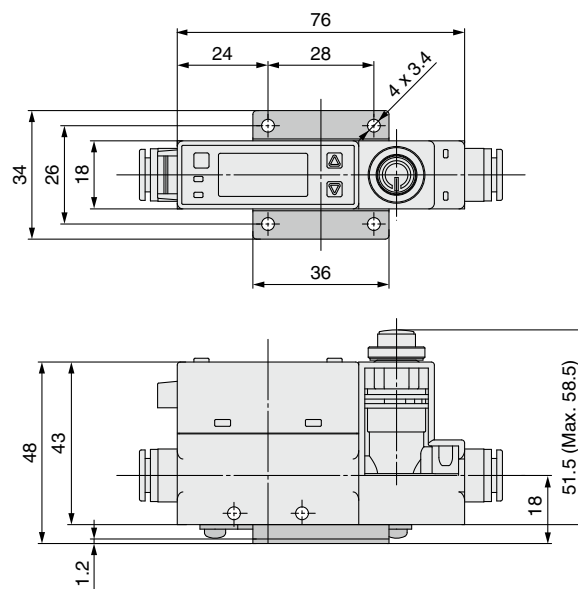

DIN rail mounting

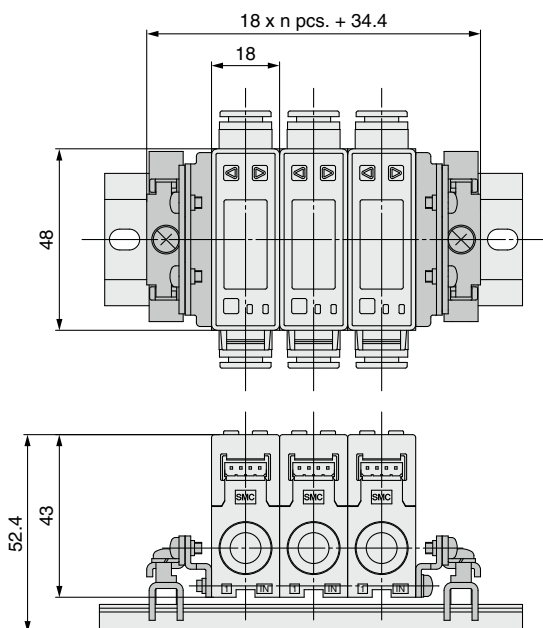

- The DIN rail should be provided by the customer.
- The DIN rail is not suitable for port size F02 (G1/4).

PFMB

PFGB300

Function
Details

PFMB7 Series

Dimensions

PFMB7501/7102/7202

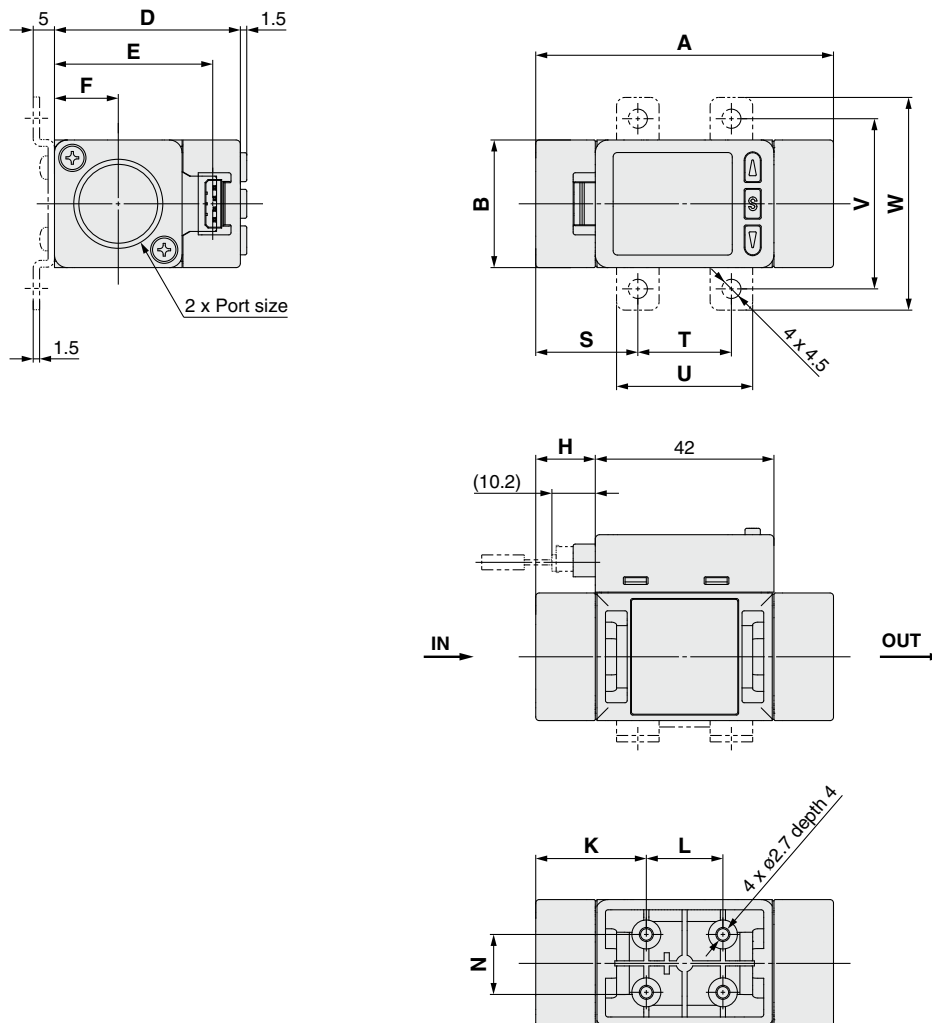

Model	Symbol	A	B	D	E	F	H	K	L	N
PFMB7501/7102		70	30	43.7	37.2	15	14	26	18	13.6
PFMB7202		90	35	49.2	42.7	17.5	24	31	28	16.8

Model	Symbol	Bracket dimensions				
		S	T	U	V	W
PFMB7501/7102		24	22	32	40	50
PFMB7202		30	30	42	48	58

Lead wire with connector (Part no.: ZS-33-D)

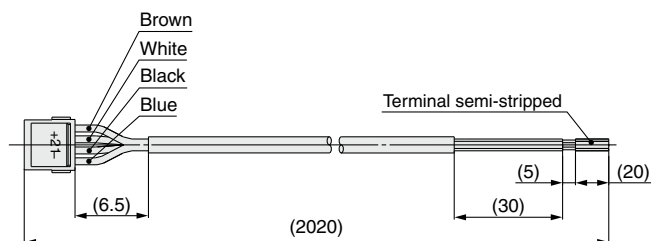

Cable Specifications

Conductor	Nominal cross section	AWG26
	Outside diameter	Approx. 0.50 mm
Insulator	Outside diameter	Approx. 1.00 mm
	Color	Brown, White, Black, Blue
Sheath	Material	Oil-resistant PVC
Finished outside diameter		ø3.5

* For wiring, refer to the "Operation Manual" on the SMC website.
Documents/Download --> Instruction Manuals

3-Screen Display

Digital Flow Monitor

PFG300 Series



PFMB

PFG300

Function Details

How to Order

PFG 3 0 0 - RT - M - L [] [] []

Type

3 Remote type monitor unit

Input specification

Symbol	Description	Applicable flow switch model
0	Voltage input	PFMB7□-C/E series
1	Current input	PFMB7□-D/F series

Output specification

RT	2 outputs (NPN/PNP switching type) + Analog voltage output*1, 2
SV	2 outputs (NPN/PNP switching type) + Analog current output*2
XY	2 outputs (NPN/PNP switching type) + Copy function

*1 Can switch between 1 to 5 V and 0 to 10 V

*2 Can be switched to external input or copy function

Unit specification

Nil	Units selection function*3
M	SI unit only*4

*3 This product is for overseas use only according to the New Measurement Act. (The SI unit type is provided for use in Japan.)

*4 Fixed unit: Instantaneous flow: L/min
Accumulated flow: L

Option 4

	Operation manual	Calibration certificate
Nil	○	—
Y	—	○
K	○	○
T	—	○

Option 3

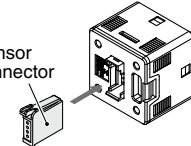
Nil	None
F	ZS-28-C-1 

Option 1

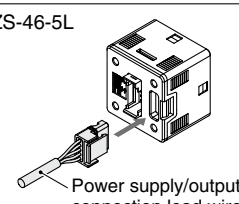
Symbol	Description
Nil	Without lead wire
L	Power supply/output connection lead wire (Lead wire length: 2 m) 

Option 2

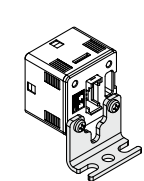
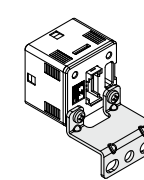
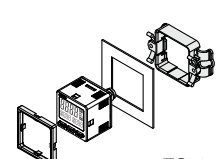
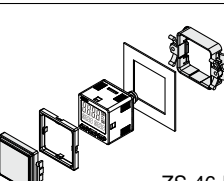
Symbol	Description
Nil	None
A1	Bracket A (Vertical mounting)  ZS-46-A1
A2	Bracket B (Horizontal mounting)  ZS-46-A2
B	Panel mount adapter  ZS-46-B
D	Panel mount adapter + Front protection cover  ZS-46-D

Options/Part Nos.

When only optional parts are required, order with the part numbers listed below.

Part no.	Option	Note
ZS-28-C-1	Sensor connector	For PFMB
ZS-46-A1	Bracket A	Tapping screw: Nominal size 3 x 8 L (2 pcs.)
ZS-46-A2	Bracket B	Tapping screw: Nominal size 3 x 8 L (2 pcs.)
ZS-46-B	Panel mount adapter	
ZS-46-D	Panel mount adapter + Front protection cover	
ZS-46-5L	Power supply/output connection lead wire	5-core, 2 m
ZS-27-01	Front protection cover	

Connection Example

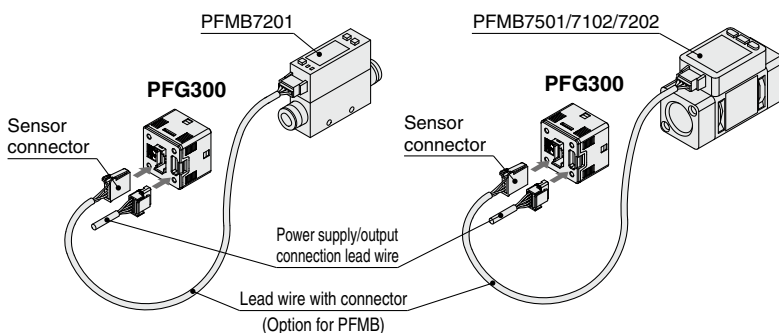

PF300 Series

For flow switch precautions and specific product precautions, refer to the "Operation Manual" on the SMC website.

Specifications

Model		PF300 series				
Applicable SMC flow switch	Model	PFMB7201	PFMB7501	PFMB7102	PFMB7202	
	Rated flow range*1	2 to 200 L/min	5 to 500 L/min	10 to 1000 L/min	20 to 2000 L/min	
Flow	Set point range	Instantaneous flow	-10 to 210 L/min	-25 to 525 L/min	-50 to 1050 L/min	-100 to 2100 L/min
		Accumulated flow	0 to 999,999,999,999 L	0 to 999,999,999,990 L		
	Smallest settable increment	Instantaneous flow	1 L/min			
		Accumulated flow	1 L	10 L		
	Accumulated volume per pulse (Pulse width = 50 ms)	1 L/pulse			10 L/pulse	
Accumulated value hold function*3	Intervals of 2 or 5 minutes can be selected. The stored accumulated flow is held even when the power supply is OFF.					
Electrical	Power supply voltage	12 to 24 VDC ±10%				
	Current consumption	25 mA or less				
	Protection	Polarity protection				
Accuracy	Display accuracy	±0.5% F.S. ± Minimum display unit (Ambient temperature of 25°C)				
	Analog output accuracy	±0.5% F.S. (Ambient temperature of 25°C)				
	Repeatability	±0.1% F.S. ± Minimum display unit				
	Temperature characteristics	±0.5% F.S. (Ambient temperature: 0 to 50°C, 25°C standard)				
Switch output	Output type	Select from NPN or PNP open collector output.				
	Output mode	Select from Hysteresis, Window comparator, Accumulated output, Accumulated pulse output, Error output, or Switch output OFF modes.				
	Switch operation	Select from Normal or Reversed output.				
	Max. load current	80 mA				
	Max. applied voltage (NPN only)	30 VDC				
	Internal voltage drop (Residual voltage)	NPN output: 1 V or less (at load current of 80 mA), PNP output: 1.5 V or less (at load current of 80 mA)				
	Response time*2	3 ms or less				
	Delay time*2	Select from 0.00, 0.05 to 0.1 s (increment of 0.01 s), 0.1 to 1.0 s (increment of 0.1 s), 1 to 10 s (increment of 1 s), 20 s, 30 s, 40 s, 50 s, or 60 s				
	Hysteresis*4	Variable from 0				
Analog output*5	Protection	Short circuit protection				
	Output type	Voltage output: 1 to 5 V, 0 to 10 V (only when the power supply voltage is 24 VDC) Current output: 4 to 20 mA (0 L/min to maximum value of the rated flow)				
	Impedance	Voltage output	Output impedance: 1 kΩ			
		Current output	Maximum load impedance: 300 Ω (at power supply voltage of 12 V), 600 Ω (at power supply voltage of 24 VDC)			
Response time*2	50 ms or less					
External input*6	External input	Input voltage: 0.4 V or less (Reed or Solid state) for 30 ms or longer				
	Input mode	Select from Accumulated value external reset or Peak/Bottom value reset.				
Sensor input	Input type	Voltage input: 1 to 5 VDC (Input impedance: 1 MΩ), Current input: 4 to 20 mA DC (Input impedance: 51 Ω) (0 L/min to maximum value of the rated flow)				
	Connection method	Connector (e-CON)				
	Protection	Over voltage protection (Up to 26.4 VDC)				
Display	Display mode	Select from Instantaneous flow or Accumulated flow.				
	Unit*7	Instantaneous flow	L/min, cfm (ft ³ /min)			
		Accumulated flow	L, ft ³ , L x 10 ⁶ , ft ³ x 10 ⁶			
	Display range	Instantaneous flow	-10 to 210 L/min	-25 to 525 L/min	-50 to 1050 L/min	-100 to 2100 L/min
		Accumulated flow*9	0 to 999,999,999,999 L	0 to 999,999,999,990 L		
	Minimum display unit	Instantaneous flow	1 L/min			
		Accumulated flow	1 L	10 L		
	Display type	LCD				
	Number of displays	3-screen display (Main screen, Sub screen)				
Display color	1) Main screen: Red/Green, 2) Sub screen: Orange					
Number of display digits	1) Main screen: 5 digits (7 segments), 2) Sub screen: 9 digits (7 segments)					
Indicator LED	LED ON when switch output is ON OUT1/2: Orange					
Digital filter*8	Select from 0.00, 0.05 to 0.1 s (increment of 0.01 s), 0.1 to 1.0 s (increment of 0.1 s), 1 to 10 s (increment of 1 s), 20 s, or 30 s					
Environment	Enclosure	IP40				
	Withstand voltage	1000 VAC for 1 minute between terminals and housing				
	Insulation resistance	50 MΩ or more (500 VDC measured via megohmmeter) between terminals and housing				
	Operating temperature range	Operating: 0 to 50°C, Stored: -10 to 60°C (No condensation or freezing)				
Operating humidity range	Operating/Stored: 35 to 85% RH (No condensation or freezing)					
Standards	CE, RoHS					
Weight	Body	25 g (Excluding the power supply/output connection lead wire)				
	Lead wire with connector	+39 g				

*1 Rated flow range of the applicable flow switch

*2 Value without digital filter (at 0.00 s)

*3 When using the accumulated value hold function, use the operating conditions to calculate the product life, and do not exceed it. The maximum access limit of the memory device is 1.5 million times. If the product is operated 24 hours per day, the product life will be as follows:

- 5 min interval: life is calculated as 5 min x 1.5 million = 7.5 million min = 14.3 years
- 2 min interval: life is calculated as 2 min x 1.5 million = 3 million min = 5.7 years

If the accumulated value external reset is repeatedly used, the product life will be shorter than the calculated life.

*4 If the flow fluctuates around the set value, the width for setting more than the fluctuating width needs to be set. Otherwise, chattering will occur.

*5 Setting is only possible for models with analog output.

*6 Setting is only possible for models with external input.

*7 Setting is only possible for models with the units selection function.

*8 The response time indicates when the set value is 90% in relation to the step input.

*9 The accumulated flow display is the upper 6-digit and lower 6-digit (total of 12 digits) display. When the upper digits are displayed, x 10⁶ lights up.

* Products with tiny scratches, marks, or display color or brightness variations which do not affect the performance of the product are verified as conforming products.

Internal Circuits and Wiring Examples

**-XY
-RT
-SV
NPN (2 outputs) + Copy function**

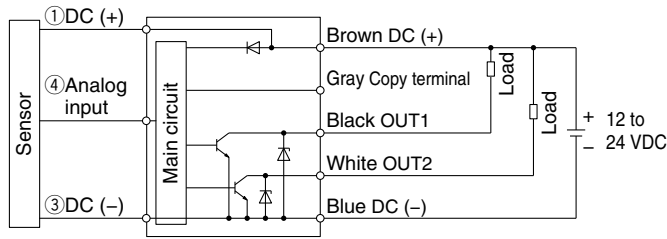

**-XY
-RT
-SV
PNP (2 outputs) + Copy function**

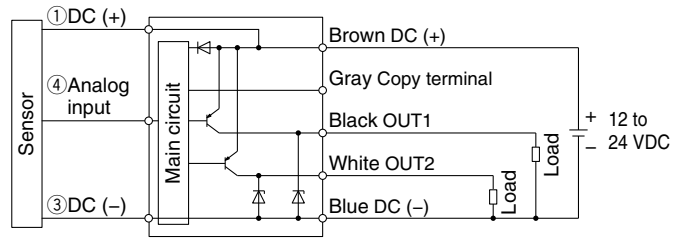

**-RT: NPN (2 outputs) + Analog voltage output
-SV: NPN (2 outputs) + Analog current output**

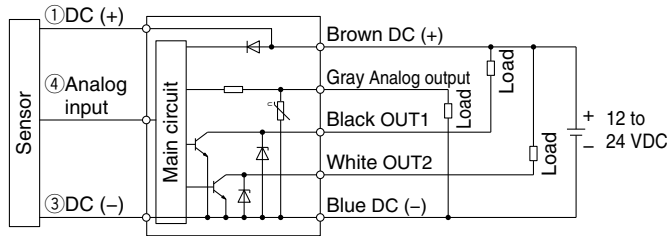

**-RT: PNP (2 outputs) + Analog voltage output
-SV: PNP (2 outputs) + Analog current output**

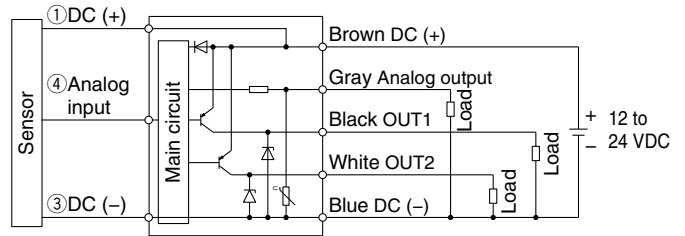

**-RT: NPN (2 outputs) + External input
-SV: NPN (2 outputs) + External input**

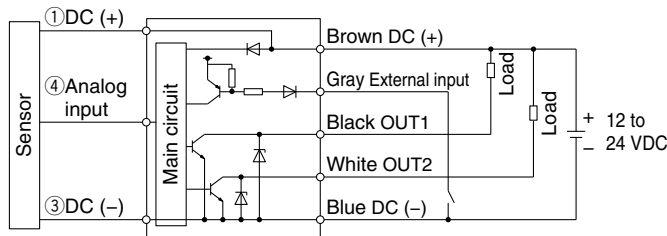

**-RT: PNP (2 outputs) + External input
-SV: PNP (2 outputs) + External input**

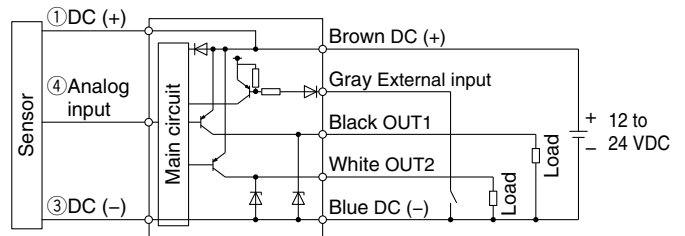

Accumulated pulse output wiring examples

NPN (2 outputs) type

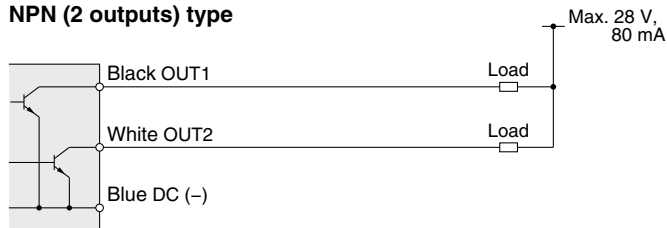

PNP (2 outputs) type

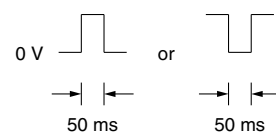
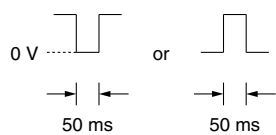
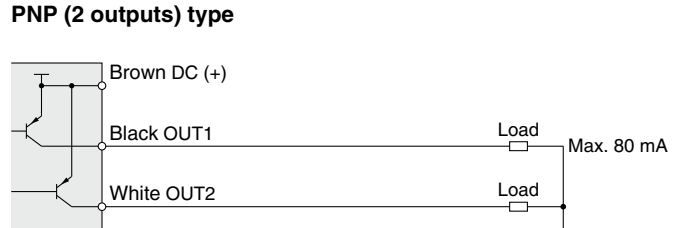

PFMB

PFG300

Function Details

PFG300 Series

Dimensions

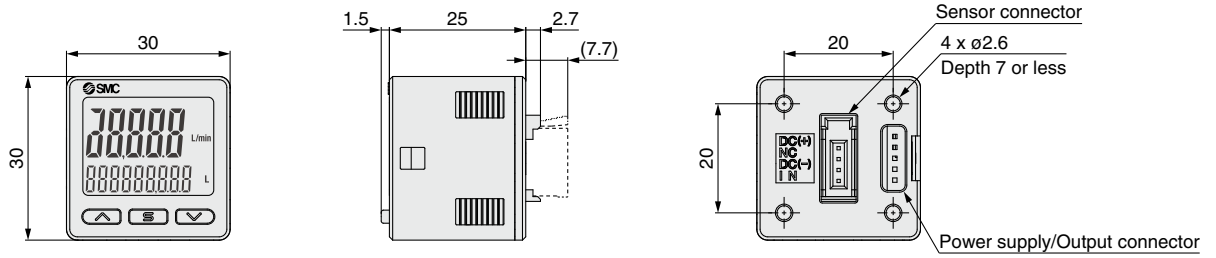

Bracket A (Part no.: ZS-46-A1)

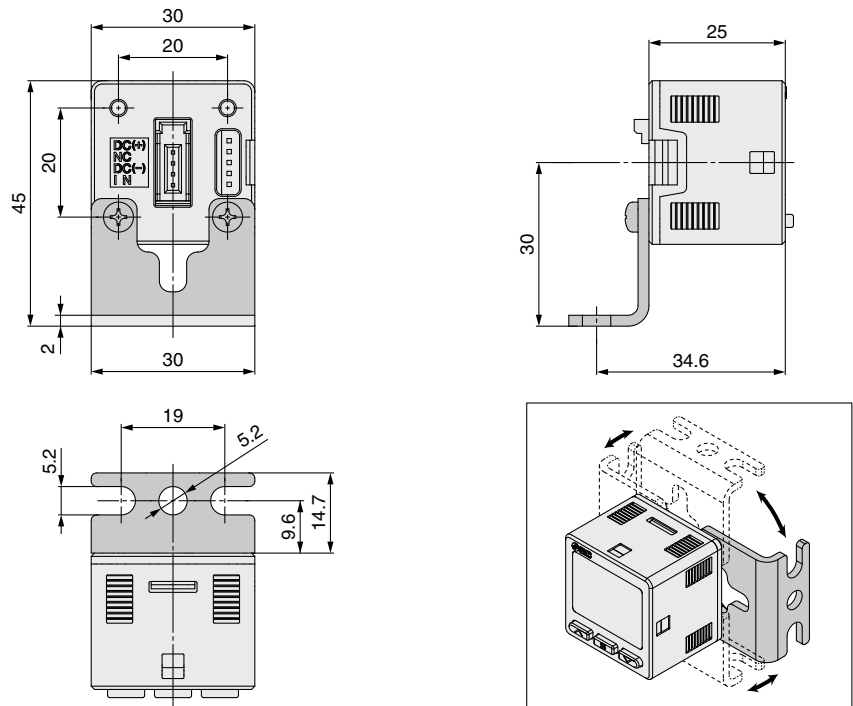

* Bracket configuration allows for mounting in four orientations.

Bracket B (Part no.: ZS-46-A2)

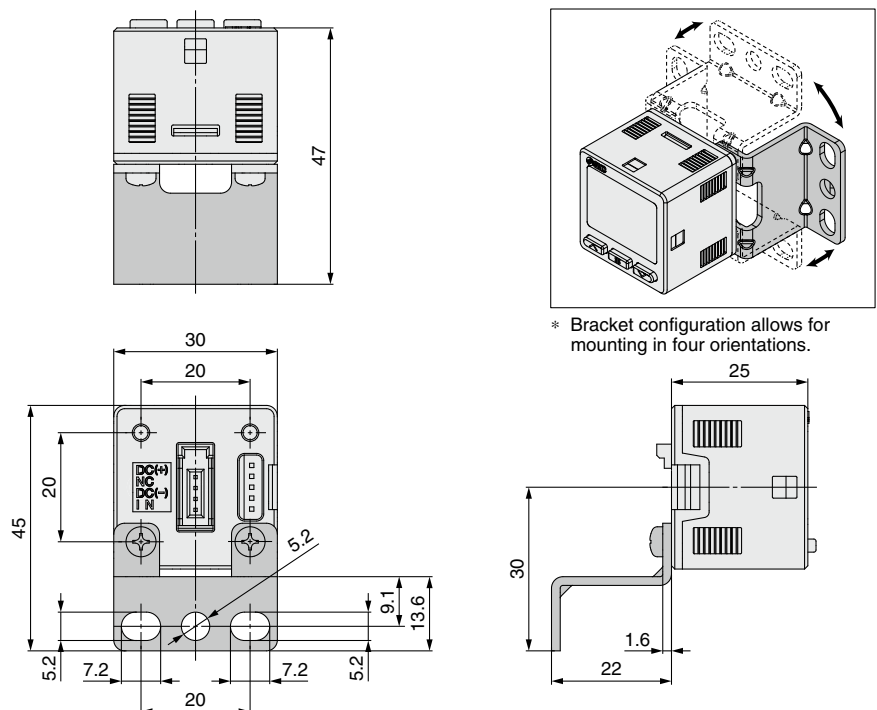

* Bracket configuration allows for mounting in four orientations.

Dimensions

Panel mount adapter (Part no.: ZS-46-B)

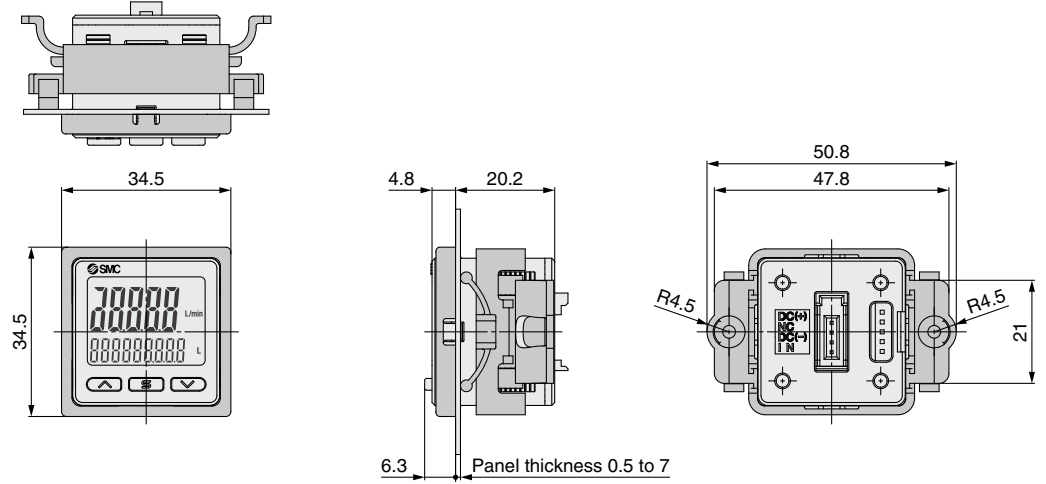

Panel mount adapter + Front protection cover (Part no.: ZS-46-D)

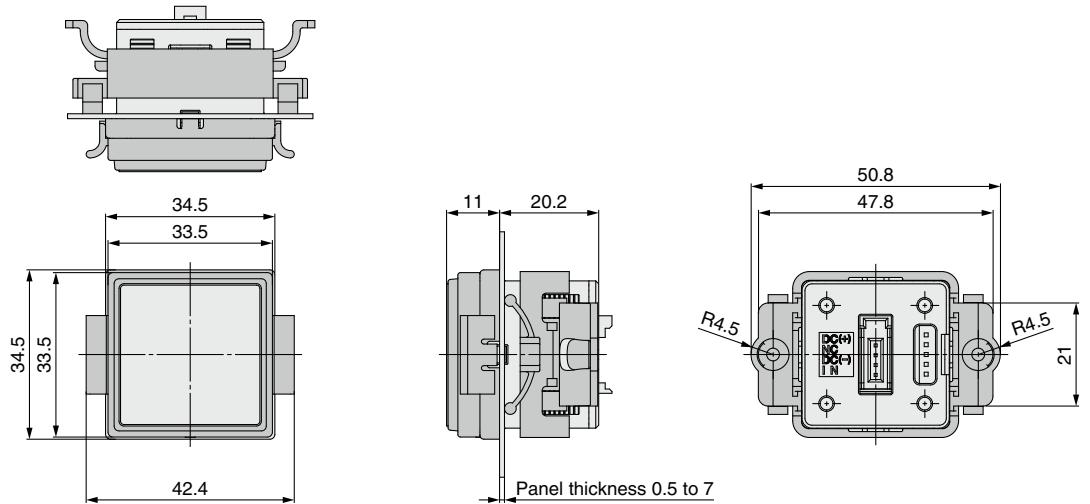

Power supply/output connection lead wire (Part no.: ZS-46-5L)

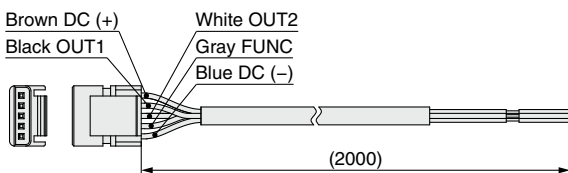

Sensor connector (Part no.: ZS-28-C-1)

Pin no.	Terminal
1	DC (+)
2	N.C.
3	DC (-)
4	IN*1

*1 1 to 5 V or 4 to 20 mA

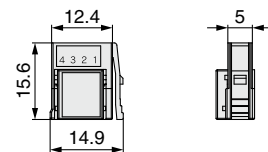

Cable Specifications

Conductor cross section	0.15 mm ² (AWG26)	
Insulator	Outside diameter	1.0 mm
	Color	Brown, Blue, Black, White, Gray (5-core)
Sheath	Finished outside diameter	ø3.5

PFG300 Series

Dimensions

Panel fitting dimensions

Individual mounting

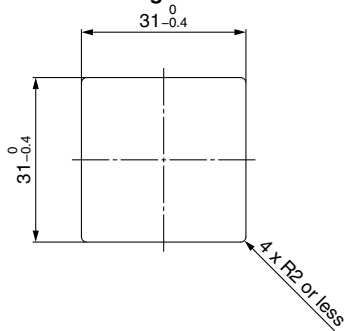

Multiple (2 pcs. or more) secure mounting <Horizontal>

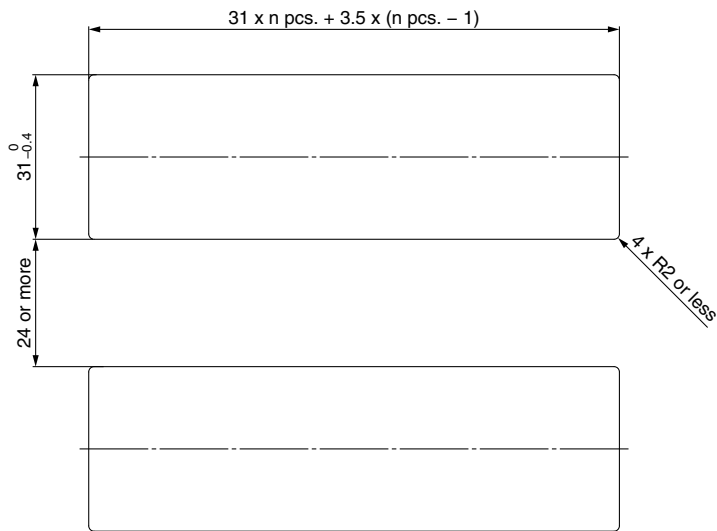

Panel mount example <Horizontal>

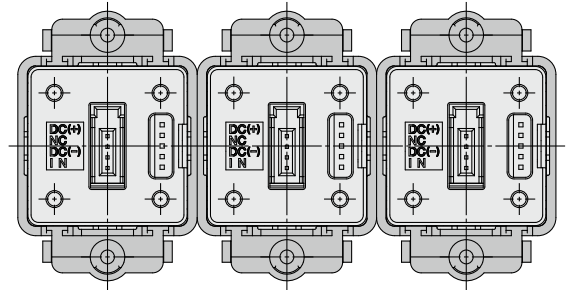

<Vertical>

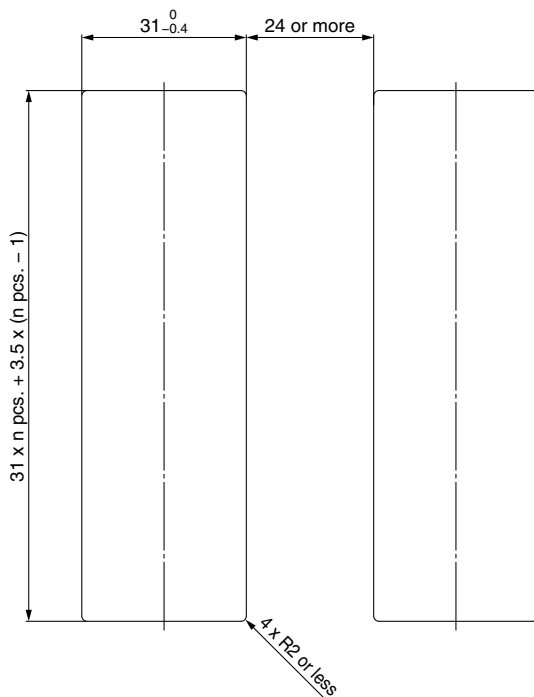

Panel mount example <Vertical>

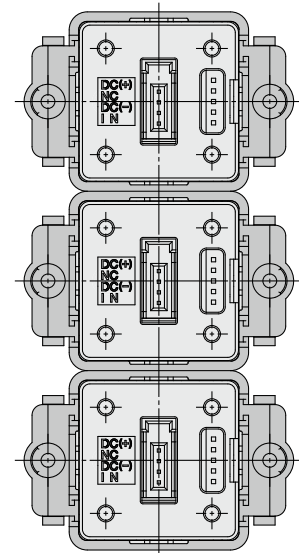

PFMB Series

Function Details

Output operation

The output operation can be selected from the following:
Output (hysteresis mode and window comparator mode) corresponding to instantaneous flow or output (accumulated output and pulse output) corresponding to accumulated flow.

(Default setting: Hysteresis mode, Normal output)

Display color

The display color can be selected for each output condition. The selection of the display color provides visual identification of abnormal values. (The display color depends on OUT1 setting.)

Green for ON, Red for OFF
Red for ON, Green for OFF
Red all the time
Green all the time

Reference condition

The display unit can be selected from standard condition or normal condition.

Standard condition: Flow rate converted to a volume at 20°C and 1 atm (atmosphere)
Normal condition: Flow rate converted to a volume at 0°C and 1 atm (atmosphere)

Display mode

The display mode can be selected from instantaneous flow or accumulated flow.

Instantaneous flow display
Accumulated flow display

Response time

The response time can be selected to suit the application. (Default setting: 1 s) Abnormalities can be detected more quickly by setting the response time to 0.05 seconds. The effect of fluctuation and flickering of the display can be reduced by setting the response time to 2 seconds.

0.05 s
0.1 s
0.5 s
1 s
2 s

Display OFF mode

This function will turn the display OFF. In this mode, decimal points flash on the main screen. If any button is pressed during this mode, the display reverts to normal for 30 seconds to allow checking of the flow, etc.

Setting of security code

The user can select whether a security code must be entered to release the key lock. At a time of shipment from the factory, it is set such that a security code is not required.

External input function

This function can be used only when the optional external input is present. The accumulated flow, peak value, and bottom value can be reset remotely.

Accumulated value external reset: A function to reset the accumulated flow value when an external input signal is applied.
In accumulated increment mode, the accumulated value will reset to and increase from zero.
In accumulated decrement mode, the accumulated value will reset to and decrease from the set value.

* When the accumulated value is stored to memory, every time the accumulated value external reset is activated, the memory (EEPROM) will be accessed. Take into consideration that the maximum number of times the memory can be accessed is 1 million times. The total number of external inputs and the accumulated value memorizing time interval should not exceed 1 million times.

Peak/Bottom value reset: Peak and bottom value are reset.

Forced output function

The output is turned on/off in a fixed state when starting the system or during maintenance. This enables confirmation of wiring and prevents system errors due to unexpected output.
For the analog output type, when ON the output will be 5 V or 20 mA, and when OFF, it will be 1 V or 4 mA.

* Also, an increase or decrease of the flow and temperature will not change the on/off status of the output while the forced output function is activated.

Accumulated value hold

The accumulated value is not cleared even when the power supply is turned off. The accumulated value is memorized every 2 or 5 minutes during measurement and continues from the last memorized value when the power supply is turned on again.

The life time of the memory device is 1 million access times. Take this into consideration before using this function.

Peak/Bottom value display

The maximum (minimum) flow rate is detected and updated from when the power supply is turned on. In peak (bottom) value display mode, this maximum (minimum) flow rate is displayed.

Keylock function

Prevents operation errors such as accidentally changing setting values

Analog output free range function

This function allows a flow that generates an output of 5 V or 20 mA to be changed. The value can be changed between 10% of the maximum value of the rated flow and the maximum value of the display range.

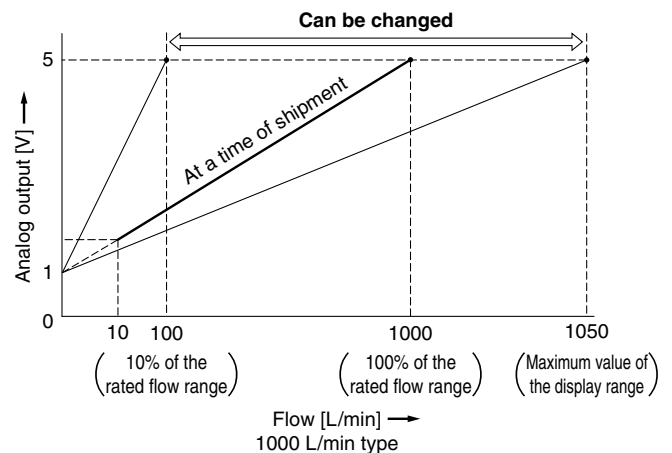

Reversible display mode

When the switch is used upside down, the orientation of the display can be rotated to make it easier to read by using the reversible display function.

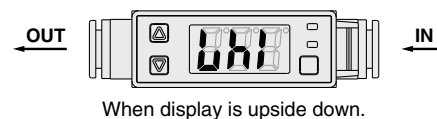

Reversible display function

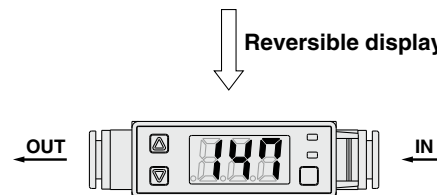

Reset to the default settings

The product can be returned to its factory default settings.

PFMB Series

■ Error display function

When an error or abnormality arises, the location and contents are displayed.

Display	Error name	Description	Action	
Er1	OUT1 over current error	A load current of 80 mA or more is applied to the switch output (OUT1).	Eliminate the cause of the over current by turning off the power supply and then turning it on again.	
Er2	OUT2 over current error	A load current of 80 mA or more is applied to the switch output (OUT2).		
HHH	Instantaneous flow error	The flow rate exceeds the maximum value of the display range.	Decrease the flow rate.	
LLL	Reverse flow error	There is a reverse flow equivalent to -5% or more.	Change the flow to the correct direction.	
999999999 ("999" will flash in any of upper, middle, lower 3-digit displays.)	PFMB7201 PFMB7501 PFMB7102	Accumulated flow error	The flow rate exceeds the accumulated flow rate range.	Clear the accumulated flow rate.
Er0	System error	Internal data error	Turn the power off and then on again.	
Er4				
Er6				
Er8				

If the error cannot be solved after the instructions above are performed, please contact SMC for investigation.

⚠ Precautions on piping

Piping for the metal attachment

- Tighten to the specified torque. Refer to the table below for the required torque values.
- Use a wrench suited for the required torque. Do not use an extremely large wrench (Total length of 40 cm or more).
- If the tightening torque is exceeded, the product can be broken.
If the tightening torque is insufficient, the fitting may become loose.
- Avoid any sealant tape getting inside the flow path.
- Ensure there is no leakage after piping.
- When mounting the fitting, a wrench should be used on the metal part (attachment) of the fitting only.
Holding other parts of the product with a wrench may damage the product.
Specifically, make sure that the wrench does not damage the connector.

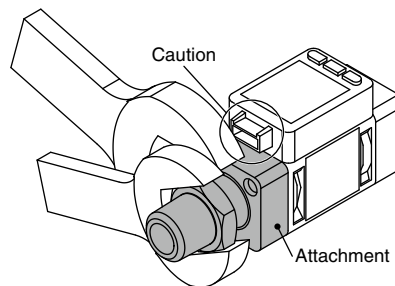
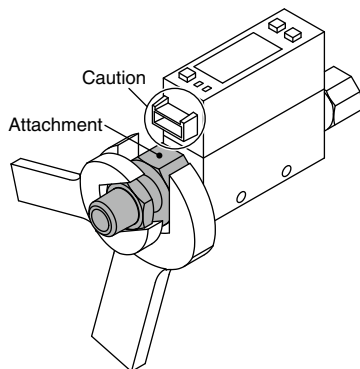

Model	Required torque
PFMB7201	12 to 14 N·m
PFMB7501	28 to 30 N·m
PFMB7102	
PFMB7202	

Model	Nominal thread size	Width across flats of attachment
PFMB7201	Rc1/4, NPT1/4	17 mm
	G1/4	21 mm
PFMB7501	1/2	30 mm
PFMB7102		35 mm
PFMB7202	3/4	35 mm

PFG300 Series

Function Details

Output operation

The output operation can be selected from the following:
Output (hysteresis mode and window comparator mode) corresponding to instantaneous flow or output (accumulated output and pulse output) corresponding to accumulated flow.

(Default setting: Hysteresis mode, Normal output)

Simple setting mode

Only the set values for instantaneous flow and accumulated flow can be changed. Output mode, output type, display color, and accumulate pulse output cannot be changed.

Display color

The display color can be selected for each output condition. The selection of the display color provides visual identification of abnormal values.

Green for ON, Red for OFF
Red for ON, Green for OFF
Red all the time
Green all the time

Delay time setting

The time from when the instantaneous flow reaches the set value to when the switch output operates can be set. Setting the delay time can prevent the switch output from chattering.

(Default setting: 0 s)

0.00 s
0.05 to 0.1 s (increment of 0.01 s)
0.1 to 1.0 s (increment of 0.1 s)
1 to 10 s (increment of 1 s)
20 s
30 s
40 s
50 s
60 s

Digital filter setting

The time for the digital filter can be set to the sensor input. Setting the digital filter can reduce chattering of the switch output and flickering of the analog output and the display.

The response time indicates when the set value is 90% in relation to the step input.

(Default setting: 0 s)

0.00 s
0.05 to 0.1 s (increment of 0.01 s)
0.1 to 1.0 s (increment of 0.1 s)
1 to 10 s (increment of 1 s)
20 s
30 s

FUNC output switching function

Analog output, external input, or copy function can be selected.

(Default setting: Analog output)

Selectable analog output function

1 to 5 V or 0 to 10 V can be selected for the analog voltage output type.

(Default setting: 1 to 5 V)

External input function

The accumulated flow, peak value, and bottom value can be reset remotely.

Accumulated value external reset: A function to reset the accumulated flow value when an external input signal is applied.

In accumulated increment mode, the accumulated value will reset to and increase from zero.

In accumulated decrement mode, the accumulated value will reset to and decrease from the set value.

* When the accumulated value is stored to memory, every time the accumulated value external reset is activated, the memory will be accessed. Take into consideration that the maximum number of times the memory can be accessed is 1.5 million times. The total number of external inputs and the accumulated value memorizing time interval should not exceed 1.5 million times.

Peak/Bottom value reset: Peak and bottom value are reset.

Forced output function

The output is turned on/off in a fixed state when starting the system or during maintenance. This enables the confirmation of wiring and prevents system errors due to unexpected output.

For the analog output type: When ON, the output will be 5 V (or 10 V when 0 to 10 V is selected) or 20 mA, and when OFF, 1 V (or 0 V when 0 to 10 V is selected) or 4 mA.

* Also, an increase or decrease of the flow will not change the on/off status of the output while the forced output function is activated.

Accumulated value hold

The accumulated value is not cleared even when the power supply is turned off. The accumulated value is memorized every 2 or 5 minutes during measurement and continues from the last memorized value when the power supply is turned on again.

The maximum writable limit of the memory device is 1.5 million times, which should be taken into consideration.

Peak/Bottom value display

The maximum (minimum) flow rate is detected and updated from when the power supply is turned on. In peak (bottom) value display mode, this maximum (minimum) flow rate is displayed.

Setting of security code

The user can select whether a security code must be entered to release the key lock. At a time of shipment from the factory, it is set such that a security code is not required.

Keylock function

Prevents operation errors such as accidentally changing setting values

Reset to the default settings

The product can be returned to its factory default settings.

Display with zero cut-off setting

When the flow is close to 0 L/min, the product will round the value down and zero will be displayed. A flow value may be displayed even when the flow rate is 0 L/min due to high pressure or depending on the installation. The zero cut function will force the display to zero. The range to display zero can be changed.

PFG300 Series

■ Selection of display on sub screen

The display on the sub screen in measuring mode can be set.

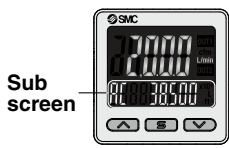

Set value display	Accumulated value display	Peak value display
Displays the set value 	Displays the accumulated value 	Displays the peak value
Bottom value display	Line name display	OFF
Displays the bottom value 	Displays the line name (Up to 5 alphanumeric characters can be input.) 	Displays nothing

■ Analog output free range function

This function allows a flow that generates an output of 5 V (or 10 V when 0 to 10 V is selected) or 20 mA to be changed. The value can be changed between 10% of the maximum value of the rated flow and the maximum value of the display range.

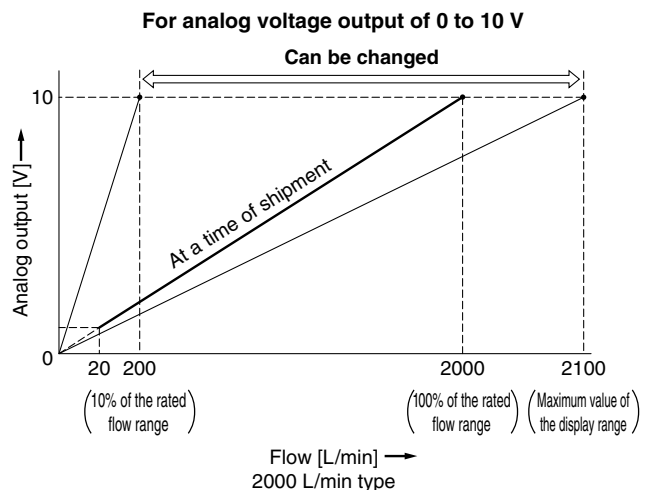
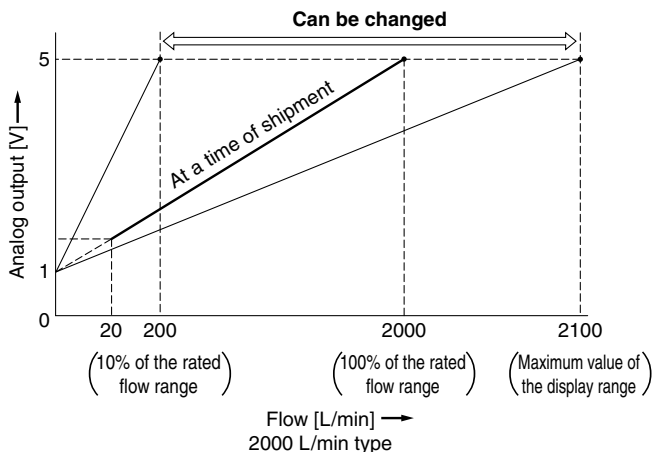

■ Error display function

When an error or abnormality arises, the location and contents are displayed.

Display	Error name	Description	Action
Er 1 Er 2	OUT over current error	A load current of 80 mA or more is applied to the switch output (OUT).	Eliminate the cause of the over current by turning off the power supply and then turning it on again.
HHH	Instantaneous flow error	The flow rate exceeds the maximum value of the display range.	Decrease the flow rate.
LLL	Reverse flow error	There is a reverse flow equivalent to -5% or more.	Change the flow to the correct direction.
999999 flashes x 10 ⁶	Accumulated flow error	The flow rate exceeds the accumulated flow rate range.	Clear the accumulated flow rate.
Er 0 Er 4 Er 6 Er 7 Er 8 Er 14 Er 40	System error	Internal data error	Turn the power off and then on again.
Er 13	Copy error	The copy function does not operate properly.	After clearing the error by pressing the and buttons simultaneously for a minimum of 1 second, check the wiring and the model, and then attempt to copy again.

If the error cannot be solved after the instructions above are performed, please contact SMC for investigation.

■ **Copy function**

The settings of the master monitor can be copied to the slave monitors, reducing setting labor and minimizing the risk of setting mistakes.

The set value can be copied to up to 10 flow monitors simultaneously.
 (Maximum transmission distance: 4 m)

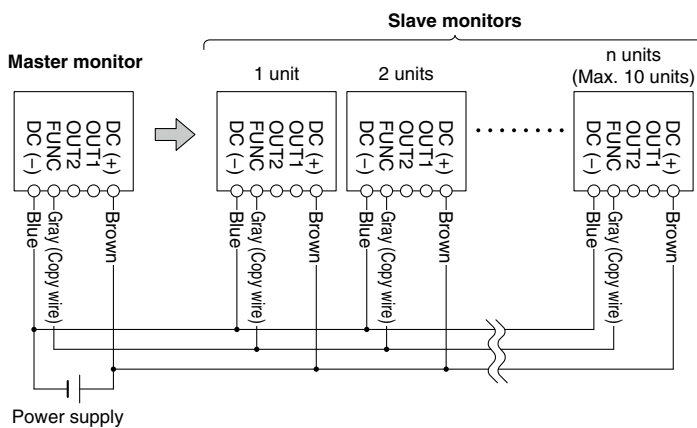
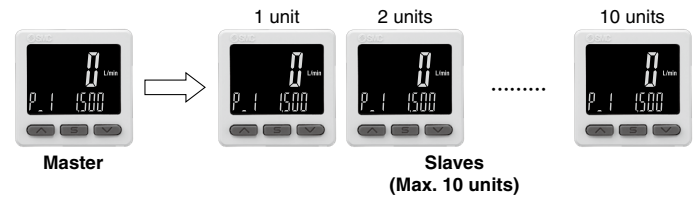

- 1) Wire as shown in the figure on the left.
- 2) Select the slave monitor which is to be the master, and change it into a master using the buttons. (In the default setting, all flow monitors are set as slaves.)
- 3) Press the **S** button on the master monitor to start copying.

■ **Selection of power saving mode**

Power saving mode can be selected.

It shifts to the power saving mode without button operation for 30 seconds.

It is set to the normal mode (Power saving mode is OFF.) at a time of shipment from the factory.

(During power saving mode, [ECo] will flash in the sub screen and the operation light is ON (only when the switch is ON).)

* There may be a difference in the displayed value on the connected flow switch and the flow monitor. When the flow monitor display is being used, it is recommended to set the flow switch display to OFF mode.

Safety Instructions

These safety instructions are intended to prevent hazardous situations and/or equipment damage. These instructions indicate the level of potential hazard with the labels of “**Caution**,” “**Warning**” or “**Danger**.” They are all important notes for safety and must be followed in addition to International Standards (ISO/IEC)*1), and other safety regulations.

 **Caution:** **Caution** indicates a hazard with a low level of risk which, if not avoided, could result in minor or moderate injury.

 **Warning:** **Warning** indicates a hazard with a medium level of risk which, if not avoided, could result in death or serious injury.

 **Danger :** **Danger** indicates a hazard with a high level of risk which, if not avoided, will result in death or serious injury.

*1) ISO 4414: Pneumatic fluid power – General rules relating to systems.
ISO 4413: Hydraulic fluid power – General rules relating to systems.
IEC 60204-1: Safety of machinery – Electrical equipment of machines.
(Part 1: General requirements)
ISO 10218-1: Manipulating industrial robots – Safety.
etc.

Warning

1. The compatibility of the product is the responsibility of the person who designs the equipment or decides its specifications.

Since the product specified here is used under various operating conditions, its compatibility with specific equipment must be decided by the person who designs the equipment or decides its specifications based on necessary analysis and test results. The expected performance and safety assurance of the equipment will be the responsibility of the person who has determined its compatibility with the product. This person should also continuously review all specifications of the product referring to its latest catalog information, with a view to giving due consideration to any possibility of equipment failure when configuring the equipment.

2. Only personnel with appropriate training should operate machinery and equipment.

The product specified here may become unsafe if handled incorrectly. The assembly, operation and maintenance of machines or equipment including our products must be performed by an operator who is appropriately trained and experienced.

3. Do not service or attempt to remove product and machinery/equipment until safety is confirmed.

1. The inspection and maintenance of machinery/equipment should only be performed after measures to prevent falling or runaway of the driven objects have been confirmed.
2. When the product is to be removed, confirm that the safety measures as mentioned above are implemented and the power from any appropriate source is cut, and read and understand the specific product precautions of all relevant products carefully.
3. Before machinery/equipment is restarted, take measures to prevent unexpected operation and malfunction.

4. Contact SMC beforehand and take special consideration of safety measures if the product is to be used in any of the following conditions.

1. Conditions and environments outside of the given specifications, or use outdoors or in a place exposed to direct sunlight.
2. Installation on equipment in conjunction with atomic energy, railways, air navigation, space, shipping, vehicles, military, medical treatment, combustion and recreation, or equipment in contact with food and beverages, emergency stop circuits, clutch and brake circuits in press applications, safety equipment or other applications unsuitable for the standard specifications described in the product catalog.
3. An application which could have negative effects on people, property, or animals requiring special safety analysis.
4. Use in an interlock circuit, which requires the provision of double interlock for possible failure by using a mechanical protective function, and periodical checks to confirm proper operation.

Caution

1. The product is provided for use in manufacturing industries.

The product herein described is basically provided for peaceful use in manufacturing industries.
If considering using the product in other industries, consult SMC beforehand and exchange specifications or a contract if necessary.
If anything is unclear, contact your nearest sales branch.

Limited warranty and Disclaimer/ Compliance Requirements

The product used is subject to the following “Limited warranty and Disclaimer” and “Compliance Requirements”.

Read and accept them before using the product.

Limited warranty and Disclaimer

1. The warranty period of the product is 1 year in service or 1.5 years after the product is delivered, whichever is first.*2)
Also, the product may have specified durability, running distance or replacement parts. Please consult your nearest sales branch.
2. For any failure or damage reported within the warranty period which is clearly our responsibility, a replacement product or necessary parts will be provided.
This limited warranty applies only to our product independently, and not to any other damage incurred due to the failure of the product.
3. Prior to using SMC products, please read and understand the warranty terms and disclaimers noted in the specified catalog for the particular products.

*2) Vacuum pads are excluded from this 1 year warranty.

A vacuum pad is a consumable part, so it is warranted for a year after it is delivered.
Also, even within the warranty period, the wear of a product due to the use of the vacuum pad or failure due to the deterioration of rubber material are not covered by the limited warranty.

Compliance Requirements

1. The use of SMC products with production equipment for the manufacture of weapons of mass destruction (WMD) or any other weapon is strictly prohibited.
2. The exports of SMC products or technology from one country to another are governed by the relevant security laws and regulations of the countries involved in the transaction. Prior to the shipment of a SMC product to another country, assure that all local rules governing that export are known and followed.

Caution

SMC products are not intended for use as instruments for legal metrology.

Measurement instruments that SMC manufactures or sells have not been qualified by type approval tests relevant to the metrology (measurement) laws of each country. Therefore, SMC products cannot be used for business or certification ordained by the metrology (measurement) laws of each country.

Revision History

Edition B	* 20 to 2000 L type has been added.	TS
Edition C	* The digital flow monitor PFG300 series has been added. * Number of pages has been increased from 24 to 36.	VZ

Safety Instructions

Be sure to read the “Handling Precautions for SMC Products” (M-E03-3) and “Operation Manual” before use.