

testo 6351 · differential pressure transmitter

P2A software · Parameterizing, adjusting and analyzing software

Instruction manual

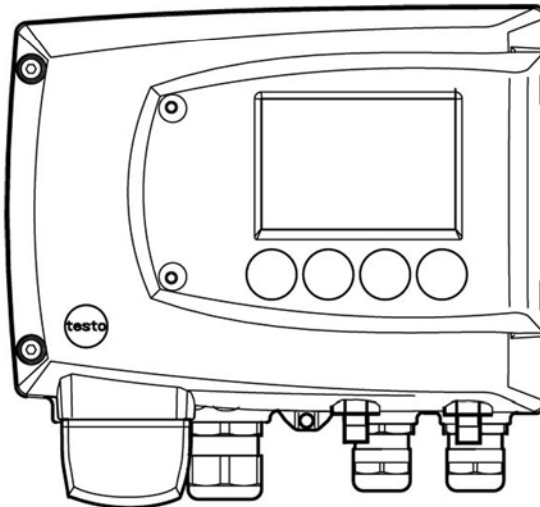

1 Safety and the environment

Avoiding electrical hazards

- > Never use the instrument and connected probes to measure on or near live parts!
- > Damaged mains cables must only be replaced by authorized personnel.
- > Only have the transmitter wired and connected by authorized personnel with the voltage disconnected.
- > You must always comply with the regulations applicable in your country for opening and repairing electrical equipment.

Avoiding personal injury and damage to equipment

- > Installation, setting and calibration work must only be carried out by qualified and authorized personnel!
- > Only open the instrument when this is expressly described in the instruction manual for installation, maintenance or repair purposes.
- > Observe the permissible storage, transport and operating temperature.
- > Do not store the product together with solvents. Do not use any desiccants.
- > Do not use the instrument for control purposes at the same time as operating or servicing the transmitter.
- > Only operate the product properly, for its intended purpose and within the parameters specified in the technical data. Do not use any force.
- > Carry out only the maintenance and repair work on this instrument that is described in the documentation. Follow the prescribed steps exactly. Use only original spare parts from Testo.

Any additional work must only be carried out by authorized personnel. Otherwise testo will not accept any responsibility for the proper functioning of the instrument after repair and for the validity of certifications.



Protecting the environment

- > At the end of its useful life, send the product to the separate collection for electric and electronic devices (observe local regulations) or return the product to Testo for disposal.

2 About this document

Use

- > Please read this documentation through carefully and familiarize yourself with the product before putting it to use. Pay particular attention to the safety instructions and warning advice in order to prevent injuries and damage to the products.
- > Keep this document to hand so that you can refer to it when necessary.
- > Hand this documentation on to any subsequent users of the product.

 WARNING	Indicates potential serious injuries
 CAUTION	indicates potential minor injuries

Symbols and writing standards

Representa- tion	Explanation
i	Note: Basic or further information.
1. ...	Action: more steps, the sequence must be followed.
2. ...	
> ...	Action: a step or an optional step.
- ...	Result of an action.
Menu	Elements of the program interface.
[OK]	Buttons of the program interface.
... ...	Functions/paths within a menu.
“...”	Example entries

3 Contents

1	Safety and the environment	3
2	About this document	4
3	Contents	5
4	Transmitter	8
4.1.	Specifications.....	8
4.1.1.	Functions and use.....	8
4.1.2.	Scope of delivery.....	8
4.1.3.	Accessories.....	8
4.1.4.	Technical data.....	9
4.1.5.	Dimensions.....	12
4.2.	Product description.....	13
4.2.1.	At a glance.....	13
4.2.2.	Display and keypad.....	14
4.2.3.	Service interface.....	15
4.2.4.	Relay board (option).....	15
4.2.5.	Analog outputs.....	15
4.2.6.	Parameters.....	15
4.2.7.	Scaling.....	16
4.2.8.	Alarm handling.....	17
4.3.	Commissioning.....	18
4.3.1.	Assembling the instrument.....	18
4.3.1.1.	Wall mounting.....	18
4.3.2.	Connecting the instrument.....	19
4.3.2.1.	Overview of terminals.....	21
4.3.2.2.	Connecting voltage supply and analog outputs.....	22
4.3.2.3.	Connecting the relay outputs.....	23
4.3.2.4.	Plug-in connection option.....	26
4.3.2.5.	Closing the instrument.....	27
4.3.3.	Adjusting the instrument.....	29
4.3.3.1.	Analog output adjustment.....	29
4.3.3.2.	n-point adjustment.....	30
4.4.	Operation.....	31
4.4.1.	Relationship between user menu and mini-DIN socket is active.....	31
4.4.2.	Key cover.....	31
4.4.3.	Password protection.....	32
4.4.4.	Structure of user menu.....	32
4.4.5.	Overview of the testo 6351 user menu.....	34
4.4.6.	The individual main menus.....	37
4.4.6.1.	Editing main menu of channel 1.....	37
4.4.6.2.	Editing Main Menu Alarm.....	37
4.4.6.3.	Editing Main Menu Settings.....	39

4.4.6.4. Editing Main Menu Analysis	42
4.4.6.5. Editing Message main menu	44
4.4.6.6. Calling up Main Menu Ident	45
4.4.6.7. Editing Main Menu Adjust	45
4.4.6.8. Editing Reset main menu	47
4.5. Status, warning and error messages	47
4.5.1. Status messages	48
4.5.2. Warning messages	49
4.5.3. Transmitter error messages	50
4.5.4. Handling alarm messages	50
4.5.5. Namur fault conditions	51
4.6. Maintenance and cleaning	52
4.6.1. Maintaining the instrument	52
4.6.2. Cleaning the instrument	52
5 Parameterizing, adjusting and analyzing software (P2A software) ..	53
5.1. Specifications	53
5.1.1. Functions and use	53
5.1.2. System requirements	54
5.1.3. Scope of delivery	54
5.2. First steps	55
5.2.1. Installing the software/driver	55
5.2.1.1. Installing P2A software	55
5.2.1.2. Installing USB driver	55
5.2.1.3. P2A software upgrade	55
5.2.2. Starting the software	55
5.2.2.1. Starting the program	55
5.2.2.2. Establishing a connection with the instrument	55
5.2.2.3. Activating the connection with the instrument	56
5.3. Using the software	56
5.3.1. User interface	56
5.3.2. Editing instrument/parameter file	59
5.3.2.1. Changing instrument/parameter file	59
5.3.2.2. Saving parameters	66
5.3.2.3. Opening the parameter file	67
5.3.2.4. Copying and pasting parameters	67
5.3.2.5. Deleting instrument/parameter file	68
5.3.2.6. Creating a new instrument file	68
5.3.3. Analyzing/testing the transmitter	68
5.3.3.1. Analyzing/testing the instrument	68
5.3.3.2. Carrying out factory reset	69
5.3.3.3. Testing analog output	69
5.3.3.4. Testing switch output relays 1 to 4	71
5.3.3.5. Displaying min./max. values	72
5.3.4. Adjusting the transmitter	73
5.3.4.1. n-point adjustment	73
5.3.4.2. Adjusting the analog output	74

5.3.5. Transmitter history	75
6 Tips and assistance.....	79
6.1. Questions and answers	79
6.2. Accessories and spare parts	79
6.2.1. Ordering options for testo 6351 transmitter (0555 6351)	80

4 Transmitter

4.1. Specifications

4.1.1. Functions and use

The testo 6351 transmitter is suitable for the following applications, amongst others:

- Test benches
- Clean rooms
- Filling processes
- Complex room climate applications
- Monitoring flow velocities or volumetric flow rates in air conditioning systems

4.1.2. Scope of delivery

The scope of delivery of the testo 6351 transmitter includes the following:

- Key cover
- Rear panel bracket
- Instruction manual
- Calibration report
- CD-ROM with operating instructions (PDF), configuration files for Ethernet module and P2A update (this can only be used in conjunction with the P2A software, which has to be ordered separately).

4.1.3. Accessories

The following accessories are available for the testo 6351 transmitter, amongst others:

- Mains unit
- P2A software (parameterizing, adjusting and analyzing software)
- Assembly accessories



Information about accessories and their order numbers can be found in **Accessories and spare parts** or on the website at www.testo.com.

4.1.4. Technical data

Parameter

- Differential pressure

Accuracy



The specifications are only valid if the positive pressure is applied at the positive pressure connection.

- ± 0.8 % of measuring range final value, additional ± 0.3 Pa intrinsic error¹
- $T_{K \text{ slope drift}} = 0.03$ % of measuring range per degree Kelvin of deviation from nominal temperature 22 °C
- $T_{K \text{ zeroing drift}} = 0$ %, as zeroing with solenoid valve²

Measuring range, resolution and overload

Measuring range depending on resolution ordered	Resolution	Overload
0 to 50 Pa	0.1 Pa	20,000 Pa
0 to 100 Pa	0.1 Pa	20,000 Pa
0 to 500 Pa	0.1 Pa	20,000 Pa
0 to 10 hPa	0.01 hPa	200 hPa
0 to 50 hPa	0.01 hPa	750 hPa
0 to 100 hPa	0.1 hPa	750 hPa

¹ Measuring uncertainty in accordance with GUM: ± 0.8 % of measuring range final value ± 0.3 Pa.

GUM (Guide to the Expression of Uncertainty in Measurement): ISO guideline for determining the measuring uncertainty in order to render global measurement results comparable.

The following uncertainties are used during the inquiry:

- Hysteresis
- Linearity
- Reproducibility
- Adjustment area/factory calibration
- Test location

² Minor mixtures of the media may occur at the positive and negative pressure side due to the automatic zeroing cycle.

Measuring range depending on resolution ordered	Resolution	Overload
0 to 500 hPa	0.1 hPa	2500 hPa
0 to 1000 hPa	1 hPa	2500 hPa
0 to 2000 hPa	1 hPa	2500 hPa
-50 to 50 Pa	0.1 Pa	20,000 Pa
-100 to 100 Pa	0.1 Pa	20,000 Pa
-500 to 500 Pa	0.1 Pa	20,000 Pa
-10 to 10 hPa	0.01 hPa	200 hPa
-50 to 50 hPa	0.01 hPa	750 hPa
-100 to 100 hPa	0.1 hPa	750 hPa
-500 to 500 hPa	0.1 hPa	2500 hPa
-1000 to 1000 hPa	1 hPa	2500 hPa
-2000 to 2000 hPa	1 hPa	2500 hPa



Upon delivery and following a factory reset the readings are shown in the display in the unit that was ordered via the KMAT option Fxx, see Ordering options for testo 6351 transmitter (0555 6351), page 80.

Meas. cycle

- 1/sec

Interface

- Mini-DIN for P2A software (adjustment and parameterization software)
- optional: Ethernet module

Voltage supply

- 4-wire (separate signal and supply lines): 20 to 30 V AC/DC, 300 mA power consumption

Maximum load

- 4-wire: 500 Ω (power output)

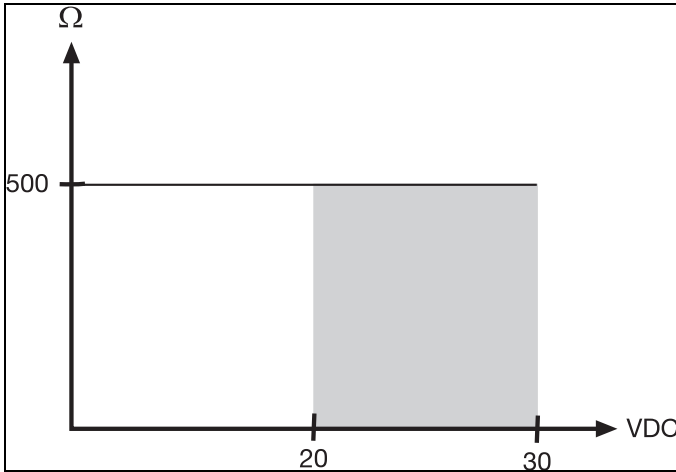

Maximal load

- 4-wire: 10 k Ω (voltage output)

Analog output

- 0 to 1 V \pm 1.5 mV (4-wire) or
- 0 to 5 V \pm 7.5 mV (4-wire) or
- 0 to 10 V \pm 15 mV (4-wire) or
- 0 to 20 mA \pm 0.03 mA (4-wire) or
- 4 to 20 mA \pm 0.03 mA (4-wire)
- $T_K = 0.05$ %K of measuring range per degree Kelvin of deviation from nominal temperature 22 $^{\circ}$ C

Resolution of analog output

- 12 bit

Relay

- 4 relays, 250 V AC/DC, 3 A (optional)

Display

- 2-line LCD with plain text line (optional)

Operating temperature

- -5 to 50 $^{\circ}$ C/23 to 122 $^{\circ}$ F

Storage temperature

- -20 to 60 °C/-4 to 140 °F

Process temperature

- -20 to 65 °C/-4 to 149 °F

Housing, weight

- Plastic, 0.7 kg
- Optional Ethernet intermediate layer: 0.6 kg

Protection class

- IP 65 only if the transmitter is wired and/or sealing plugs are inserted

Directives, standards and tests

- EC Directive: 2004/108/EC

Warranty

- Duration: 2 years
- Warranty conditions: see website www.testo.com/warranty

4.1.5. Dimensions

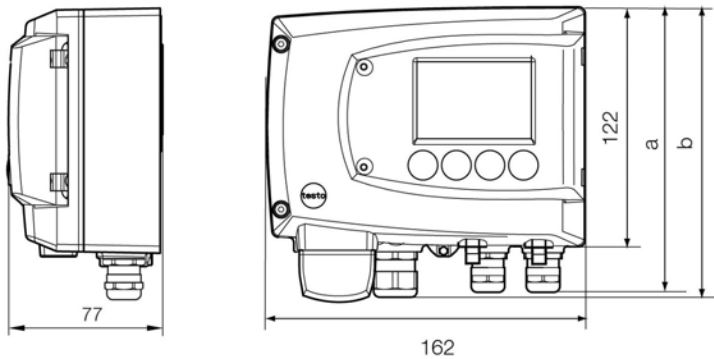

Dimensions in mm	a	b
with M20 cable couplings	144	147
With NPT cable coupling	144	144
With M plug-in connection	143	

4.2. Product description

4.2.1. At a glance

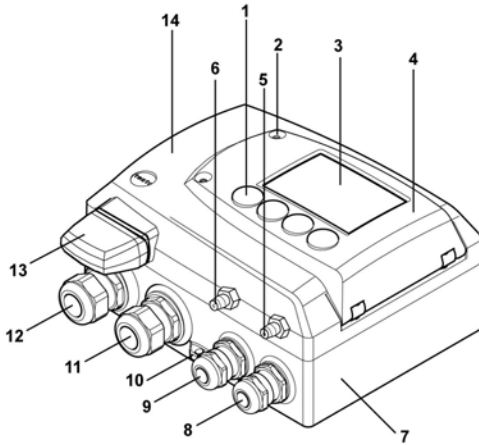

- 1 Keys (only with optional display)
 - 2 Service flap screw connection (self-locking, 2 pcs.)
 - 3 Display (optional)
 - 4 Service flap
 - 5 Negative pressure connection
 - 6 Positive pressure connection, marked with a red washer
 - 7 Lower part of housing
 - 8 M 16 x 1.5 screw connection*, e.g. analog outputs
 - 9 M 16 x 1.5 screw connection*, e.g. voltage supply
 - 10 Eyelet for measuring point panel
 - 11 M 20 x 1.5 screw connection*, e.g. R3 and R4 relays
 - 12 M 20 x 1.5 screw connection*, e.g. R1 and R2 relays
 - 13 Adjusted probe plug (non-functional probe socket)
 - 14 Upper part of housing
- * Alternatively, NPT cable couplings or M plug-in connections are available

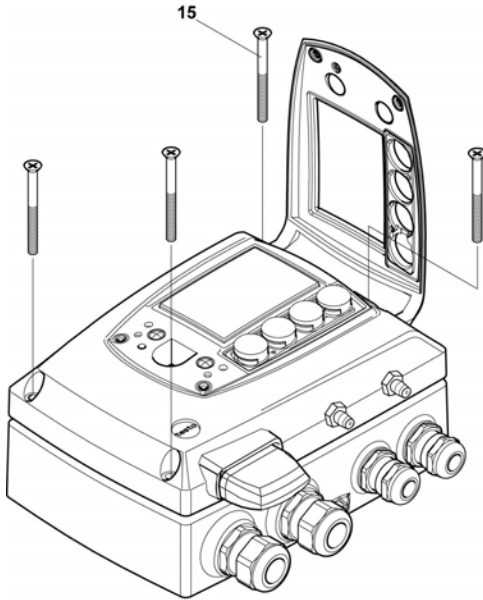

15 Housing screws

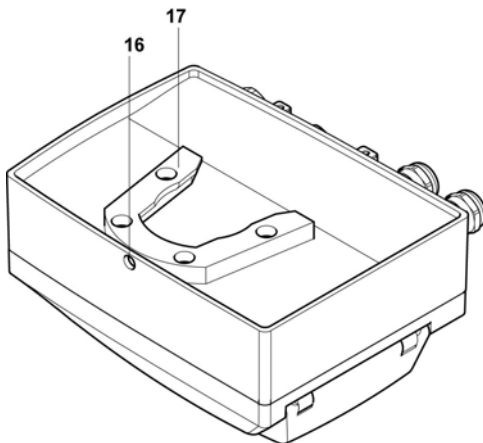

16 Hole for fastening to rear panel bracket (M3 x 6 screw)

17 Plastic bracket for assembly on rear panel

4.2.2. Display and keypad

The display option allows operation of the testo 6351 transmitter via the display and four keys.

The LCD display consists of two 7-segment lines for displaying readings and units and of an information line (for status messages, for example).

The brightness and contrast of the display and the background lighting (permanent or off) can be changed via the user menu or the P2A software.

4.2.3. Service interface

The parameterizing socket (mini-DIN) is located behind the service flap as an interface to the P2A software.

4.2.4. Relay board (option)

This has a floating switch capacity of 250 V AC/3 A. The switching limits and hysteresis as well as the function as relay for the collective alarm can be set via the display or the P2A software.

Further features include:

- Function of changeover contacts (NC/NO contacts) freely selectable
- 12 terminals for a total of 4 relays.



If no relays are available, settings for monitoring limit values or alarms can still be controlled via the display. The alarm status will be shown on the display.



Only have the transmitter wired and connected by authorized personnel with the voltage disconnected.

4.2.5. Analog outputs

As analog outputs, the testo 6351 has either

- 1 current output of 0 to 20 mA (4-wire)/4 to 20 mA (4-wire) or
- 1 voltage output of 0 to 1 V/0 to 5 V/0 to 10 V (4-wire)

4.2.6. Parameters

The following parameters are displayed:

- Differential pressure in Pa, hPa, kPa, mbar, bar, mmH₂O, inch H₂O, inch HG, kg/cm², PSI
- Flow³ in m/s, ft/min

³ To prevent fluctuating flow rate values at the zero point (depressurized), the flow rate values are only calculated as of differential pressures > 0.2 Pa or

- Volumetric flow rate⁴ in m³/h, l/min, Nm³/h, NI/min

4.2.7. Scaling

There are three types of min./max. values:

- 1 The measuring range: The maximum sensor performance is in this range. Values outside of the measuring range are displayed via messages, for example. Measuring range, see table (below).
- 2 Standard scaling: The output signals are assigned to this measuring range as standard:
 - during delivery if no entries are made in the order code
 - after exchanging the unit, the measuring range recorded in the instrument is applied as standard.



The transmitter even retains its scaling with the voltage disconnected.

Measuring range, see table (below).

- 3 The maximum settings for the manual scaling
 - The maximum limits can be calculated as follows:
 $X = \text{difference between MIN. and MAX. value of the standard scaling}$
 $(\text{Max. value of standard}) + (50 \% \text{ of } X)$
 $(\text{Min. value of standard}) - (50 \% \text{ of } X)$
 - It is thus possible to scale beyond the measuring range, e.g. for the adjustment of the scaling limits to standard values of a PLC.

With the alarm definition, however, the physical measuring range limits are decisive.

Measuring range/standard scaling	Maximum scaling
0 to 50 Pa	-25 to 75 Pa
0 to 100 Pa	-50 to 150 Pa
0 to 500 Pa	-250 to 750 Pa
0 to 10 hPa	-5 to 15 hPa

> 0.1 % of the respective measuring range (whichever is the greater). With smaller differential pressures, the flow rate value remains at 0.00 m/s.

⁴ Calculated

Measuring range/standard scaling	Maximum scaling
0 to 50 hPa	-25 to 75 hPa
0 to 100 hPa	-50 to 150 hPa
0 to 500 hPa	-250 to 750 hPa
0 to 1000 hPa	-500 to 1500 hPa
0 to 2000 hPa	-1000 to 3000 hPa
-50 to 50 Pa	-100 to 100 Pa
-100 to 100 Pa	-200 to 200 Pa
-500 to 500 Pa	-1000...1000
-10 to 10 hPa	-20 to 20 hPa
-50 to 50 hPa	-100 to 100 hPa
-100 to 100 hPa	-200 to 200 hPa
-500 to 500 hPa	-1000 to 1000 hPa
-1000 to 1000 hPa	-2000 to 2000 hPa
-2000 to 2000 hPa	-4000 to 4000 hPa

4.2.8. Alarm handling

For upper and lower alarm limits, individual alarms as well as collective alarms can be specified. If the collective alarm function is activated, an alarm is triggered as soon as the alarm limit of an alarm is exceeded, if this alarm is assigned to the collective alarm.

The testo 6351 monitors limit values with the help of relays. If a reading is outside the limit values, a relay to be specified by the user is switched.

If the reading reverts to more than a specified hysteresis below or above the limit value, the alarm is cancelled.

In addition, information about the occurrence of error/status messages can be provided by means of a collective alarm relay, see Status, warning and error messages, page 47



If multiple alarm messages are activated at the same time, the last alarm is shown. If the alarm is cancelled again, the previous messages are no longer shown.

4.3. Commissioning

4.3.1. Assembling the instrument

4.3.1.1. Wall mounting

Attaching rear panel bracket

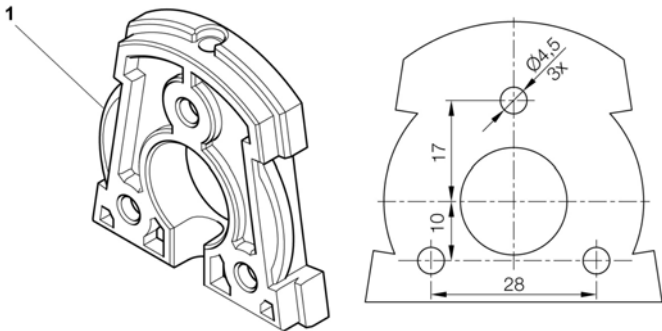

1. Remove locking screw (see item (4) of drawing below) and detach rear panel screw from plastic bracket (see item (2) of drawing below).
2. Hold rear panel bracket in assembly position and mark the three drill holes.
3. Drill three holes (\varnothing 5 mm) and insert dowels where necessary.
4. Screw on rear panel bracket.

Remember that the clamping brackets (1) must face the wall.

Fastening instrument to rear panel bracket

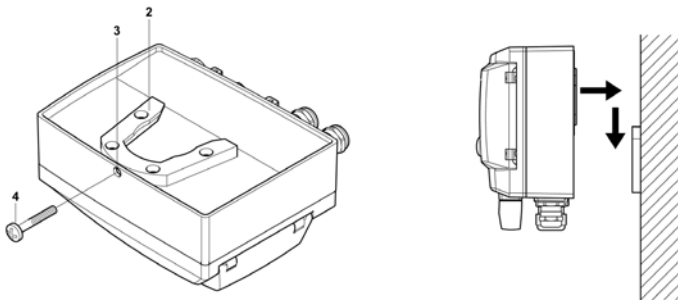

1. Slide plastic bracket (2) on the back of instrument onto rear panel bracket until it engages (see arrows).
2. Insert screw (4) through hole (3) and screw into rear panel bracket.

4.3.2. Connecting the instrument

Opening the instrument

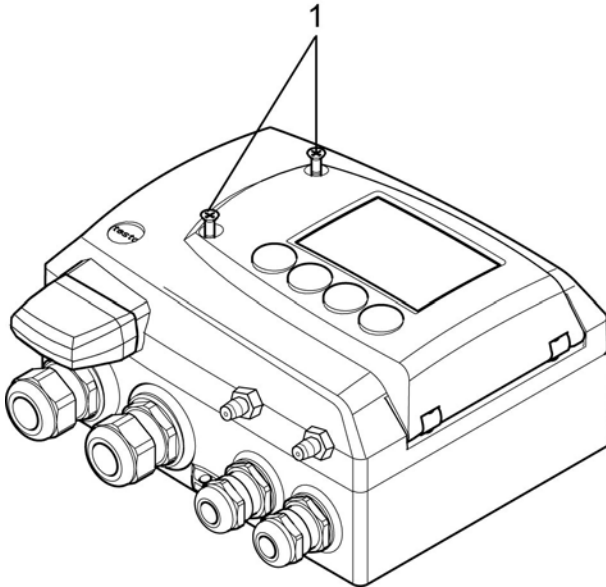

1. Loosen screw connection (1) of service flap and open the flap.

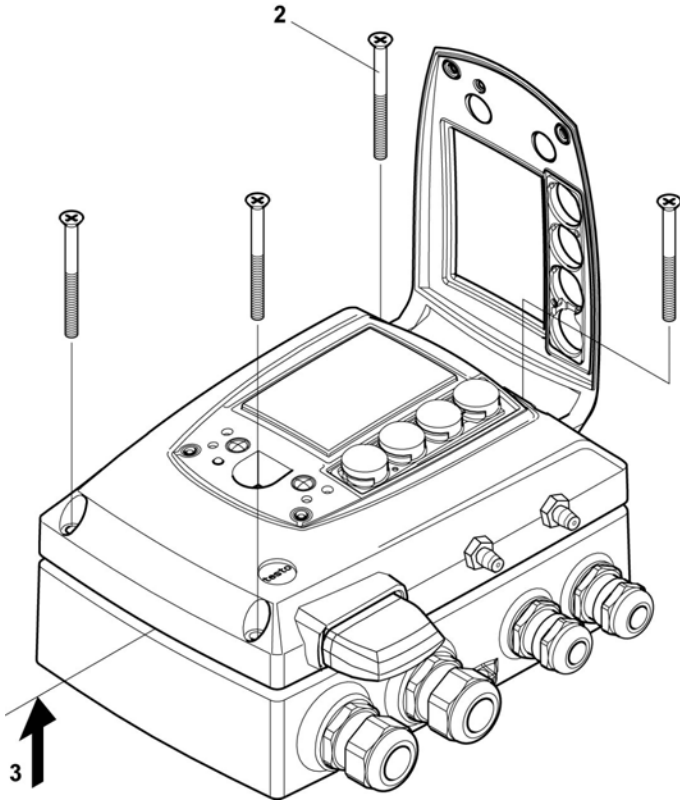

2. Loosen and remove housing screws (2).
3. Remove upper part of housing from lower part (3) and place on a clean surface.

⚠ WARNING

Electrical voltage

Danger of injury!

- > De-energize the mains connection before connecting the transmitter.



Only have the transmitter wired and connected by authorized personnel with the voltage disconnected.

4.3.2.1. Overview of terminals

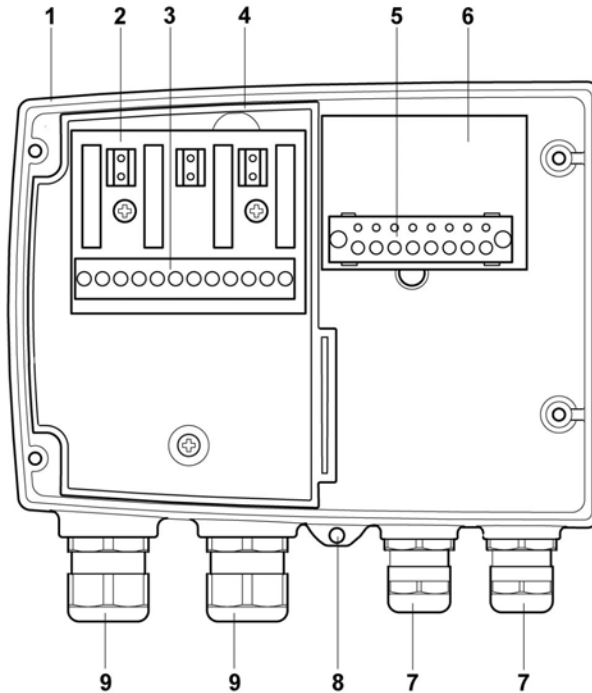

- | | | | |
|---|--|---|---|
| 1 | Lower part of housing | 6 | Terminal board |
| 2 | Relay board (option) | 7 | M 16 x 1.5 screw connection* |
| 3 | Relay terminals | 8 | Eyelet for measuring point panel |
| 4 | Insulating trough for relay board | 9 | M 20 x 1.5 screw connection* |
| 5 | Terminal strip for voltage supply and analog outputs | | * Alternatively, NPT cable coupling or M plug-in connection |



The following description of the terminals refer to this overview and its numbering.

4.3.2.2. Connecting voltage supply and analog outputs

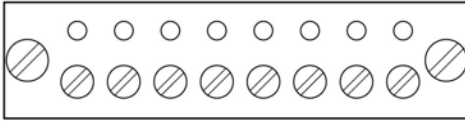

Terminal strip for voltage supply and analog outputs, item (5) of overview of terminals, page 21

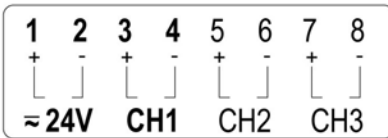

i Channels 2 and 3 shown on the circuit board cannot be used with this instrument.

1. Disconnect connector.
2. Strip the cable ends, clamp wire end ferrules on and screw down onto voltage terminals.
3. Insert connector into socket.

Wiring diagram for 4-wire system (0 to 20 mA/4 to 20 mA/0 to 1 V/0 to 5 V/0 to 10 V)

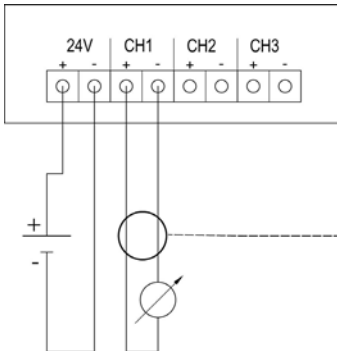

1-channel
 0 to 20 mA/4 to 20 mA
 max. load per 500 Ω
 0 to 1 V/0 to 5 V/0 to 10 V

i Channels 2 and 3 shown on the circuit board cannot be used with this instrument.

- i** Requirement for the connecting cable of the supply:
- Insulated with cross-section of at least 0.25 mm², maximum 2.7 mm² without wire end sleeves.
 - The supply line must be secured against exceeding 8 A.
 - An OFF switch must be installed in an easily accessible position close by and be marked as such.

1. Disconnect connector.
2. Strip the cable ends, clamp wire end ferrules on and screw to channel terminals as shown in diagram.
3. Insert connector into socket.

4.3.2.3. Connecting the relay outputs



Only have the transmitter wired and connected by authorized personnel with the voltage disconnected.

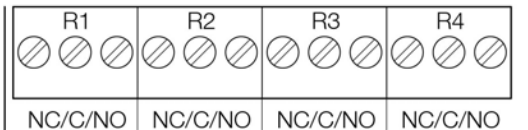

Relay terminal strip, item (3) of overview of terminals

There is the option of twelve terminals for a total of four relays. The designations NC/C/NO (normally closed contact/root or pin/normally open contact) are etched on the surface of the board.

Using PG screw connection

1. Feed connection cables for the relays through opened M 20 x 1.5 screw connection (item (10) of overview of terminals).
2. Strip cable ends and clamp on wire end ferrules.
3. Connect relays according to chosen function (NC/NO) (see diagrams below; relay 1 is shown as an example of a connection).

Using plug-in connections (optional)



Only insert or disconnect the plug-in connection when the voltage is disconnected.

4. Clean the connector of the probe line and the coupling of any foreign matter.



Do not disconnect the connector of the probe line from the instrument for extended periods to protect against contamination.

Use of relay as NC contact (NC = normally closed)

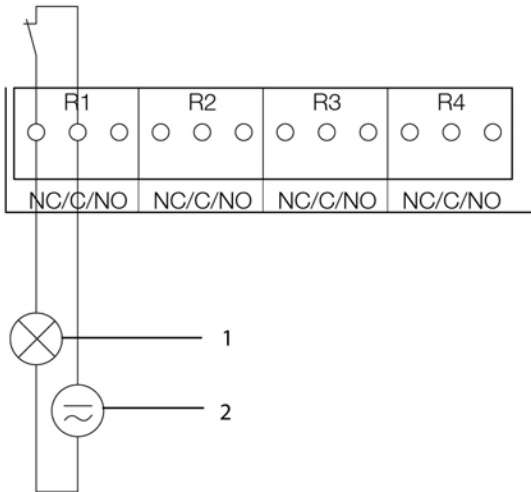

- 1 Alarm/status light
(example of installation)
- 2 250 V AC/DC, 3 A



The busy light (alarm/status light) is permanently on until the relay opens or the circuit is interrupted. This circuit can therefore be used to monitor the functionality of the alarm circuit, as a cable break, for instance, is indicated by the busy light going off.

Use of relay as NO contact (NO = normally open)

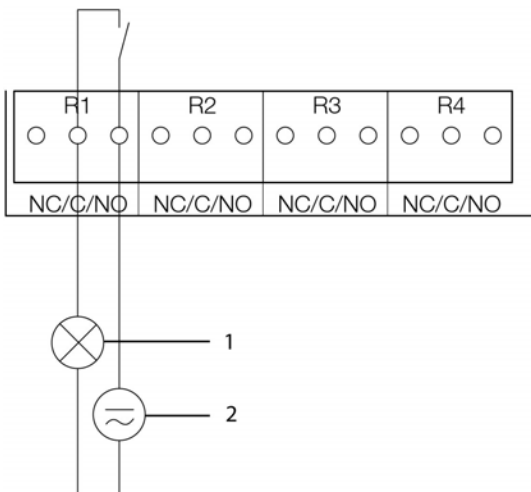

- 1 Alarm/status light
(example of installation)
- 2 250 V AC/DC, 3 A

i The busy light (alarm/status light) only comes on when the relay is switched (closed). Monitoring the functionality of the alarm circuit is therefore not possible with this switching operation.

- Close M 20 x 1.5 screw connection (item (9) in overview of terminals).

4.3.2.4. Plug-in connection option

As an option, the PG screw connections of the signal and supply lines can be replaced with plug-in connections that are installed at the housing, see item 1 and 2. The relay cabling occurs via standard cable entries and PG screw connections.

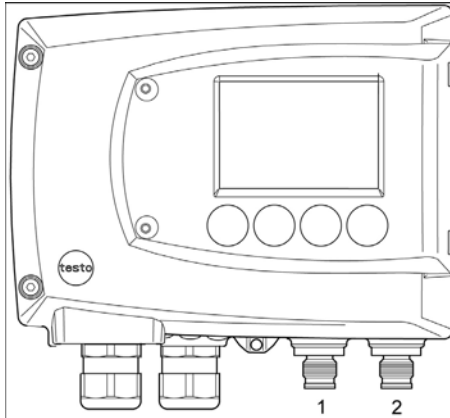

Plug-in connections for power supply and channels

M12 plug-in connection (5-pin) socket (item 1)

View of the plug-in connections in the installed state from outside

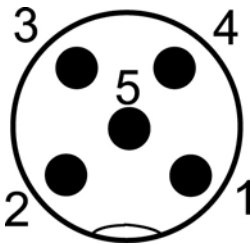

PIN	Assignment
1	V 24-
2	V 24+
3	+ Ch1
4	- Ch1
5	PE

4.3.2.5. Closing the instrument

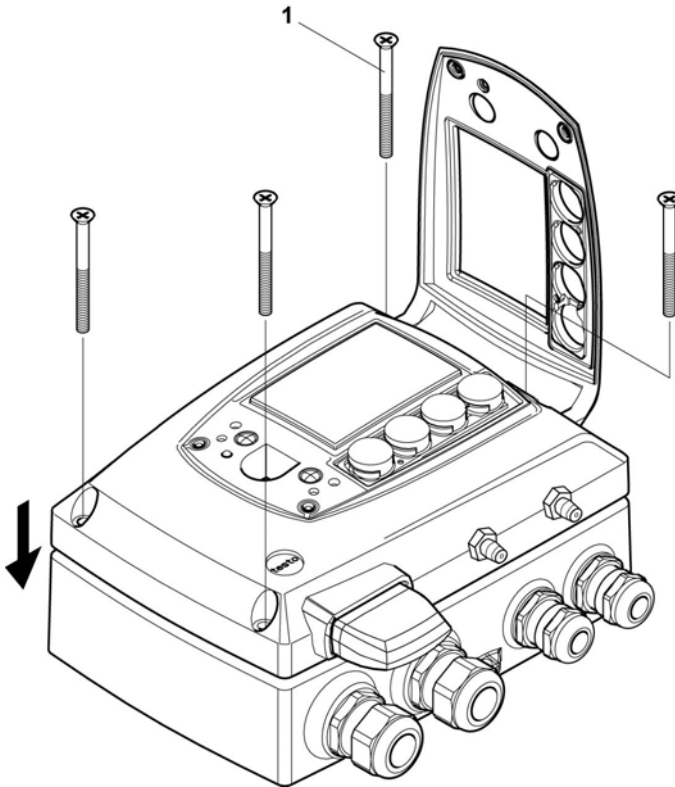

1. Place upper part of instrument on top of lower part (see arrow) and fix in place with housing screws (1).

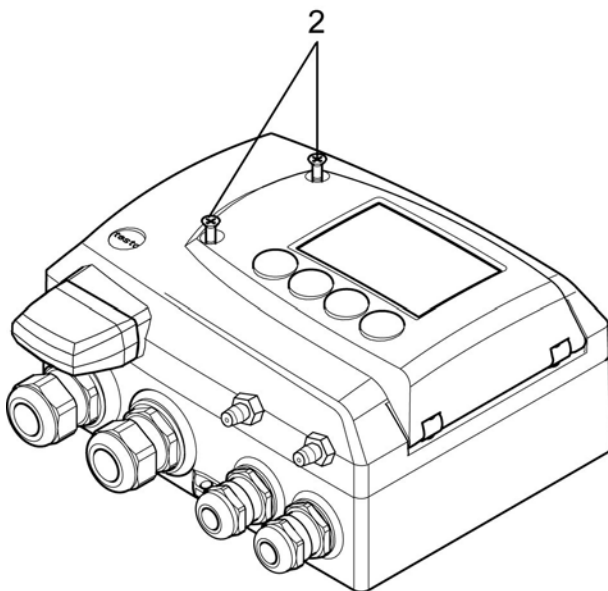

2. Close the service flap and tighten screws (2).

4.3.3. Adjusting the instrument

4.3.3.1. Analog output adjustment

The purpose of adjusting the analog outputs is to adjust the signal chain from the digital signal (within the transmitter) to the analog outputs. The signal type that was appointed for the transmitter is adjusted respectively for each channel (e.g. 4 to 20 mA or 0 to 1 V, etc.).

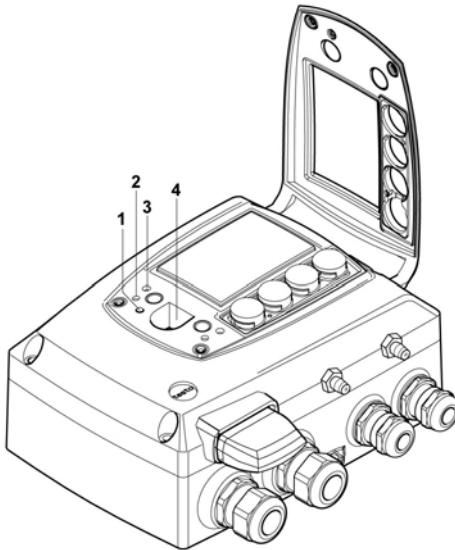

- 1 Status LED
- 2. Contact ch. 1+
- 3. Contact ch. 1-
- 4. Service interface

Adjusting analog output 1

- ✓ With testo 6351 with current output: Load of max. 500Ω is connected to channel 1 (see Plug-in connections for power supply and channels, page 26)
- ✓ A precise multimeter (minimum requirement: resolution 6.5 digits, at least 5-times more accurate than the 6351) is available.



If only a simple multimeter is available, the analog output must not be adjusted.

- ✓ The service flap is open.
- 1. Connect the inputs of the multimeter with the contacts (2) and (3) for channel 1.

2. Transfer the reference analog value measured with the multimeter into the P2A software (see Adjusting the analog output, page 74) or enter it via the user menu (see Performing analog adjustment, page 45).
3. Disconnect connections between the multimeter and the contacts of the testo 6351 and close the service flap.

4.3.3.2. n-point adjustment

With an n-point adjustment, the parameters at the 3-6 measurement points are adjusted to the reference value. The reference conditions are obtained by using a precise pressure sensor that should be 5-times more accurate than the transmitter.

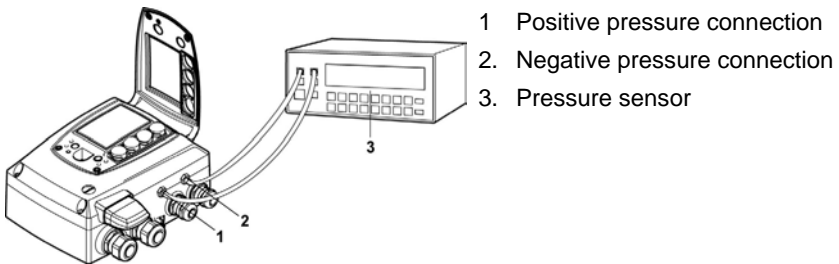

i The number of measuring points is set to 3 by the factory and can only be changed using the P2A software (see **n-point adjustment**, page 73).

i The n-point adjustment must always be carried out to its full extent and in good time at all selected measurement points.

- ✓ A precise pressure sensor (5-times more accurate than the transmitter, e.g. DPC precision pressure sensor from testo industrial services) is available.
1. Connect the positive output of the pressure sensor (3) to the positive pressure connection of the transmitter (1) and the negative output of the pressure sensor (3) to the negative pressure connection of the transmitter (2).
 2. Transfer the reference pressure value created with the pressure sensor into the P2A software (see n-point adjustment, page 73) or enter it via the user menu (see Performing analog adjustment, page 45).
 3. Repeat step 2 for all of the measuring points.
 4. Disconnect connections between the pressure sensor and the pressure connections of the testo 6351.

4.4. Operation

4.4.1. Relationship between user menu and mini-DIN socket is active

The testo 6351 can be parameterized using either the user menu or the P2A software (see Parameterizing, adjusting and analyzing software (P2A software) page 53).



The testo 6351 transmitter can only be operated via the display and keypad if the display option is available.

If the testo 6351 is connected to the P2A software, the user menu is blocked for the duration of the communication. The message Service plug is shown in the display of the testo 6351. As soon as the P2A software is disconnected, the user menu is accessible again.

4.4.2. Key cover

To prevent unauthorized operation of the keys, the standard key frame can be replaced with a key cover.

If the key cover has been assembled, the service flap must be opened for operation.

Attaching the key cover

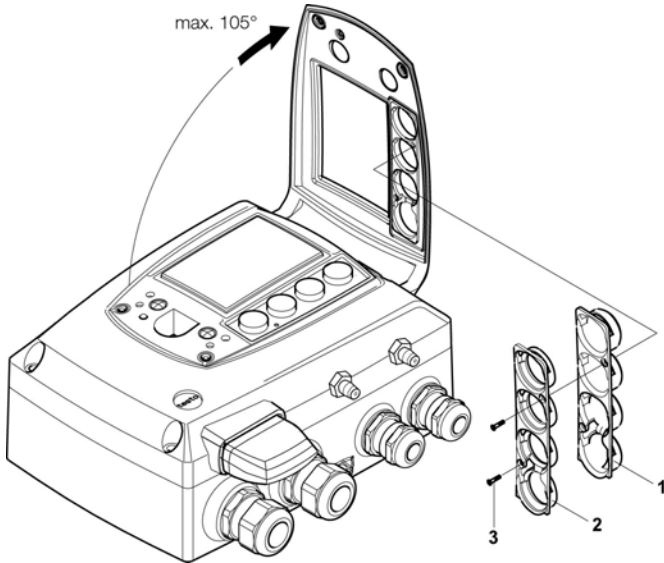

✓ The service flap is opened, see Opening the instrument, page 19.

1. Unscrew screws **(3)** and remove key frame **(2)**.
2. Insert key cover **(1)** into service flap and tighten screws **(3)**.
3. Close and screw down the service flap.

4.4.3. Password protection

The user menu can be protected with a four-digit numerical code (see Editing Main Menu Settings, page 39) so that access to the user menu is denied to unauthorized persons not familiar with this numerical code.

If the password protection is not to be used, the numerical code "0000" must be entered. This is also the status upon delivery.

4.4.4. Structure of user menu

At the main menu level, the user menu comprises the following:

- Main Menu Channel 1
- Main Menu Alarm
- Main Menu Settings

- Main Menu Analysis
- Main Menu Messages
- Main Menu Ident
- Main Menu Adjust
- Main Menu Reset

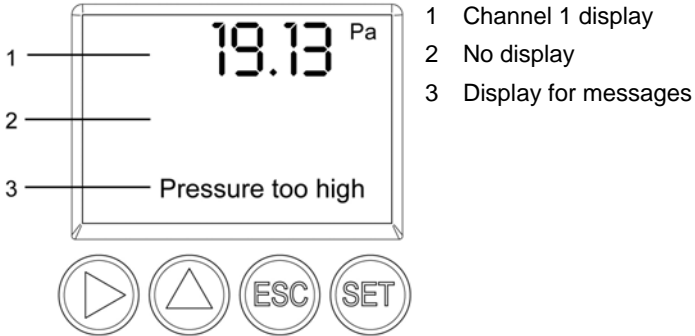

Four keys enable the user to navigate/scroll through the menus and enter/amend values and settings:

Key	Function/description
SET	<ul style="list-style-type: none"> • In Measuring Mode: changes to parameterization • In Parameterizing Mode: confirms a selection or setting
ESC	<ul style="list-style-type: none"> • Leaves a menu (without modifying any settings)
▶	<ul style="list-style-type: none"> • Selecting: scrolls through menus (downwards) or selectable alternatives • Editing: changes to next digit (to the right)
▲	<ul style="list-style-type: none"> • Selecting: scrolls through menus (upwards) or selectable alternatives • Editing: increases the value of the current digit by 1

4.4.5. Overview of the testo 6351 user menu

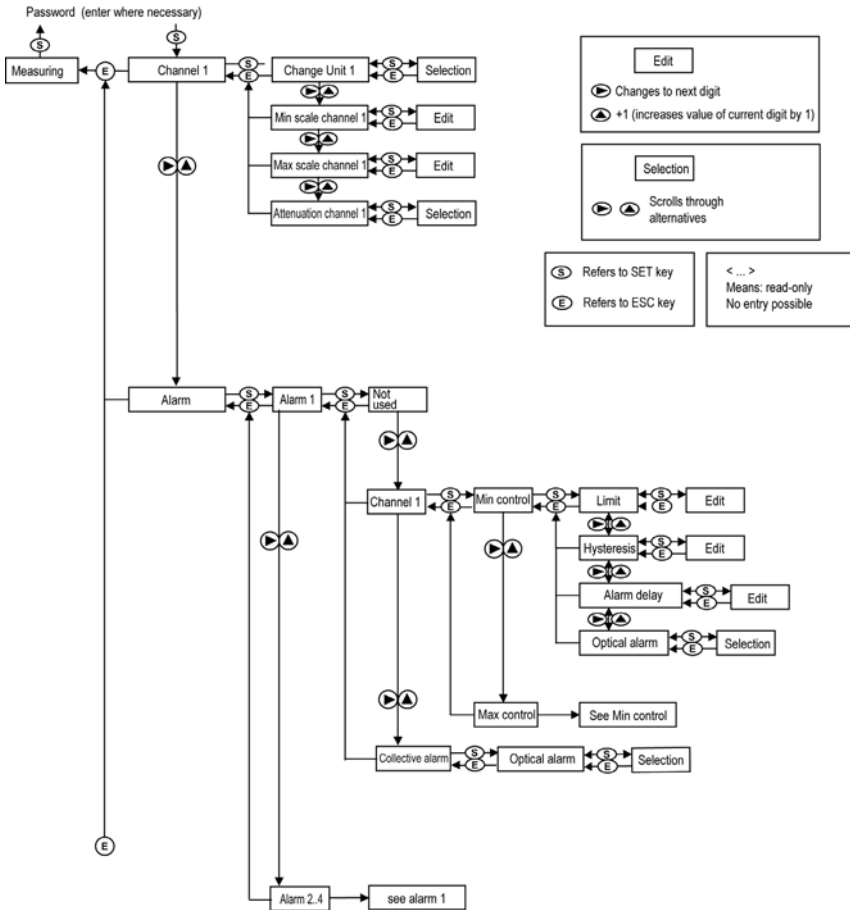

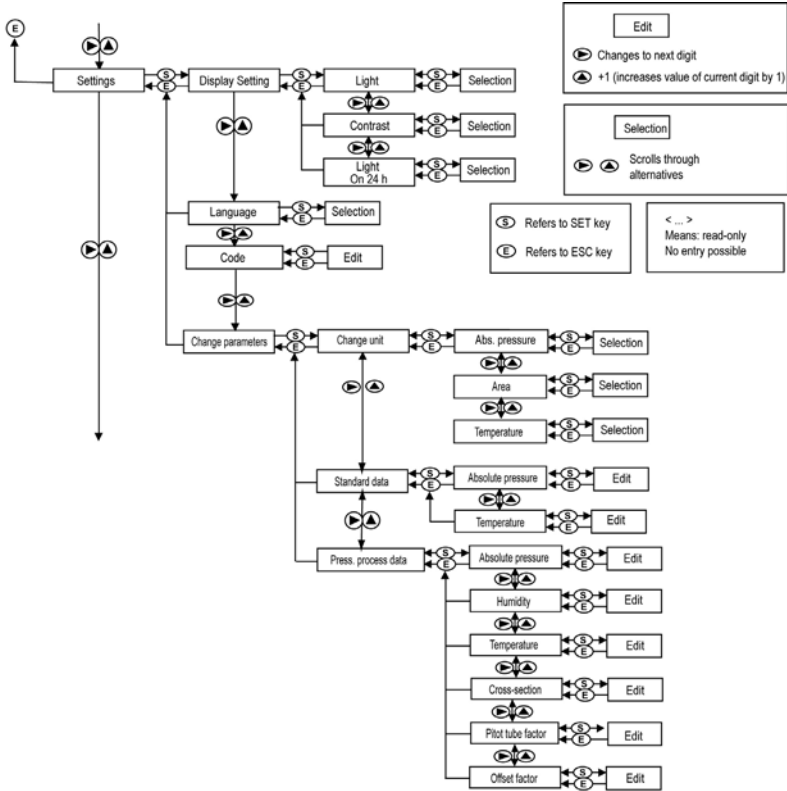

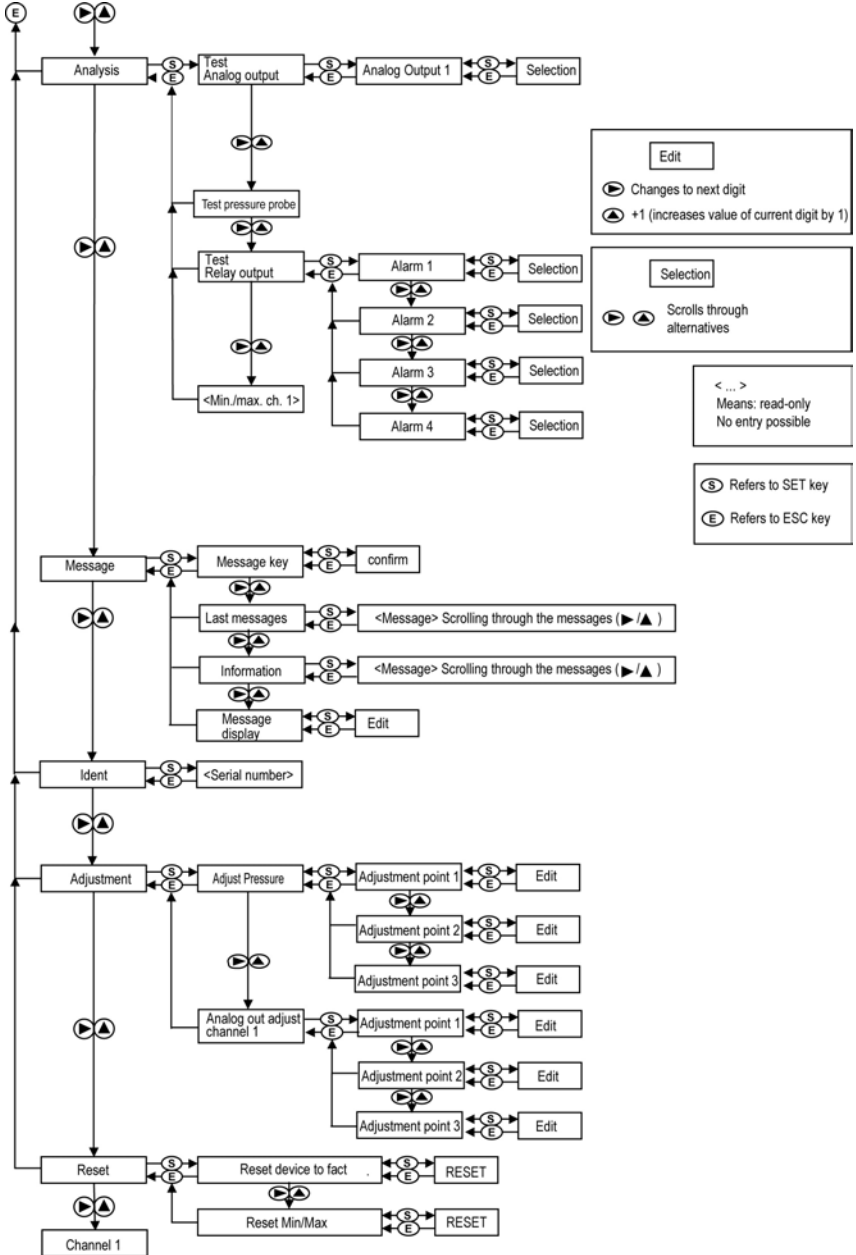

4.4.6. The individual main menus

4.4.6.1. Editing main menu of channel 1

An overview is given in Overview of the testo 6351 user menu, page 34).

You can perform basic settings for channel 1.

1. In the Measuring Mode press **SET**, select **Main Menu Channel 1** with **▶** or **▲** and confirm selection with **SET**.

One of the following parameters can now be selected using **▶** or **▲**, after which the selection must be confirmed with **SET**:

- Channel 1 Unit

The parameter for this channel is selected.

Edit/select parameter with **▶** or **▲**, confirm with **SET** or abort entry with **ESC**.

- Scale minimum for channel 1:

The lower scale limit is edited; Unit as selected above.

Editing the value: Scroll one digit to the right using **▶** and increase value of digit by 1 using **▲**. Confirm with **SET** or abort entry with **ESC**.

- Scale maximum for channel 1

The upper scale limit is edited;

Unit as selected above.

Editing the value: Scroll one digit to the right using **▶** and increase value of digit by 1 using **▲**. Confirm with **SET** or abort entry with **ESC**.

- Signal delay ("Attenuation") for channel 1

The analog signal can be delayed ("Attenuation"); a time constant is selected for this (1 = no delay; 15 = longest delay)

Edit/select parameter with **▶** or **▲**, confirm with **SET** or abort entry with **ESC**.

2. Continue to the main menu with **▶** or **▲** or return to Measuring Mode with **ESC**.

4.4.6.2. Editing Main Menu Alarm

With the alarm, the relays, available as options, are programmed. In addition, the alarm statuses are shown on the display (top right) (even without relays).

You can choose whether the alarm is to be used to monitor limit values or as a collective alarm. If an alarm is to be used to monitor limit values, you can choose between monitoring the minimum or maximum value and set a limit value and hysteresis for each alarm.

In addition, every alarm can be linked to a clearly visible visual alarm (display background lighting flashes).

An alarm delay between 0 and 240 seconds can still be assigned to every alarm used for limit value monitoring so that both the corresponding relay effect and the visual alarm are delayed. If the alarm status goes out within the set alarm delay time, neither the visual alarm nor a relay connection is triggered. .

With an alarm status present, the visual alarm and all relay outputs can be reset by means of acknowledgement. The triggering of a new alarm cannot be enabled until after the alarm status goes out.

1. In the Measuring Mode press **SET**, select **Main Menu Alarm** with **▶** or **▲** and confirm selection with **SET**.
 - Four alarms can be parameterized.
2. Select **Alarm x** with **▶** or **▲** and confirm selection with **SET**.

Using alarm to monitor limit values

NO contact

Monitoring minimum

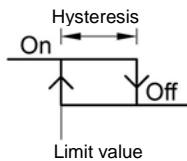

Monitoring maximum

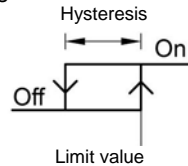

NC contact

Monitoring minimum

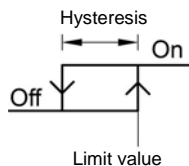

Monitoring maximum

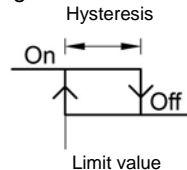

3. Select **Channel x** (e.g. "Channel 1") with **▶** or **▲** and confirm selection with **SET**.
4. Select **Max control** or **Min control** with **▶** or **▲** (see graphic).
5. Press **SET** and edit **Limit value** as well as **Hysteresis**: Scroll one digit to the right using **▶** and increase value of digit by 1 using **▲**. Confirm with **SET** or abort entry with **ESC**.

6. Select **Visual alarm** with ► or ▲. Select **YES** or **NO** with ► or ▲. Confirm with **SET** or abort entry with **ESC**.
7. Press **SET** and edit **Alarm delay**: Scroll one digit to the right using ► and increase value of digit by 1 using ▲ (0 to 240 seconds possible). Confirm with **SET** or abort entry with **ESC**.
8. Return to **Channel x** with **ESC**.
9. Return to **Alarm x** with **ESC**.
10. Change to the other relays using ► or ▲ and perform settings in the same way.

Using alarm as collective alarm or not using it at all

If an alarm is assigned to the collective alarm, the relay is switched and a visual alarm can be issued via the display as soon as (at least) one of the warning or error messages of the testo 6351 transmitter becomes active.



The messages affecting the collective alarm can only be selected in the P2A software, see Using the software, page 56

- ✓ Alarm is selected (see previous steps 1 and 2).
1. Use ► or ▲ to determine whether **Alarm x** should be used as a **Collective alarm** or **not used**. Confirm selection with **SET**.
 2. If collective alarm is selected: Select **Visual alarm** with ► or ▲. Select **YES** or **NO** with ► or ▲. Confirm with **SET** and return to **Alarm x**.
 3. Change to another alarm using ► or ▲ and perform settings in the same way.
 4. Return to **Main Menu Alarm** with **ESC**.
 5. Continue to **Main Menu Settings** with ► or ▲ or return to Measuring Mode with **ESC**.

4.4.6.3. Editing Main Menu Settings

You can edit instrument settings and other settings.

- > In Measuring Mode, press **SET**, select **Main Menu Settings** using ► or ▲ and confirm selection with **SET**.

You can edit settings for:

- Display
- Language
- Code
- Units

- Absolute pressure
- Area
- Temperature
- Standard data
- Process data

Editing display settings

You can set the brightness and contrast of the display.

1. Select **Display Settings** with ► or ▲ and confirm selection with **SET**.
2. Select **Backlight** or **Contrast** with ► or ▲ and confirm selection with **SET**.

One of the following parameters can now be selected using ► or ▲, after which the selection must be confirmed with **SET**:

- **Backlight**

The display illumination is changed.

Edit/select parameter with ► or ▲, confirm with **SET** or cancel entry with **ESC** (the effect of the change in parameter can be seen during input).

- **Contrast**

The brightness difference between the display background and the displayed values is changed.

Edit/select parameter with ► or ▲, confirm with **SET** or cancel entry with **ESC** (the effect of the change in parameter can be seen during input).

- **Backlight 24h on**

Select **On** or **Off** using ► or ▲ and confirm with **SET**.

Off: The display light switches off automatically if no button was pressed for 10 seconds.

On: The display light is activated

3. Return to **Display Settings** with **ESC** and use ► or ▲ to continue to **Language**.

Selecting language

You can select the language for the plain text line in the display.

- > Press **SET**, select required language with ► or ▲, confirm selection with **SET** and return to **Language**.



Only choose a language that you can understand well.

Select unit

This setting affects the unit of the standard and process data.

1. Press **SET**, select **Change parameters** with ► or ▲, confirm selection with **SET** or cancel with **ESC**.
2. Select **Change unit** with ► or ▲, confirm selection with **SET** or cancel with **ESC**.
3. Select the required variable (absolute pressure/area/temperature) with ► or ▲, confirm selection with **SET** or cancel with **ESC**.
4. Select the required unit with ► or ▲, confirm selection with **SET** or cancel with **ESC**.
5. Return to **Change unit** with **ESC** and continue to **Standard data** with ► or ▲.

Editing standard data

Setting individual values for the standard data to calculate the volumetric flow rate.

1. Select **Standard data** with ► or ▲, confirm selection with **SET** or cancel with **ESC**.
2. Select the required variable (absolute pressure/temperature) with ► or ▲, confirm selection with **SET** or cancel with **ESC**.
3. Scroll one digit to the right using ► and increase value of digit by 1 using ▲. Confirm with **SET** or abort entry with **ESC**.
4. Return to **Standard data** with **ESC** and use ► or ▲ to continue to **Pressure process data**.

Editing pressure process data

Setting of the process data for the Pitot tube calculation.

1. Select **Pressure process data** with ► or ▲ and confirm selection with **SET**.
2. Select the required variable (absolute pressure/humidity/temperature/cross-section/Pitot tube

factor/correction factor) with ► or ▲, confirm selection with **SET** or cancel with **ESC**.

3. Scroll one digit to the right using ► and increase value of digit by 1 using ▲. Confirm with **SET** or abort entry with **ESC**.
4. Return to **Pressure process data** with **ESC**.
5. Return to **Change parameters** with **ESC** and use ► or ▲ to continue to **Code**.

Editing code settings

You can set the access code (password).

i If a code other than "0000" (factory setting) is set, the transmitter can only be operated once this code has been entered via the menu.

1. Select **Code** with ► or ▲ and confirm selection with **SET**.
2. Scroll one digit to the right using ► and increase value of digit by 1 using ▲. Confirm with **SET** or abort entry with **ESC**.
3. Return to **Code** with **ESC**.
4. Return to **Main Menu Settings** with **ESC**.

4.4.6.4. Editing Main Menu Analysis

You can test the functionality of analog and relay outputs. In addition, you can read off the minimum and maximum values (since the last voltage supply or reset of the min./max. values).

Testing functionality of analog outputs

i This function affects the analog outputs directly, not only the test contacts.

1. In the Measuring Mode press **SET**, select **Main Menu Analysis** with ► or ▲ and confirm selection with **SET**.
 - **Test Analog Output** is shown.
2. Press **SET**, scroll one digit to the right using ► and increase value of digit by 1 using ▲. Any analog output value can be predefined, e.g. for an analog output of 4 to 20 mA, the value "6.0 mA". Confirm with **SET** or abort entry with **ESC**.
3. Accept setting by pressing **SET** and test with multimeter (minimum requirement: resolution 6.5 digits, at least 2-times more accurate than the 6351) as follows:

Analog output 1: Via test contacts under service flap, see diagram.

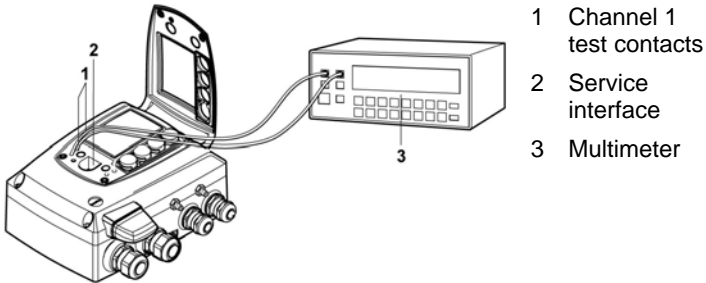

4. Return to **Test Analog Output** with **ESC** and use **▶** or **▲** to continue to **Test Relay Output**.

Testing functionality of the pressure sensor (**Test pressure sensor**)



This function is only required to calibrate the pressure sensor.

Testing functionality of relay outputs

1. Press **SET** and choose between **Alarm 1, 2, 3, 4** with **▶** or **▲**.

2. Press **SET**.

The relay can now be tested. You can choose between **OFF** and **ON** using **▶** or **▲**. If **ON** is chosen, the NO contact is closed, the NC contact opened. If **OFF** is chosen, the NC contact is closed, the NO contact opened.

3. To test, route a measuring cable from the relay terminals (see Connecting the relay outputs, page 23) out of the transmitter to a multimeter (resistance measurement) or continuity tester.
4. Return to **Test Relay Output** with **SET** (starts relay test) or **ESC** (exits the menu without relay test).

Reading off min./max. values of channels

To reset the max./min. values, see Editing Reset main menu, page 47

1. Read off the min./max. values of the channel in succession with **▶** or **▲** and return to the **Main Menu Analysis** with **ESC**.
2. Continue to **Main Menu Message** with **▶** or **▲** or return to Measuring Mode with **ESC**.

4.4.6.5. Editing Message main menu

Messages can be confirmed/acknowledged, the last messages can be called up and the display of the messages can be switched on or off.

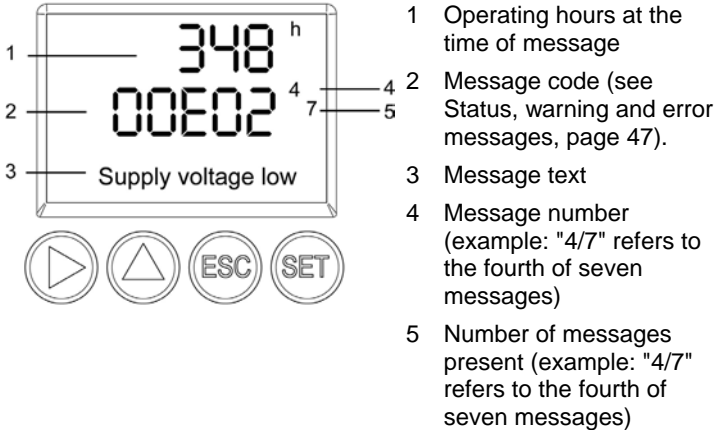

i Using the P2A software (see Parameterizing, adjusting and analyzing software (P2A software), page 53) you can predefine whether messages are to be shown in the display.

1. In the Measuring Mode press **SET**, select **Main Menu Message** with **▶** or **▲** and confirm selection with **SET**.
2. Confirm **Confirm message** using **SET**.
3. Select **Last messages** with **▶** or **▲** and confirm with **SET**.
4. Scroll between the warning and error messages recorded so far using **▶** or **▲** and return to **Last messages** using **ESC**.
5. Select **Information** with **▶** or **▲** and confirm with **SET**.
6. Scroll between the status messages recorded so far using **▶** or **▲** and return to **Information** using **ESC**.
7. Continue to **Display of message** with **▶** or **▲**.
 - ON**: Measurements are shown on the display in Measuring Mode.
 - OFF**: No messages shown on display.
8. Select **ON** or **OFF** with **▶** or **▲** and confirm selection with **SET**.
9. Return to **Main Menu Message** with **ESC**.

10. Continue to **Main Menu Ident** with **▶** or **▲** or return to Measuring Mode with **ESC**.



An overview of the messages can be found in Status, warning and error messages, page 47

4.4.6.6. Calling up Main Menu Ident

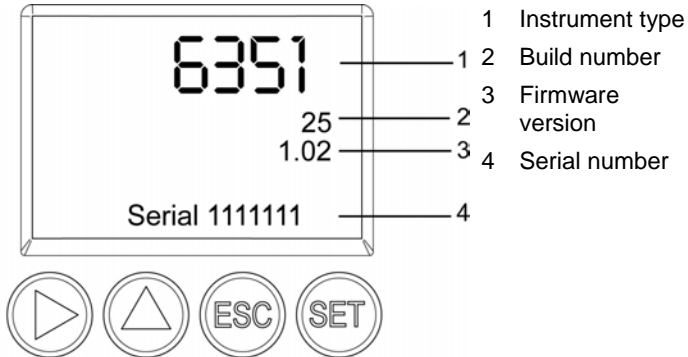

1. In the Measuring Mode press **SET**, select **Main Menu Ident** with **▶** or **▲** and confirm selection with **SET**.
- The type, firmware version, build number and serial number of the transmitter are displayed.



This information is required when servicing.

2. Return to **Main Menu Ident** with **ESC**.
3. Continue to **Main Menu Adjust** with **▶** or **▲** or return to Measuring Mode with **ESC**.

4.4.6.7. Editing Main Menu Adjust

Also see Analog output adjustment, page 29, for instructions on how to perform the analog adjustment.

Performing analog adjustment

1. In the Measuring Mode press **SET**, select main menu **Adjust** with **▶** or **▲** and confirm selection with **SET**.



Each channel is adjusted at three points in the analog range (at 10 %; 50 %; 90% of the analog scale).

2. Select **Analog Adj. Ch. 1** with **▶** or **▲** and confirm with **SET**.
3. Use **▶** or **▲** to select **Adj. Point 1**.

4. Press **SET**. Read off multimeter display and enter this value in the user menu. Do this by scrolling one digit to the right using **▶** and increasing the value of digit by 1 using **▲**. Confirm with **SET** or abort entry with **ESC**.
5. Use **▶** or **▲** to select **Adj. Point 2**.
6. Press **SET**. Read off multimeter display and enter this value in the user menu. Do this by scrolling one digit to the right using **▶** and increasing the value of digit by 1 using **▲**. Confirm with **SET** or abort entry with **ESC**.
7. Use **▶** or **▲** to select **Adj. Point 3**.
8. Press **SET**. Read off multimeter display and enter this value in the user menu. Do this by scrolling one digit to the right using **▶** and increasing the value of digit by 1 using **▲**. Confirm with **SET** or abort entry with **ESC**.
9. Return to main menu **Adjust** with **ESC**.
10. Continue to main menu **Reset** with **▶** or **▲** or return to Measuring Mode with **ESC**.

Performing the pressure adjustment

Also see n-point adjustment, page 30, for instructions on how to perform the pressure adjustment.

1. In the Measuring Mode press **SET**, select main menu **Adjust** with **▶** or **▲** and confirm selection with **SET**.



The pressure adjustment can be performed at 3 to 6 adjustment points.

2. Select **Adjust Pressure** with **▶** or **▲** and confirm with **SET**.
3. Use **▶** or **▲** to select **Adj. Point 1**.
4. Press **SET**. Read off pressure sensor display and enter this value in the user menu. Do this by scrolling one digit to the right using **▶** and increasing the value of digit by 1 using **▲**. Confirm with **SET** or abort entry with **ESC**.
5. Repeat steps 1 to 4 for adjustment points 2 to 6.
6. Return to main menu **Adjust** with **ESC**.
7. Continue to main menu **Reset** with **▶** or **▲** or return to Measuring Mode with **ESC**.

4.4.6.8. Editing Reset main menu

You can reset the factory settings for the following:

- Instrument
- Min./max. values



Resetting to the factory settings means resetting to the order specification, i.e. the specific condition at the time of supply to the customer.

1. In the Measuring Mode press **SET**, select **Main Menu Reset** with **▶** or **▲** and confirm selection with **SET**.
 - **Reset Device** to factory settings is displayed.
2. Select the setting to be reset using **▶** or **▲** and confirm selection with **SET**.
 - **Reset Completed** is displayed.
3. Return to the reset setting with **ESC** or **SET** and return to **Main Menu Reset** with **ESC**.
4. Continue to the **Main Menu Channel 1** with **▶** or **▲** or return to Measuring Mode with **ESC**.

4.5. Status, warning and error messages

To achieve optimum operational reliability (machine availability), the transmitter shows the following via the user menu or the P2A software

- Status messages
- Warning messages
- Error messages

in each case for the testo 6351 transmitter.

All messages are stored in the transmitter with an operating hours stamp. Use the user menu (see Editing Message main menu, page 44) or the P2A software (see Transmitter history, page 75) to view the message history.

In the transmitter, the last 60 status messages and the last 120 error and warning messages are stored in a ring memory. There is no limit in the P2A software.

4.5.1. Status messages

Status messages show the current operating status of the testo 6351.

Message	Display	Description
02506	Sensor initialization	Message appears while the transmitter is starting up. If the message disappears, the transmitter is ready for operation.
01D19	Service plug	The Mini-DIN socket is connected to: the USB adapter for P2A software, the adjustment adapter or the service plug (is not recorded/no number)
00300	New limit value	The limit value has been changed or shifted
00301	Scaling changed	The scaling has been changed
00117	Adjustment DeltaP	An n-point adjustment was performed.
02104	Analog adjustment	An analog adjustment has been made
00530	Change solenoid valve	The solenoid valve should be changed
00500	Transmitter reset	The transmitter was reset to the factory settings and is restarted.
0052F	Reset Min/Max	Resets all saved Min/Max values for all channels
00503	Reset device to fact	A factory reset of the transmitter was performed
00307	User Setting Change	User Setting Change: General settings were changed for the transmitter.

4.5.2. Warning messages

Warning messages show an early warning or a current malfunction which may negatively impact measuring.

Message	Display	Cause	Remedying of fault
00E00	T ambient high	The ambient temperature exceeds the permissible temperature for the transmitter	Take necessary measures to lower ambient temperature, e.g. through venting or cooling
00E01	T ambient low	The ambient temperature is below the permissible temperature for the transmitter	Take necessary measures to raise ambient temperature, e.g. through heating
00809	Pressure too high	The process pressure exceeds the pressure intended for the transmitter	Remove the transmitter from the process and take any necessary measures to lower the pressure
00E02/00E05	Supply voltage low	The supply voltage is below the minimum voltage required for the transmitter	Take measures to ensure sufficient voltage supply
0081C	Alarm 1	Depending on the parameterization of the relay	Depending on the parameterization of the relay
0081D	Alarm 2	Depending on the parameterization of the relay	Depending on the parameterization of the relay
0081E	Alarm 3	Depending on the parameterization of the relay	Depending on the parameterization of the relay
0081F	Alarm 4	Depending on the parameterization of the relay	Depending on the parameterization of the relay

4.5.3. Transmitter error messages

Error messages show a current malfunction.

Message	Display	Cause	Remedying of fault
01505	Watchdog error	Due to a processor error, the transmitter performs an automatic restart.	If the problem occurs frequently, contact Testo Service.
01115	Low adjustment temperature	The ambient temperature is too low during the pressure adjustment.	Take necessary measures to raise ambient temperature, e.g. through heating.
01116	High adjustment temperature	The ambient temperature is too high during the pressure adjustment.	Take necessary measures to lower ambient temperature, e.g. through venting.

4.5.4. Handling alarm messages

Shown on the display ⁵	Can be used for collective alarm ⁶	Additional message end ⁷
New limit value	x	
Scaling changed	x	
Adjustment DeltaP	x	
Pressure too high	x	x
Alarm 1		x
Alarm 2		x

⁵ If multiple messages/alarms are activated at the same time, only the last message/alarm is shown. If this is cancelled, the other messages that are still active are no longer displayed.

⁶ The message can be assigned the collective alarm function, which means that the collective alarm is activated as soon as at least one of the messages assigned to it is activated. The collective alarm can be assigned to each of the 4 optional relays. The collective alarm is then always the same, as it can only be defined once.

⁷ The message is shown upon the occurrence of the event causing the message as well as when closing. Two entries appear in the history in the P2A software: Message text_start and Message text_end.

Shown on the display ⁵	Can be used for collective alarm ⁶	Additional message end ⁷
Alarm 3		x
Alarm 4		x
Transmitter reset	x	
Analog adjustment	x	
T ambient high	x	x
T ambient low	x	x
Supply voltage low	x	x
Watchdog error	x	

Perform the **Confirm message** function (acknowledgement of the alarm via the control keys on the transmitter):

- The message/alarm is no longer shown on the display and the optical alarm goes out, where applicable. If multiple messages/alerts are active at the same time, all are reset simultaneously.
- If at least one message is assigned to the collective alarm, the collective alarm is reset. If the collective alarm is set on a relay, the relay is also reset, meaning switched to its neutral position.

4.5.5. Namur fault conditions

If the faults named in the following table occur, the analog outputs output special values that enable a general fault warning in the higher-level control system. The values correspond to the "Namur" industry standard.

Status message in the display	Class	Display value in the display	Analog output				
			0 to 20 mA	4 to 20 mA	1 V	5 V	10 V
Watchdog error	Error	Previous value stops	21 mA	3.8 mA	1.1 V	5.5 V	11 V
Value below min. scale	Underrange	Reading	0 mA	3.8 mA	0 V	0 V	0 V
Value above max. scale	Overrange	Reading	20.5 mA	20.5 mA	1.1 V	5.5 V	11 V

Status message in the display	Class	Display value in the display	Analog output				
Pressure too high	Overrange	00000 ·	20.5 mA	20.5 mA	1.1 V	5.5 V	11 V

4.6. Maintenance and cleaning

4.6.1. Maintaining the instrument

We recommend that the adjustment and settings of the transmitter be checked at regular intervals using the

- User menu (Operation, page 31) or
- P2A software (Parameterizing, adjusting and analyzing software (P2A software), page 53)

Convenient "remote monitoring" of the transmitter can be implemented, for example by using a relay as a collective alarm (see Editing Main Menu Alarm, page 37) whose messages are forwarded to a local alarm transmitter (horn, light) or PLC.

4.6.2. Cleaning the instrument

- Only clean the instrument carefully with a moist cloth.
- Do not use aggressive cleaning agents.
- Do not use any solvents.

5 Parameterizing, adjusting and analyzing software (P2A software)

5.1. Specifications

The P2A software is used for the parameterizing, adjustment and analysis of testo transmitters. The following applies:

- Generally, all newer testo transmitters (as of 2007) are supported.
- Included with every testo transmitter that is bought new is a CD that contains a free upgrade of the software, which includes the device drivers for all transmitters that can be attached at this time.
- This upgrade can be downloaded at any time via the testo homepage "www.testo.com/Download/P2A".

The software must only be bought one time, even for owners of several testo transmitters.

5.1.1. Functions and use

In the P2A software, two different file types are used: The instrument and the parameter file.

Instrument file

The parameters of a particular transmitter are stored in its so-called instrument file. Using this file, the parameters can be edited and the instrument can be tested and adjusted.

Instrument files also contain the respective histories in addition to the parameter data, i.e. "log books" are kept for the previous parameterizations, adjustments and messages (see Transmitter history page 75).



Instrument files are ".cfm" format files.

Parameter file

Parameter files are not tied to a specific individual transmitter and contain only parameter data/no history data.

If you use various instruments of the same type, you can create parameter files once (e.g. by saving the appropriate instrument file as the parameter file) and transmit these onto the other instruments.



Parameter files are ".cfp" format files.

5.1.2. System requirements

Operating system

- Windows® 2000 SP4
- Windows® XP Home/Professional
- Windows® Vista

Computer

- Pentium processor of at least 400 MHz or equivalent
- 128 MB RAM
- Graphics resolution of at least 1024 x 768
- Unused hard drive capacity of at least 15 MB
- CD-ROM drive
- USB interface
- At least Internet Explorer 5.0.

Software

The P2A software must be purchased and installed separately from the transmitter. If it is a new software version, the transmitter is already supported completely. Older P2A software versions can be updated via the P2A software upgrade (cf. product CD included with the transmitter).

5.1.3. Scope of delivery

Included in the scope of delivery are:

- P2A software
- USB driver



When working with the parameterizing, adjusting and analyzing software (P2A software), previous knowledge of Windows® operating systems is assumed. The description in this instruction manual relates to Windows® XP.

5.2. First steps

5.2.1. Installing the software/driver

i Administrator rights are required to install programs and drivers under Windows® 2000 SP4, XP and Vista.

5.2.1.1. Installing P2A software

1. Insert CD with P2A software.
 - ✓ If the installation program does not start automatically:
 - > Open Windows Explorer and start the file **Setup.exe** on the product CD.
2. Follow the directions of the installation wizard.

5.2.1.2. Installing USB driver

i Before installing the USB driver, please read the separate documentation that is enclosed with the USB driver CD.

5.2.1.3. P2A software upgrade

1. Insert product CD (supplied with the transmitter).
2. Open Windows® Explorer and start the file **P2A upgrade.exe** on the product CD.
3. Follow the directions of the installation wizard.

5.2.2. Starting the software

5.2.2.1. Starting the program

- > Select: **[Start] > All Programs > Testo > P2A Software.**
- The program window is opened (see User interface page 56).

5.2.2.2. Establishing a connection with the instrument

Multiple instruments can be attached, however only one connection is active at all times.

- ✓ USB driver is installed (see Installing USB driver page 55).
1. Start the P2A software.
 2. Connect adapter (supplied with the P2A software) to the service interface of the instrument (see Service interface page 15).

3. Connect instrument/adaptor to the PC via the USB interface.
 - The instrument file of the attached instrument is shown in the file list.

5.2.2.3. Activating the connection with the instrument

- > Click on the desired instrument file.
 - The selected file is marked in colour and the connection with the instrument is activated.

If a connection with the instrument is established when the program is started, the corresponding instrument file is marked automatically.

5.3. Using the software

5.3.1. User interface

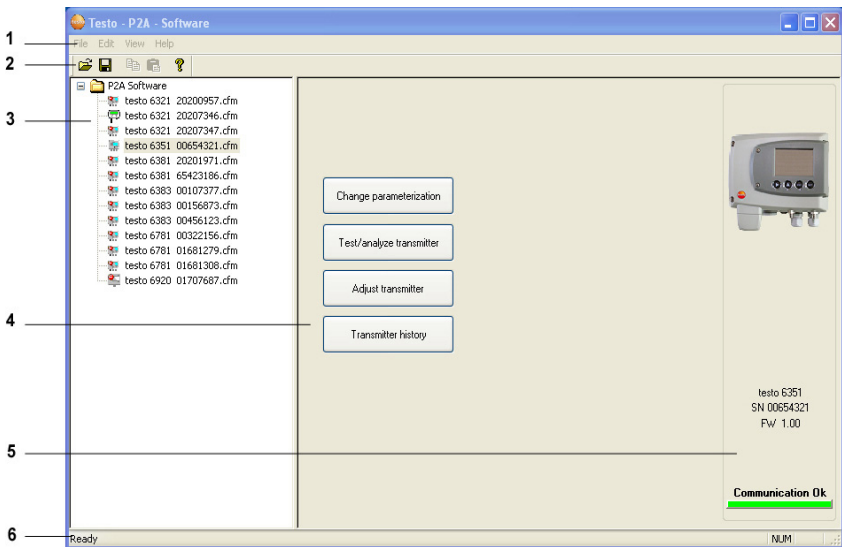



1 Menu bar:

Menu	Command	Explanation
File	Open	Shows the Windows dialogue for searching and opening files.

Menu	Command	Explanation
	Save as	Saves the parameters of an instrument or parameter file under a new name.
Edit	Copy	Copies the parameters of the marked instrument or parameter file in the cache.
	Paste	Pastes the parameters from the cache in the marked instrument or parameter file.
View	Toolbar Status bar	Activates/deactivates the toolbar or status bar.
?	Check instrument connections	Checks the connections to a connected instrument without the instrument having to be activated.
	Service	A text file with the most important information on the computer and the software is opened via Display service data .
	Information	Shows the version number of the P2A software.

2 Toolbar: Shows the Windows-compliant icons for editing.

3 File:

Icon	File	Explanation
 Symbol shows a transmitter	Instrument file	Instrument file Connection to the instrument has been established. <Type> <Serial number>.cfm File name should not be changed.
 Symbol shows a transmitter with a red minus sign in the upper left corner	Instrument file	Instrument file Connection to the instrument has not been established.

Icon	File	Explanation
 <p>Symbol shows a transmitter with a white P for parameter file in the upper left corner</p>	Parameter file	<p><Type> <Serial number> <Date> <Time>.cfp</p> <p>File name can be changed.</p> <p>The name can be selected freely, but it is recommended that you retain the reference to the instrument.</p> <p>Parameter files are always marked red; the parameter values they contain are only forwarded to the instrument after being transmitted to the instrument file.</p>

4 Function buttons: Dialogues on editing and testing the instrument are opened by means of the buttons.

[Change parameterization] see Changing instrument/parameter file page 59

[Test/analyze transmitter] see Chapter Analyzing/testing the transmitter page 68

[Adjusting the transmitter] see Chapter Adjusting the transmitter page 73

[Transmitter history] see Transmitter history page 75

5 File information:

Status	Shown in the window
An instrument file is selected	Type, serial number, firmware version of the instrument.
A parameter file is selected	Type, serial number and firmware version of instrument for which the parameter file was created.
Connection status	Green = connection is active Red = connection is inactive

6 Status bar: Shows the current status when editing via the menu bar.

5.3.2. Editing instrument/parameter file

5.3.2.1. Changing instrument/parameter file

- ✓ The desired instrument/parameter file is marked.
- 1. Click on **[Change parameterization]**.
 - The **Properties of <Instrument type> <Serial number>** dialogue is opened with the **Change parameterization** register.

If the parameters were transmitted from other parameter files into the instrument file, a message is shown with which you can transmit the new parameters to the connected instrument using **[Yes]**.

> If the parameters should not be transmitted, click on **[No]**.

2. Change or enter parameters in the corresponding fields.

Field	Explanation
Unit/ Analog output	All analog outputs are parameterized in this mask.

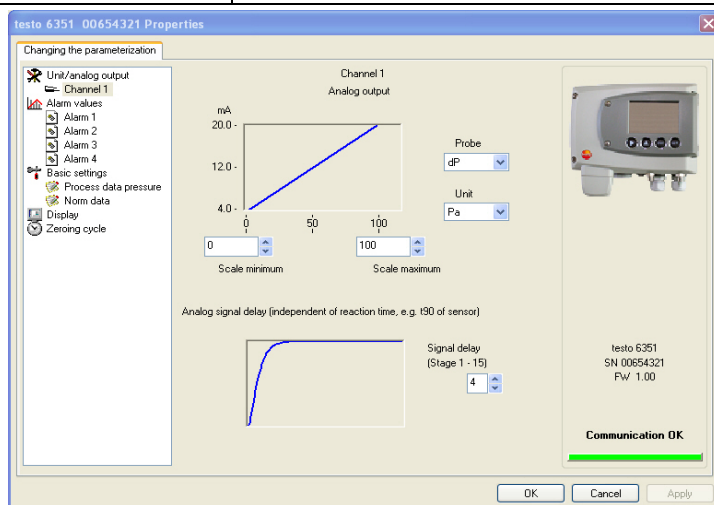

Field	Explanation
Unit/analog output (graphic)	<p>Unit: 0 to 1 V/5 V/10 V or 0 to 20 mA/4 to 20 mA.</p> <p>Vertical: Current version of the analog output (cannot be changed).</p> <p>Horizontal: Min./max. scale end points of selected unit.</p> <p>The curve changes in accordance with the entered value of scale minimum and maximum.</p>
Scale minimum/maximum	<p>The endpoints of the scaling can be selected up to the stored scale minimum and maximum. In the process, scaling can take place beyond the measuring range in order to adjust the analog output to the customer system, see Scaling, page 16</p>
Unit	<p>Selection of the physical unit.</p> <p>When changing the unit, standard values are set for scale minimum and maximum.</p> <p>Caution!</p> <p>When changing the phys. unit, the relay limit values are set to the assigned default values.</p>
Signal delay (graphic)	<p>Curve changes according to the set signal delay.</p>
Signal delay	<p>Time interval in stages 1 – 15:</p> <p>1 = no delay</p> <p>15 = longest delay.</p> <p>The signal delay is added to the reaction time of the sensor. The signal delay shows averaging over the time interval of the selected stage in seconds:</p> <p>Example</p> <p>Stage 10 = average of the readings from the last 10 seconds.</p>

Field	Explanation
Limit values, relay 1 to 4/alarm values, alarm 1 to 4	In this mask, the relays or display alarms are parameterized.

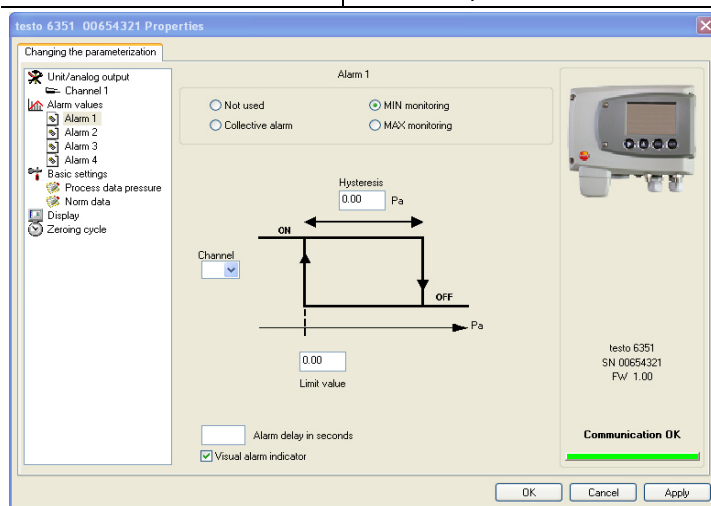

Relay x/alarm x	Four relays or alarm values are available (optional).
Not used	Relay is not used. Hysteresis image and input options are hidden.
Collective alarm	A relay can be used as a collective alarm detector in the event that selected messages appear. Selection of the messages (OR linkage) by selecting the checkbox.
Min control	If switched to ON (NO contact) or OFF (NC contact) under the limit value; in the event of a subsequent exceeding of Limit value plus Hysteresis , it is switched to OFF (NO contact) or ON (NC contact).

Field	Explanation
Max control	If switched to ON (NO contact) or OFF (NC contact) above the limit value; in the event of a subsequent undershooting of Limit value minus Hysteresis , it is switched to OFF (NO contact) or ON (NC contact).

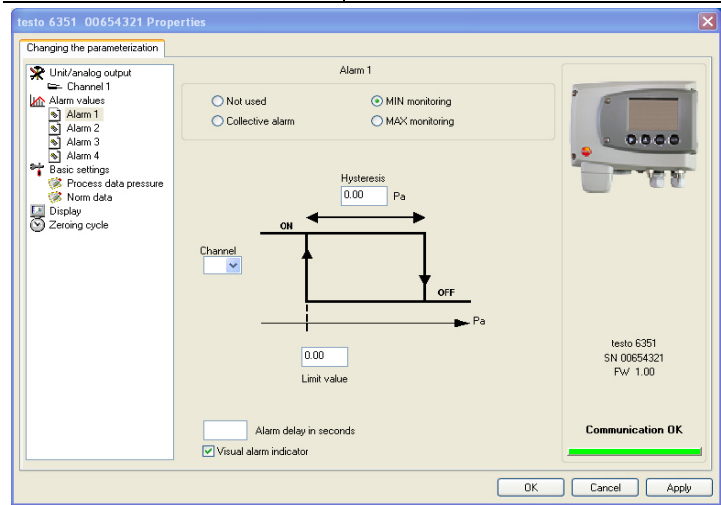

i The graphic display in the centre of the screen refers to the relay wiring as a NO contact (ON).

Hysteresis	To avoid switching cycles.
Channel	Selection of the channel that is to be monitored.
Limit value	Values for the limits of the unit selected in Unit/analog output ; 4 decimal places. When changing the phys. unit, the relay limit values are set to the default values.
Visual alarm display	Checkbox is activated: Upon the appearance of the selected alarm, the background lighting of the display flashes.

Field	Explanation
Alarm delay	The desired alarm delay for the alarms of the min/max control and the visual alarm is entered in the input field (0 to 240 seconds possible). The alarm delay has no effect on the collective alarms.

Field	Explanation
Basic settings	Setting the pressure process data for Pitot tube measurement and standard data for volumetric flow rate measurement.

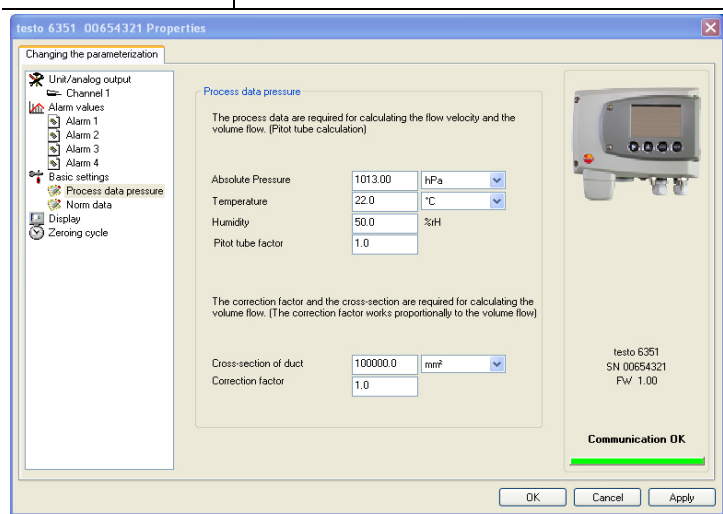

Absolute pressure	Absolute pressure existing in the process. The entered absolute pressure value is included in the Pitot tube calculation.
Temperature	Temperature existing in the process. The entered temperature value is included in the Pitot tube calculation.
Humidity	Humidity existing in the process. The entered humidity value is included in the Pitot tube calculation.

Field	Explanation
Pitot tube factor	The Pitot tube correction factor depends on the shape of the Pitot tube (see operating instructions of the Pitot tube). The entered correction factor has a direct proportional effect on the volumetric flow rate.
Cross-section of the duct	The entered value is included in the Pitot tube calculation.
Correction factor	The correction factor enables an adjustment to the flow profile in the duct. The entered correction factor is included in the Pitot tube calculation.

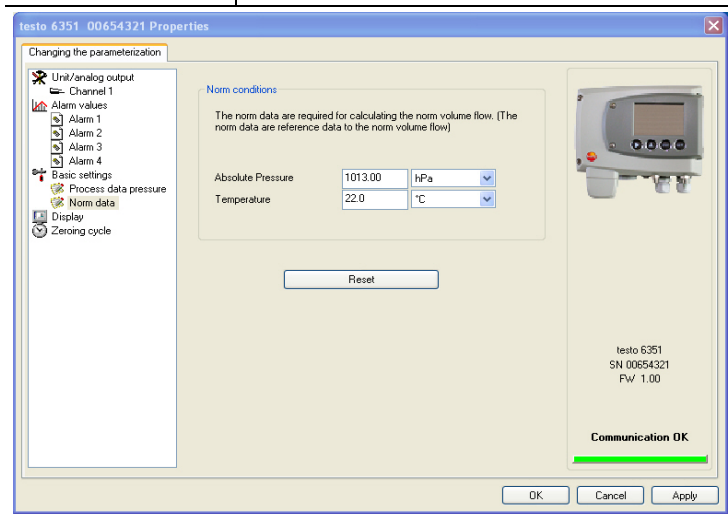

Absolute pressure	The entered value and the selected unit are included in the calculation of the standard volumetric flow rate.
Temperature	The entered value and the selected unit are included in the calculation of the standard volumetric flow rate.
[Reset]	Button for resetting the standard data to the factory settings.

Field	Explanation
Display	Setting the display functions (if a display is available on the transmitter).

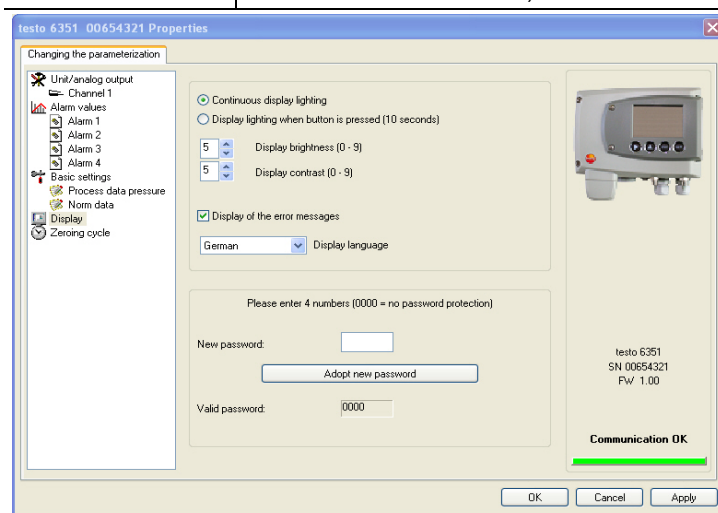

Continuous display lighting	Display lighting is permanently switched on.
Display lighting when button is pressed (10 seconds)	When a particular button on the instrument is pressed, the display lights up for 10 seconds.
Display brightness (0 to 9)	Setting the brightness between 0 and 9: 0 = dark 9 = light
Display contrast (0 to 9)	Setting the contrast between 0 and 9: 0 = low contrast 9 = high contrast
Display of the error messages	Selection of whether the error messages should be shown in the display.
Display language	Selection of the language.
New password	The password consists of four numbers, each of which must be between 1 and 9. If the password protection is not to be used, the numerical code "0000" must be entered.

Field	Explanation
[Adopt new password]	Button for confirming the new password.
Valid password	Display of the current password.

Field	Explanation
Zeroing cycle	Setting the interval of the automatic zeroing with solenoid valve.

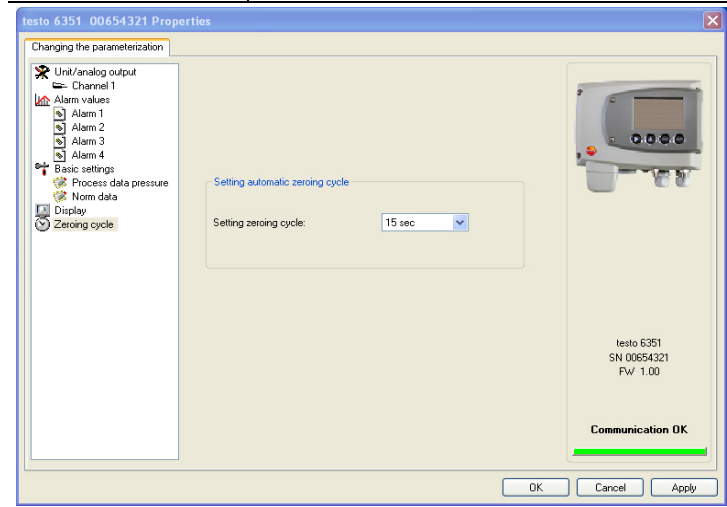

i The accuracy specifications are only valid for the zeroing cycle of 15 sec set by the factory.

Zeroing cycle setting	Selection of the time interval after which the automatic zeroing cycle is to occur. Recommendation: 15 sec
-----------------------	---

5.3.2.2. Saving parameters

Parameters can be saved in new parameter files.

1. Mark instrument/parameter file.
 2. Click on **File > Save as** in the menu bar.
 3. Select storage location and enter the file name.
 4. Click on **[Save]**.
- The new parameter file is shown in the file list.

Only the parameters are saved from an instrument file; the history data are not adopted.



The original name (Instrument type, Serial number) is suggested with the current date/time as standard, e.g. "testo 6351 01234578 061120 1403.cfp".

For a standard installation, the files are saved under "C:\Documents and Settings\All Users\Shared Documents\P2A Software". The path can differ depending on the version of the operating system.

5.3.2.3. Opening the parameter file

All parameter files stored in the standard directory path are automatically displayed in the file list when the software is started.

You can also open parameter files that are stored in other directories.

1. Click on **File > Open** in the menu bar.
2. Select the storage location and click on the requisite file.
3. Click on **[Open]**.
- The selected file is opened. This can be changed and saved (see Editing instrument/parameter file page 59).

5.3.2.4. Copying and pasting parameters

The parameters of a parameter file can be transmitted to an instrument file or another parameter file from the same instrument type.

1. Select file from which parameters are to be copied.
2. Click on **Edit > Copy** in the menu bar.
3. Select the file which is to be modified.
4. Click on **Edit > Paste** in the menu bar.
- The parameters are transmitted to the file.



You can also use the common keyboard shortcuts for copying (CTRL+C) and pasting (CTRL+V).

Parameters can also be transmitted using drag & drop, where you drag the icon of the parameter file onto the icon of the target instrument file.

5. Connect and select corresponding instrument.
6. Click on **[Change parameterization]**.
7. Confirm confirmation request.

- Parameter data are transferred to the instrument.

5.3.2.5. Deleting instrument/parameter file

Instrument/parameter files can be deleted from the file list.

1. Click on the file that is to be deleted with the right mouse button.
 2. Select the command **Delete** in the context menu.
- The instrument or parameter file is deleted from the list.

5.3.2.6. Creating a new instrument file

It is possible to create an instrument file without restarting the P2A software.

- ✓ Transmitter must be connected.
1. Click on **File > New connection** in the menu bar.
- Connection to the transmitter is established.

5.3.3. Analyzing/testing the transmitter

In this section, you can test the outputs of the connected instrument, read off the limit values and reset the parameters to the factory settings.

The function is only available for instrument files.

5.3.3.1. Analyzing/testing the instrument

- ✓ The required instrument file is marked.
1. Click on **[Test/analyze transmitter]**.
- The **Properties of <Instrument type> <Serial number>** dialogue is opened with the **Test/analyze transmitter** register.
2. Perform action:

Action	Explanation
Carrying out factory reset	Reset the unit, limit value and hysteresis parameters to factory settings (see below).
Testing analog output	Test channel 1 (see Testing functionality of analog outputs, page 42).
Test switch outputs	Manually switch relays 1 to 4 to test for proper function (see Testing functionality of relay outputs, page 43).

Action	Explanation
Display min./max. values	Overview of the minimum and maximum values measured since the last reset of the transmitter (see Displaying min./max. values, page 72).

- Click on **[OK]** or **[Cancel]** to close the dialogue.

5.3.3.2. Carrying out factory reset

- ✓ The required instrument file is marked.
- 1. Click on **[Test/analyze transmitter]**.
 - The **Properties of <Instrument type> <Serial number>** dialogue is opened with the **Test/analyze transmitter** register.
- 2. Mark transmitter test.
 - Current operating hours are shown.
- 3. Confirm control query to perform the reset.
 - The values are reset to the customer-specific factory settings.
- 4. Click on **[OK]** or **[Cancel]** to close the dialogue.

5.3.3.3. Testing analog output

- ✓ The required instrument file is marked.
- 1. Click on **[Test/analyze transmitter]**.
 - The **Properties of <Instrument type> <Serial number>** dialogue is opened with the **Test/analyze transmitter** register.
- 2. Mark channel and test values.

Field/button	Explanation
Transmitter test	Check the analog outputs (see Testing functionality of analog outputs, page 42).

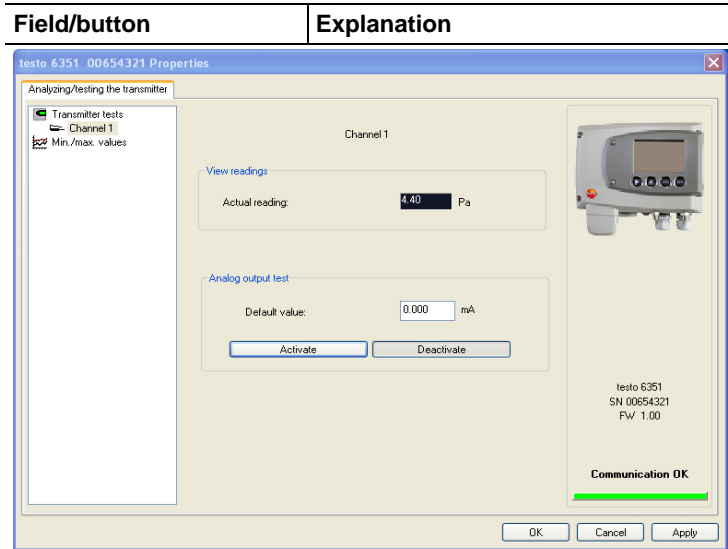

3. Click on **[OK]** or **[Cancel]** to close the dialogue.

- The analog output and the relay return to Measuring Mode again.

5.3.3.4. Testing switch output relays 1 to 4

- ✓ The required instrument file is marked.
- 1. Click on **[Test/analyze transmitter]**.
 - The **Properties of <Instrument type> <Serial number>** dialogue is opened with the **Test/analyze transmitter** register.
- 2. Mark **Relay tests** and test the values.

Field/button	Explanation
	Test the relay function (see Testing functionality of relay outputs, page 43).

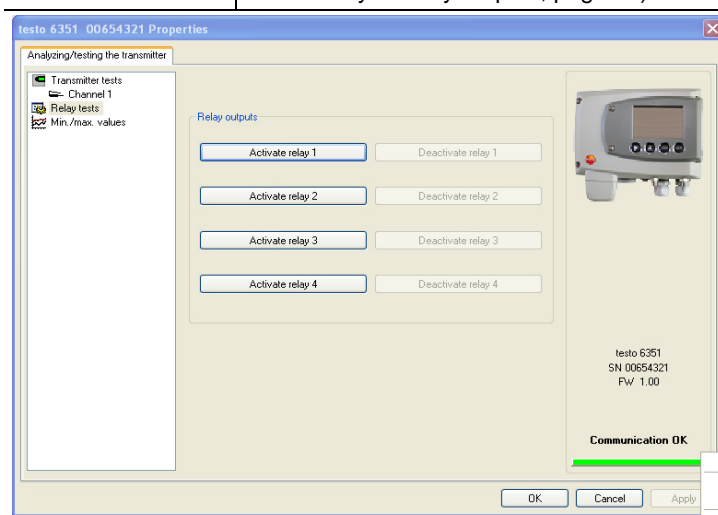

[Activate relay n]	<p>Close contact.</p> <p>A warning informs that the value is being transmitted to a connected PLC, external display, etc. in the event of existing cabling.</p>
[Deactivate relay n]	<p>Open contact.</p> <p>A warning informs that the value is being transmitted to a connected PLC, external display, etc. in the event of existing cabling.</p>

- 3. Click on **[OK]** or **[Cancel]** to close the dialogue.
 - The analog output returns to Measuring Mode again.

5.3.3.5. Displaying min./max. values

The transmitter saves the minimum or maximum value for each channel (measured since the last voltage supply or since the last manual reset).

✓ The required instrument file is marked.

1. Click on [Test/analyze transmitter].
 - The **Properties of <Instrument type> <Serial number>** dialogue is opened with the **Test/analyze transmitter** register.
2. Mark **Min./max. values**.

Field/button	Explanation
Min./max. values	View the min./max. values of each channel. Only the values within the measuring range are shown.

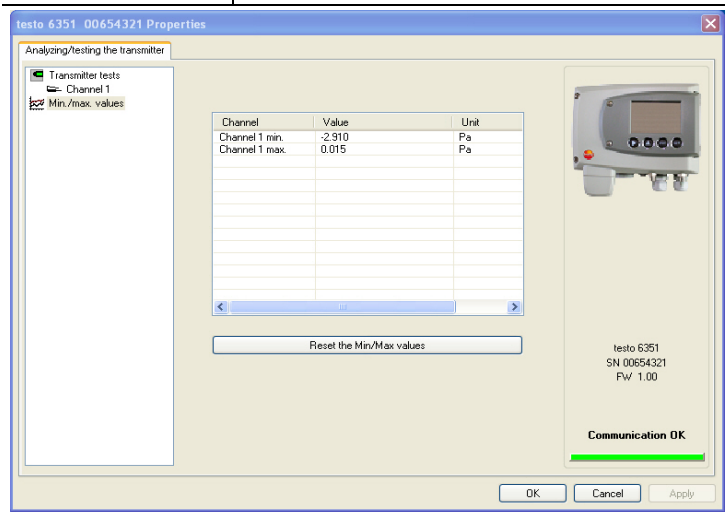

Channel	Channel 1 min./max.
Value	Min. or max. value, 1 decimal place.
Unit	Unit selected in Unit/analog output .

3. Reset **Min./max. values**.
4. Click on [**Reset min./max. values**].
5. Confirm control query to perform the reset.
 - The values are reset to the factory settings.

- Click on **[OK]** or **[Cancel]** to close the dialogue.

5.3.4. Adjusting the transmitter

This function is used to adjust an attached instrument. The following adjustments may be carried out using the software:

- Analog adjustment (entry via assistant/wizard)
- n-point adjustment (entry via assistant/wizard)

Also see Editing Main Menu Adjust, page 45

5.3.4.1. n-point adjustment

- Connect precision pressure sensor (see n-point adjustment, page 30).
- Mark the instrument file of the connected instrument.
- Click on **[Adjusting the transmitter]**.
 - The **Properties of <Instrument type> <Serial number>** dialogue is opened with the **Adjusting the transmitter** register.
- Mark **n-point adjustment**.
- Click on **[Start wizard ...]** and follow the instructions of the wizard.
 - The adjustment is performed when the wizard is closed.

Field	Explanation
-------	-------------

Adjustment characteristics curve

...precise pressure settings required

Adjustment point 1

which value is pre-set by a pressurizer: Pa

< Back Next > Cancel

Field	Explanation
How much pressure is actually applied	Required field: Entry of the value read off at the pressure sensor.
i	The n-point adjustment must always be carried out to its full extent and in good time at all selected adjustment points.
i	The number of adjustment points (3 to 6) is stored in the user menu of the transmitter and can only be changed via the P2A software.

5.3.4.2. Adjusting the analog output

1. Connect precision multimeter (see Analog output adjustment, page 29).
2. Mark the instrument file of the connected instrument.
3. Click on **[Adjusting the transmitter]**.
 - The **Properties of <Instrument type> <Serial number>** dialogue is opened with the **Adjusting the transmitter** register.
4. Click on **[Start wizard ...]** and follow the instructions of the wizard.
 - The adjustment is performed when the wizard is closed.

Field	Explanation

Field	Explanation
Default value	<p>The analog output value from the last performed adjustment is given at the output. Value of the factory adjustment:</p> <ul style="list-style-type: none"> • Lower adjustment point: approx. 10 % of the max. value • Centre adjustment point: approx. 50 % of the max. value • Upper adjustment point: approx. 90 % of the max. value
Measured analog value	Required field: Entry of the value read off at the multimeter.

5.3.5. Transmitter history

Parameterizations, adjustment processes and messages that have occurred are registered in the transmitter with an operating hours stamp.

In the history overviews (explained later in more detail), past processes and events can be made visible.



For parameter changes or adjustments that are performed directly at the instrument (via the user menu), "Transmitter" is entered in the **User** field and only the operating hour is entered in the **Date/time** field instead of operating hour/date/time.

For entries that are performed using the P2A software, the name of the user logged into Windows appears in the **User** field, while the date/time and operating hour are shown in the **Date/time** field.

1. Mark the instrument file of the connected instrument.
2. Click on the **[Transmitter history]** button.
 - The **Properties of <Instrument type> <Serial number>** dialogue is opened with the **Transmitter history** register.
3. Click on the required entry in the list to change the display.

Field	Explanation
Operating hours / date/time	Operating hour/time stamp at which the change at the instrument was performed.
User	Name with which the user is logged into the operating system. "Transmitter" entry if the change was performed at the instrument.
Comments	Type of parameter change, e.g. "Unit of channel 1 from Pa to bar".

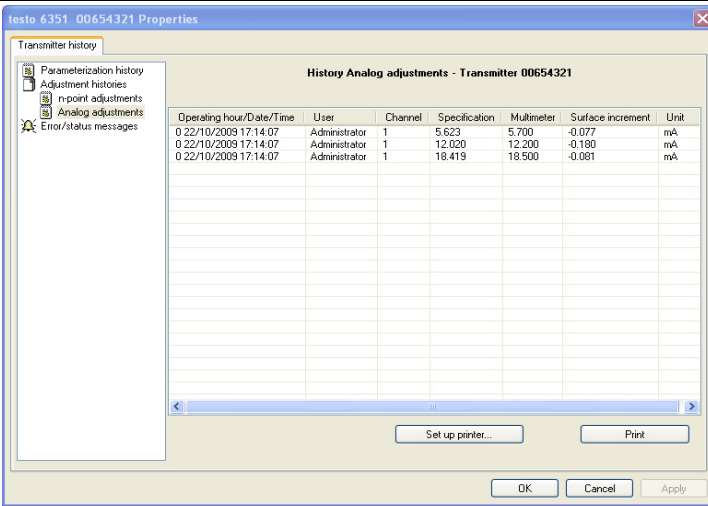
Field	Explanation																												
 <table border="1" data-bbox="420 300 949 592"> <caption>History Analog adjustments - Transmitter 00654321</caption> <thead> <tr> <th>Operating hour/Date/Time</th> <th>User</th> <th>Channel</th> <th>Specification</th> <th>Multimeter</th> <th>Surface increment</th> <th>Unit</th> </tr> </thead> <tbody> <tr> <td>0 22/10/2009 17:14:07</td> <td>Administrator</td> <td>1</td> <td>5.623</td> <td>5.700</td> <td>-0.077</td> <td>mA</td> </tr> <tr> <td>0 22/10/2009 17:14:07</td> <td>Administrator</td> <td>1</td> <td>12.020</td> <td>12.200</td> <td>-0.180</td> <td>mA</td> </tr> <tr> <td>0 22/10/2009 17:14:07</td> <td>Administrator</td> <td>1</td> <td>18.419</td> <td>18.500</td> <td>-0.081</td> <td>mA</td> </tr> </tbody> </table>		Operating hour/Date/Time	User	Channel	Specification	Multimeter	Surface increment	Unit	0 22/10/2009 17:14:07	Administrator	1	5.623	5.700	-0.077	mA	0 22/10/2009 17:14:07	Administrator	1	12.020	12.200	-0.180	mA	0 22/10/2009 17:14:07	Administrator	1	18.419	18.500	-0.081	mA
Operating hour/Date/Time	User	Channel	Specification	Multimeter	Surface increment	Unit																							
0 22/10/2009 17:14:07	Administrator	1	5.623	5.700	-0.077	mA																							
0 22/10/2009 17:14:07	Administrator	1	12.020	12.200	-0.180	mA																							
0 22/10/2009 17:14:07	Administrator	1	18.419	18.500	-0.081	mA																							

Selection: **Analog adjustments.**

Operating hours / date/time	Operating hour/time stamp at which the change at the instrument was performed.
User	Name with which the user is logged into the operating system. "Transmitter" entry if the change was performed at the instrument.
Unit	Unit during the adjustment.
Channel	Analog adjustment: Channel 1 to n.
Specification	Analog adjustment: Actual value.
Pressure specification	n-point adjustment: Reference value set at the pressure sensor.
Multimeter	Analog adjustment: Reference value set at the multimeter.
Offset	Analog adjustment: Deviation at time of adjustment.

Field	Explanation
-------	-------------

The screenshot shows a software window titled 'testo 6351 00654321 Properties'. On the left is a tree view with 'Error/status messages' selected. The main area is titled 'Error/status messages' and contains a table with the following data:

Operating hour	Serialno	Message	Type of message
0	20205671	Init sensor	Status reports
0	20205671	Init sensor	Status reports
0	20205671	Init sensor	Status reports
0	20205671	Init sensor	Status reports
0	00654837	Init sensor	Status reports
0	00654837	Transmitter reset	Status reports
0	00000000	Init sensor	Status reports
0	00000000	Transmitter reset	Status reports
0	00000000	Init sensor	Status reports
0	00000000	Init sensor	Status reports
0	00654321	Init sensor	Status reports
0	00654321	Init sensor	Status reports
0	00654321	Transmitter reset	Status reports
0	00654321	Init sensor	Status reports
0	00000000	Supply voltage low start	Status reports/Early warnings
0	00000000	Supply voltage low start	Status reports/Early warnings
0	00000000	Pressure to high start	Status reports/Early warnings
0	00000000	Supply voltage low start	Status reports/Early warnings
0	00000000	Supply voltage low start	Status reports/Early warnings
0	00000000	Pressure to high start	Status reports/Early warnings
0	00000000	Supply voltage low start	Status reports/Early warnings
0	00654321	Pressure to high start	Status reports/Early warnings
n	00654321	Pressure to high start	Status reports/Early warnings

Buttons at the bottom: Confirm message, Set up printer..., Print, OK, Cancel, Apply.

The table is shown only for error and status messages that were generated in the transmitter and were transferred and saved there via the connection to the P2A software.

Operating hour	Operating hour at which the message appeared in the instrument.
Message	e.g. "Watchdog error". Due to a processor error, the transmitter performs an automatic restart.
Type of message	e.g. early warning, status message.

> To print out the history data, click on **[Print]**.

i The printing job is automatically sent to the default printer for the operating system.

The printout can be edited using **[Set up printer ...]**.

4. Click on **[OK]** or **[Cancel]** to close the dialogue.

6 Tips and assistance

6.1. Questions and answers

Question	Possible causes/solution
Connection to instrument cannot be established	Check connection cable/plug contacts
A message appears on the display	See Status, warning and error messages, page 47
Malfunction (with and without display)	Analysis using the P2A software, see Analyzing/testing the transmitter, page 68
When does a stable current reading appear?	After approx. 20 seconds

If we could not answer your question, please contact your dealer or Testo Customer Service. For contact details see the rear side of this document or the web page www.testo.com/service-contact

6.2. Accessories and spare parts

Description	Article no.
Ethernet	
Ethernet module	0554 6656
Ethernet connector	0554 6653
Interface and software	
P2A software (parameterizing, adjusting, analyzing) incl. USB adapter	0554 6020
Plug-in connections	
Set of M12 plug-in connections (connector and socket) for power and signal lines	0554 6682
Hoses	
Silicone hose ID 4 transparent	0086 0001, sold by the metre
TYGON hose ID 4.8 transparent	0086 0031, sold by the metre

Description	Article no.
Pitot tubes	
Pitot tube, length 350 mm, stainless steel	0635 2145
Pitot tube, length 1000 mm, stainless steel	0635 2345
Supply	
Mains unit (desktop, wall-mounted)	0554 1748
Mains unit (top-hat rail mounting)	0554 1749
External display	
Process display for testo 54-2 AC....	5400 7553
Process display for testo 54-7 AC....	5400 7555
Calibration	
Standard ISO calibration certificate, transmitter only	0520 1000
Standard DKD calibration certificate, transmitter only	0520 1200

For a complete list of all accessories and spare parts, please refer to the product catalogues and brochures or look up our website at: www.testo.com

6.2.1. **Ordering options for testo 6351 transmitter (0555 6351)**

Order code	Characteristic
Axx Measuring range	
A02	0 to 50 Pa
A03	0 to 100 Pa
A04	0 to 500 Pa
A05	0 to 10 hPa
A07	0 to 50 hPa
A08	0 to 100 hPa
A09	0 to 500 hPa
A10	0 to 1000 hPa
A11	0 to 2000 hPa
A22	-50 to 50 Pa

Order code	Characteristic
A23	-100 to 100 Pa
A24	-500 to 500 Pa
A25	-10 to 10 hPa
A27	-50 to 50 hPa
A28	-100 to 100 hPa
A29	-500 to 500 hPa
A30	-1000 to 1000 hPa
A31	-2000 to 2000 hPa
Bxx Analog output/supply	
B02	0 to 1 V (4-wire, 24 V AC/DC)
B03	0 to 5 V (4-wire, 24 V AC/DC)
B04	0 to 10 V (4-wire, 24 V AC/DC)
B05	0 to 20 mA (4-wire, 24 V AC/DC)
B06	4 to 20 mA (4-wire, 24 V AC/DC)
Cxx Display	
C00	Without display
C02	With display/English
C03	With display/German
C04	With display/French
C05	With display/Spanish
C06	With display/Italian
C07	With display/Japanese
C08	With display/Swedish
Dxx Cable entry	
D01	M16 cable entry (relay: M20)
D02	Cable entry NPT 1/2"
D03	Cable contacting via M plug-in connection for signal and supply
Exx Ethernet	
E00	Without Ethernet module
E01	With Ethernet module

Order code	Characteristic
Fxx Differential pressure unit	
F01	Pa/Min/Max
F02	hPa/Min/Max
F03	kPa/Min/Max
F04	mbar/Min/Max
F05	bar/Min/Max
F06	mmH ₂ O /Min/Max
F07	inchH ₂ O /Min/Max
F08	inch HG/Min/Max
F09	kg/cm ² /Min/Max
F10	PSI/Min/Max
F11	m/s /Min/Max
F12	ft/min /Min/Max
F13	m ³ /h /Min/Max
F14	l/min /Min/Max
F15	Nm ³ /h /Min/Max
F16	NI/min /Min/Max
Hxx Relay	
H00	Without relay
H01	4 relay outputs, limit value monitoring
H02	4 relay outputs, channel 1 limit values and collective alarm
Kxx Languages of instruction manual	
K01	German/English instruction manual
K02	French/English instruction manual
K03	Spanish/English instruction manual
K04	Italian/English instruction manual
K05	Dutch/English instruction manual
K06	Japanese/English instruction manual
K07	Chinese/English instruction manual

Order code	Characteristic
K08	Swedish/English instruction manual

