

DETAIL A

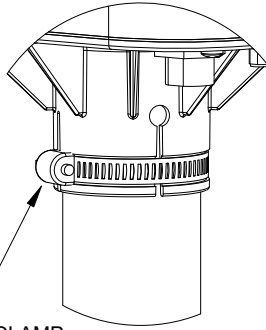

HOSE CLAMP

-ATTACH HOSE CLAMP (SUPPLIED) TO WEATHERHAWK.
-FASTEN TO MOUNTING PIPE.
(CLAMP RANGE OF Ø1.50 -1.66)

REMOVEABLE STICKER
-ALIGN STATION TO THE
NORTHWARD POSITION.
-REMOVE STICKER.

WEATHERHAWK STATION
PLACE ON TOP OF
MOUNTING PIPE OR MAST.

REMOVE ONCE
INSTALLED



18.75"

MOUNTING PIPE
Ø1.66
(1 1/4 METAL PIPE)

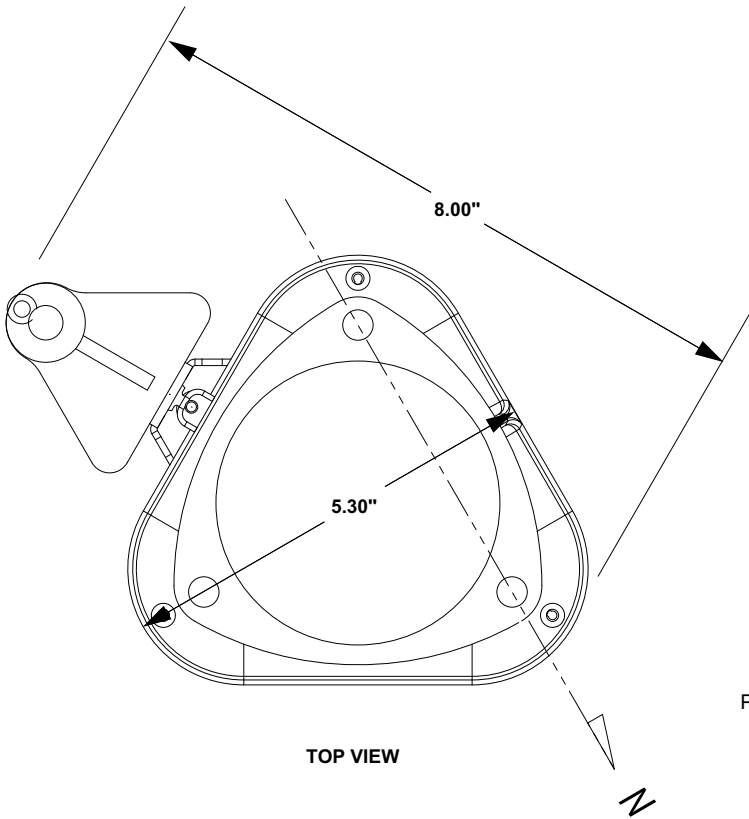

TOP VIEW

SOLAR RADIATION
SENSOR CONNECTOR

ANTENNA
(WIRELESS SYSTEMS ONLY)

POWER SWITCH

EXTERNAL RAIN GAUGE
CONNECTION (OPTIONAL)

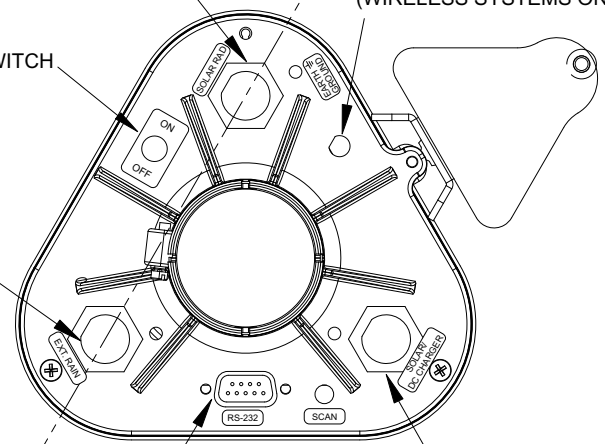

RS-232
CONNECTION

BOTTOM VIEW

INPUT POWER/
SOLAR PANEL

DESCRIPTION:	Installation Details	COPYRIGHT:	05-05-06
MODEL:	WeatherHawk 500 Series	REV.	00